

VRV

Product catalogue 2015
for installers

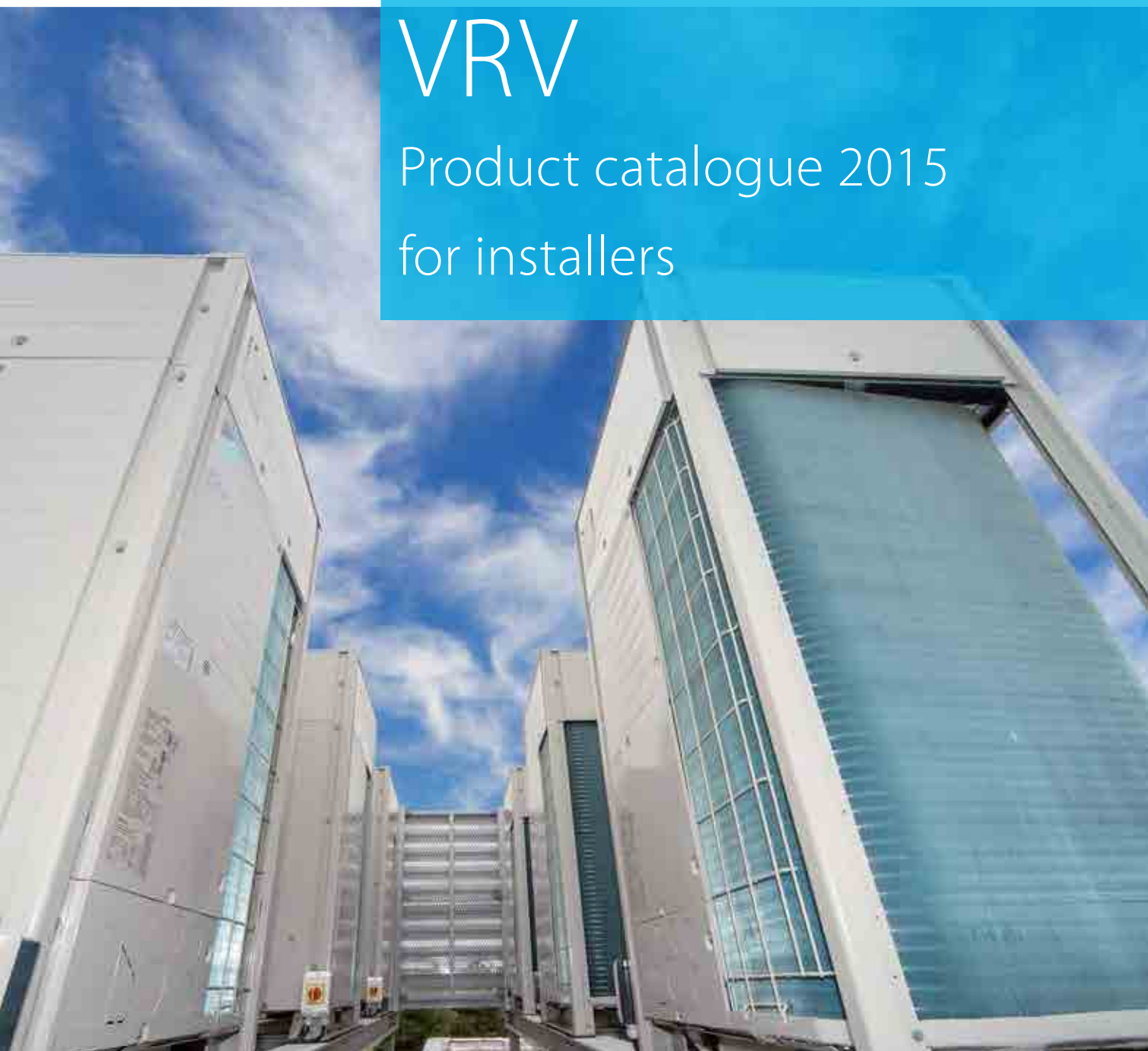

Minimum running costs, maximum flexibility.
Fast installation, top reliability, perfect comfort.



FULLY FLAT CASSETTE
OFFICE APPLICATION



OUTDOOR UNIT



CONCEALED CEILING UNIT
HOTEL APPLICATION



CONCEALED FLOOR STANDING UNIT
RESTAURANT APPLICATION

Table of contents

VRV, the solution for the commercial sector	5	Biddle Air Curtains	176
Daikin VRV systems can be customised to meet the comfort and energy efficiency requirements of any commercial building.		Quick and easy to install, Biddle air curtains are extremely efficient and have a payback time of under 18 months compared to electrical air curtains.	
VRV IV standard & technologies	22	Ventilation and Air Handling	182
Unique and patented technologies that make the difference.		Daikin offers the widest range of ventilation and air handling units for a healthy and comfortable environment.	
Benefits	30	Control Systems	216
Daikin VRV IV systems are quick and simple to customise, commission and service, and they offer the end user perfect reliable comfort and control tailored to their needs.		Daikin's control systems range from building management systems to simple remote controls which are easy to use and offer smart energy management.	
Outdoor unit product range	40	Options and Accessories	238
Daikin outdoor units offer a solution for every application or climate condition.		We offer a full range of options and accessories which allow our systems to be customised to meet different customer requirements.	
Indoor units	100	Literature overview	257
Daikin indoor units are designed to blend in with any décor, from modern to classical, and are silent and comfortable in operation.		Discover all our commercial and technical documentation.	
Hot water	166		
Efficient hot water production for underfloor heating, radiators and air handling units, or for producing hot water for sinks, baths and showers.			

A male technician wearing a white Daikin uniform and a yellow hard hat is standing in a modern building, looking at a laptop. The background shows large windows and a ceiling with recessed lighting.

Why choose Daikin

Our promise is to ensure that **your customers can depend on Daikin for the ultimate in comfort**, so that they are free to **focus on their own working and home lives**.

We promise to dedicate ourselves to **technological excellence**, a **design focus** and the **highest quality standards** so that your customers can trust and rely on the comfort we deliver.

Our promise to the planet is absolute. Our products are at the forefront of **low energy consumption** and we continuously **innovate to reduce the environmental impact** of HVACR solutions further.

We lead where others follow. We will continue our global leadership in HVACR solutions as our specialist expertise in all market sectors combined with **90 years' experience** enable us to **deliver added value in long-lasting relationships based on trust, respect and credibility**.

VRV

The solution for the commercial sector

Daikin's VRV technology leads the way in customisation to match individual commercial building requirements in comfort and energy efficiency. Flexible to cover all applications and climate conditions, VRV has the unique products that make the difference for you and your customers.

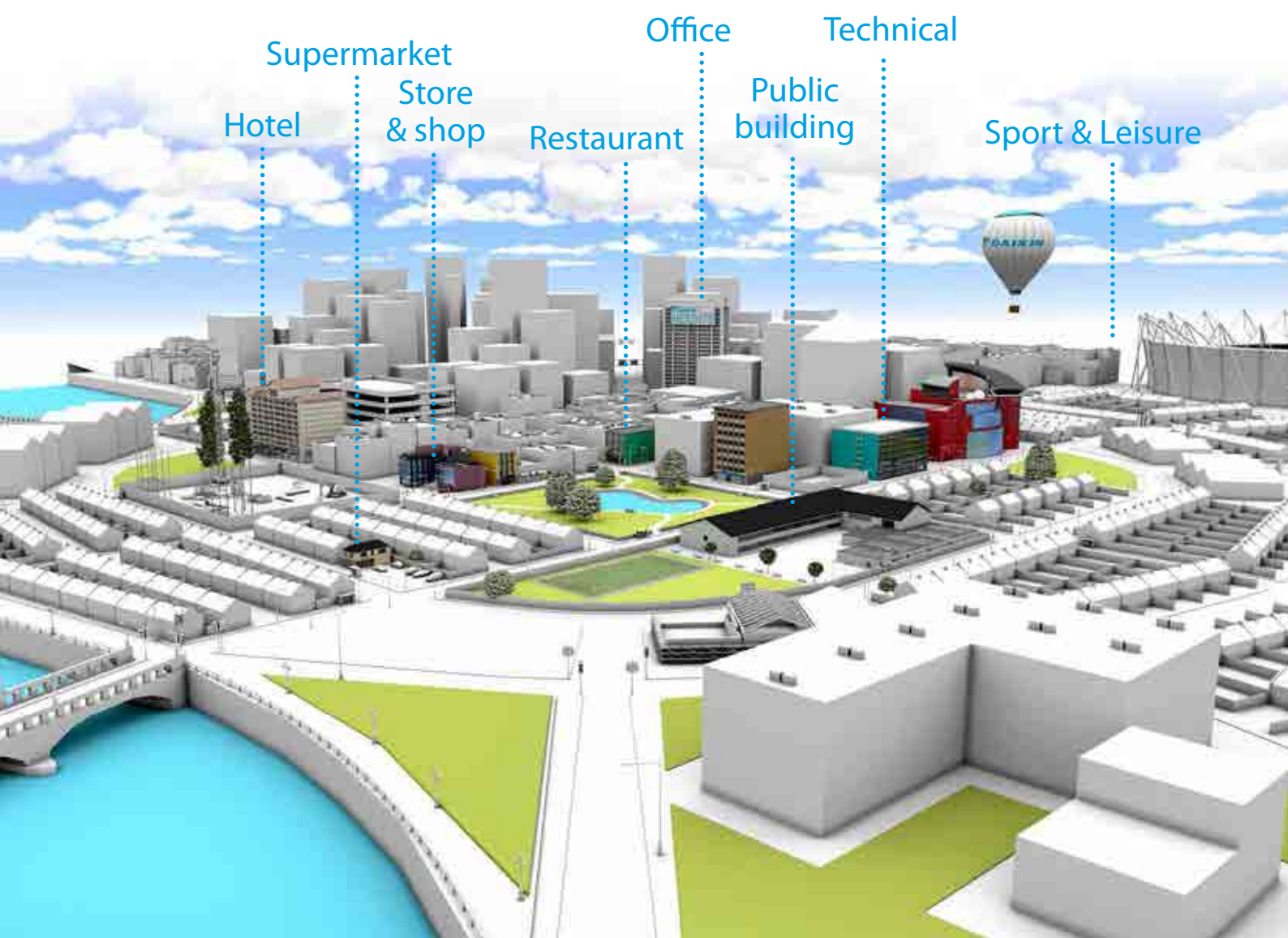

VRV IV sets the standard ... again



Why choose VRV?

- **Inventor and market leader of VRV systems since 1982**

- › Over 90 years of expertise in heat pumps
- › Designed for and produced in Europe

- **Unique outdoor unit range covering all applications and climate conditions**

- **Unique products that make the difference**

in efficiency

- › Variable Refrigerant Temperature leading to the highest seasonal efficiency
- › Round flow cassette with auto cleaning panel

in comfort

- › Variable Refrigerant Temperature preventing cold draughts
- › True continuous heating, during defrost
- › 15 class units for small, well insulated rooms (cassette, wall, concealed ceiling models)
- › Low sound indoor and outdoor units

in design

- › Fully flat cassette, fully integrated in the ceiling
- › Daikin Emura, unique iconic design

in installation

- › Automatic refrigerant charge and refrigerant containment check
- › 4-way blow ceiling suspended cassette (FXUQ)
- › plug & play Daikin air handling unit
- › Total solution incl. low and high temperature hydro box, Biddle air curtains, etc.

in control

- › Intelligent Touch manager cost-effective mini BMS integrating all pillars
- › Easy integrating in third party BMS
- › Dedicated control solutions for applications such as technical cooling, shops, hotels, ...

- **Top reliability**

- › True technical cooling
- › Gas-cooled PCB
- › Most extensive testing before new units leave the factory (copy!)
- › Widest support network and after sales service
- › All spare parts available in Europe

The VRV air conditioning system is the world's first individual air conditioning system with variable refrigerant flow control and was commercialised by Daikin in 1982. VRV is the trademark of Daikin Industries Ltd, which is derived from the technology we call "variable refrigerant volume".



VRV IV standards

• Variable refrigerant temperature

- › Customize your VRV for best seasonal efficiency & comfort
- › Up to 28% higher seasonal efficiency (ESEER)
- › First weather dependent VRV
- › No more cold draft by supply of high outblow temperatures

• Continuous comfort

- › True/real continuous heating makes VRV IV the best alternative to traditional heating systems

• VRV configurator

- › software for the fastest and most accurate commissioning, configuration and customisation

• Total solution

- › one supplier for heating, cooling, ventilation, hot water, Biddle air curtains and control
- › combine both residential and VRV indoor units

• Free combination of outdoor units to meet installation space or efficiency requirements

• Outdoor unit display for quick on-site settings



Heat pump
Heat recovery
Replacement
Water cooled



Benefits for installers

Daikin VRV IV sets the standard with latest technology and time saving commissioning & servicing

- › Simplified and time saving commissioning with VRV configurator
 - › Remote refrigerant containment check
 - › One supplier = one point of contact
- Many options to meet customer requirements

Benefits for consultants

Daikin's VRV IV technology leads the way in customisation to match individual building requirements in comfort and energy, facilitating reduced capital and running costs

- › Ecological design
- › Ideal for reaching top BREEAM/EPDB levels
- › No more cold draughts with higher evaporation temperatures up to 11 or 16°C, making VRV IV an ideal alternative to water-based systems
- › Unique specification for monovalent heating

Benefits for owners

VRV IV is the ultimate in customised comfort and intelligent control tailored to your individual needs and to maximise energy efficiency

- › Annual cost savings up to 28% (compared with VRV III)
- › No more cold draughts with variable refrigerant temperature
- › Single point of contact for the design and maintenance of your climate control system
- › Integrated system allows maximum energy efficiency for the end user
- › Multiple systems can be managed in exactly the same way for key accounts

Digital tools

- › Visit the website:
<http://www.daikineurope.com/vrv-iv>
- › Download simulation or selection software: Go to extranet.daikineurope.com > Software downloads > sales supporting apps



Solutions seasonal simulator

With this software tool you can simulate and the seasonal efficiency, the annual power consumption and CO₂ emission for a given climate, load profile (cooling, heating, heat recovery, covalent, bivalent...) and (combination of) system(s). With its intuitive and graphical appealing interface, a simulation can be made in a matter of minutes. The solution basket system enables you to compare

the results of several system configurations. Optionally, a return on investment calculation can be made. The outcome of the simulation can be exported to a printable report. The tool is available both for Windows PC and Tablet (iPad).

Xpress, Quick Quotation tool

Xpress is a software tool that allows creating on the spot quotations for a Daikin VRV system. It provides a result in 6 steps to enable a professional budget quotation:

- › Select indoor units
- › Connect outdoor units to indoor units
- › Automatic generation of piping diagram with joints
- › Automatic generation of wiring diagram
- › Select possible centralised control systems
- › Visualise result in MS Word, MS Excel and AutoCAD



Ventilation Xpress

Selection tool for ventilation devices (VAM, VKM). The selection is based on given supply/extract airflows (including fresh up), and given ESP of the supply/extract ducting:

- › Determines size of electrical heaters
- › Visualization of psychrometric chart
- › Visualization of selected configuration
- › Required field settings mentioned in the report

VRV Pro, Design tool



The VRV Pro selection program is a true VRV design tool. The program enables VRV air conditioning systems to be engineered in a precise and economical way, taking into account the realtime thermal properties of any building. By calculating

annual energy consumptions, it gives the designer the possibility to make accurate selections and **get competitive quotations** for each project. Moreover, it ensures optimum operating cycles and maximum energy efficiency.

Your References

Porta Fira

"This project reinforces Daikin's position as a leader in the air conditioning of large-scale structures, able to provide solutions that stand out not only for their accuracy and reliability, but also for their energy efficiency."



Eiffage Energie & Thermie

"The customer choose Daikin for the user comfort we offer with the VRV IV with continuous heating. Next to that the design aspect was important. Therefore the fully flat cassette in combination with Split wall mounted units were installed. Together with the ease of installation Daikin offered the best solution for the customer."



For more references check:
<http://www.daikineurope.com/references/index.jsp>

The total solution



Typically, many buildings today rely on several separate systems for heating, cooling, air curtain heating and hot water. As a result energy is wasted. To provide a much more efficient alternative, VRV technology has been developed into a total solution managing up to 70% of a buildings energy consumption giving large potential to cost saving.

- › **Heating and cooling** for year round comfort
- › **Hot water** for efficient production of hot water
- › **Underfloor heating /cooling** for efficient space heating/cooling
- › **Ventilation** for high quality environments
- › **Air curtains** for optimum air separation
- › **Controls** for maximum operating efficiency

Combine up to 70% of your building's energy consumption

Average hotel energy consumption

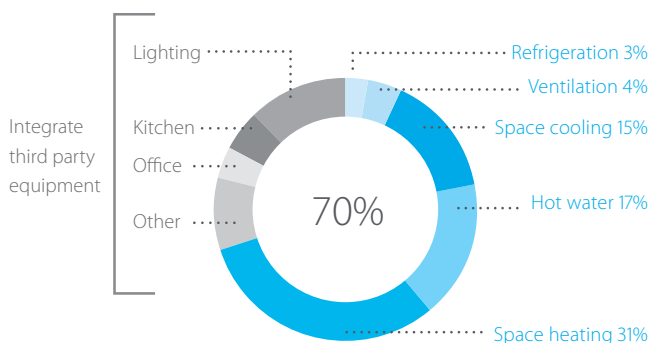

Average office energy consumption

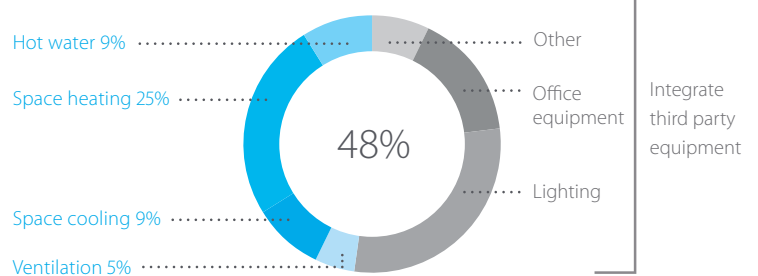

One system,

multiple applications for hotels, offices,
retail, home ...

Heating and cooling



- › Combine VRV indoor units with other stylish indoor units in one system
- › New round flow cassette sets the standard for efficiency and comfort

Intelligent control systems



- › Mini BMS with connects Daikin and third-party equipment
- › Integrate intelligent control solutions with energy management tools to reduce running costs

Low-temperature hydrobox



- › Highly efficient space heating through:
 - Underfloor heating
 - Low temperature radiators
 - Heat pump convector
- › Hot water from 25 °C to 45 °C

Biddle air curtain



- › Payback time less than 1 year compared to electrical air curtain
- › A highly efficient solution for doorway climate separation

High temperature hydrobox*



*only for connection to VRV heat recovery

- › efficient hot water production for:
 - Showers
 - Sinks
 - Tapwater for cleaning
- › Hot water from 25 °C to 80 °C

Ventilation



- › Widest range in DX ventilation – from small heat recovery ventilation to large scale air handling units
- › Provides a fresh, healthy and comfortable environment



VRV for offices and banks

Efficiency in the workplace



Efficient building and facilities management are key to minimising operational costs

Our office solution offers:

- › Significantly reduced costs for hot water and heating by re-using heat recovered from areas requiring cooling
- › Unique fully flat cassette integrating fully flat into architectural ceilings
- › Intelligent sensors
 - maximise efficiency by switching of the unit if there is nobody in the meeting room
 - maximise comfort by directing the air flow from people to avoid cold draught
- › Complete Daikin mini BMS for office building management with Intelligent Touch Manager
- › Plug & play connection to air handling units for a healthier office atmosphere
- › Hot water production for sinks and underfloor heating
- › True reliable technical cooling down to -20°C, including duty/standby function



Check on
YouTube

<https://www.youtube.com/DaikinEurope>



VRV for hotels

Hospitality with economy



A hotel's reputation depends on how welcome and comfortable guests feel during their stay. Yet at the same time, hotel owners must maintain complete control of their operating costs and energy consumption.

Our hotel solution offers:

- › Low cost heating and hot water by recovering heat from areas requiring cooling
- › The perfect personal environment for guests by simultaneously heating spaces while cooling others
- › Flexible installation: the outdoor unit can be installed outdoors to maximise hospitality space or indoors to minimise external space or noise in city centres
- › Concealed ceiling units developed for small, well-insulated rooms such as hotel bedrooms, offering very low sound levels ensuring a good's night rest
- › Smart energy management via Intelligent Touch Manager puts the hotel owner in full control of energy costs
- › Intelligent and user-friendly hotel room controllers change the set point automatically when a guest leaves the room or opens the window
- › Easy integration in hotel booking software
- › Hot water production for bathrooms, underfloor heating and radiators up to 80°C

Check on
YouTube

<https://www.youtube.com/DaikinEurope>





VRV for retail

Reducing retail costs



Retailers are under pressure to reduce both store development costs and running costs. That is why affordable, energy-efficient solutions are vital for minimising lifetime costs, while ensuring compliance with the latest regulations.

Our retail solutions offer:

- › Compact inverter heat pump technology
- › Flexible installation: the outdoor unit can be installed outdoors to maximise hospitality space or indoors to minimise external space or noise in city centres
- › Unique round flow cassettes with autocleaning panel saving up to 50% of energy use compared to standard cassette units
- › Easy to use remote control with lock-key function to avoid improper use
- › Individual control of each indoor unit or shop zone
- › Savings on runningcost via pre/post trade modes, limiting energy use by lights, air conditioning, ...
- › The most efficient open-door solution with Biddle air curtains



VRV for residential use

There is no place like home



A cost effective, low energy consumption heat pump system for home owners, offering maximum comfort

Our residential solution offers:

- › Lower CO2 emissions compared to traditional heating systems
- › Compact outdoor unit design with a low sound level
- › Whisper-quiet indoor units down to 19dBA
- › Daikin Emura, iconic design wall mounted unit
- › Unique Nexura floor standing unit offering the feel of a radiator with the efficiency of a heat pump
- › Units to be concealed in the wall or ceiling to make them completely unnoticed
- › User-friendly, intuitive control
- › Up to 9 indoor units that can be connected to one outdoor unit

Check on
YouTube

<https://www.youtube.com/DaikinEurope>



Upgrade R-22 and R-407C systems quick and qualitatively with...

VRV Replacement solutions:

- › Keep your customers operational even during system replacement
- › Less installation time
- › Lower installation costs
- › Replace non-Daikin systems
- › Automatic refrigerant charge and pipe cleaning



Which VRV

outdoor system offers me the best solution?

Heat recovery or heat pump?

VRV Heat recovery

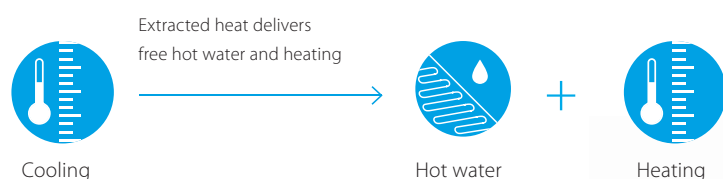

- > Simultaneous heating **AND** cooling from one system
- > "Free" heating and hot water production by transferring heat from areas requiring cooling
- > Maximum individual comfort in all areas
- > Technical cooling down to -20°C

Components:

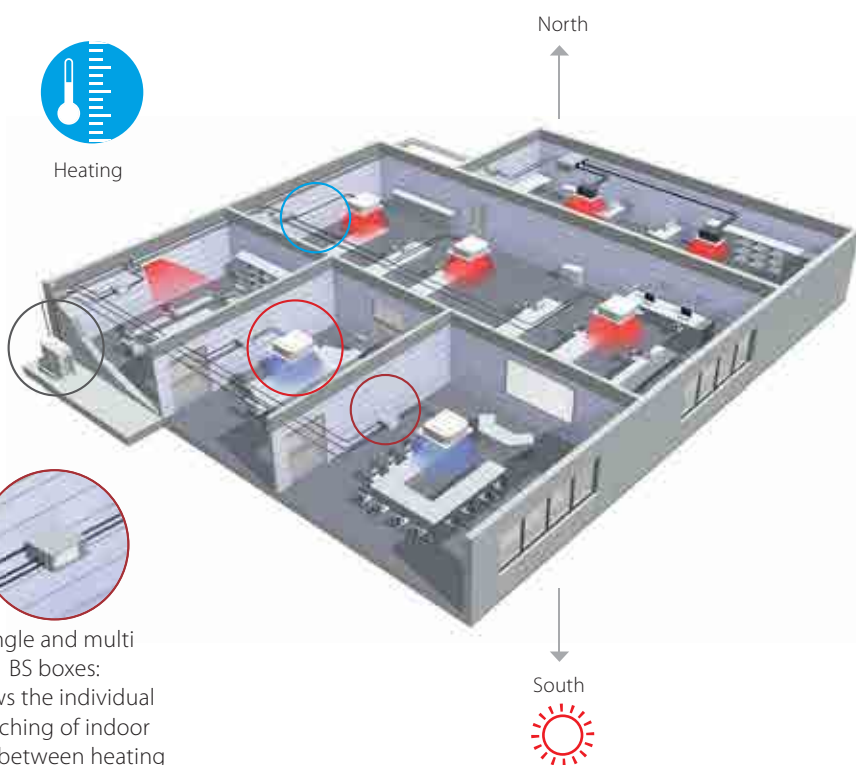
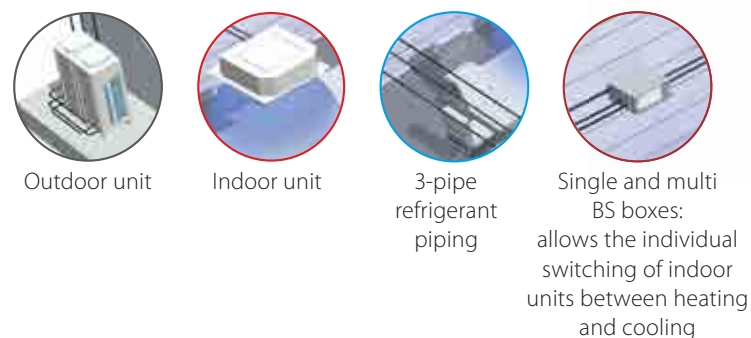

VRV Heat pump

- > For either heating **OR** cooling operation from one system

Components:

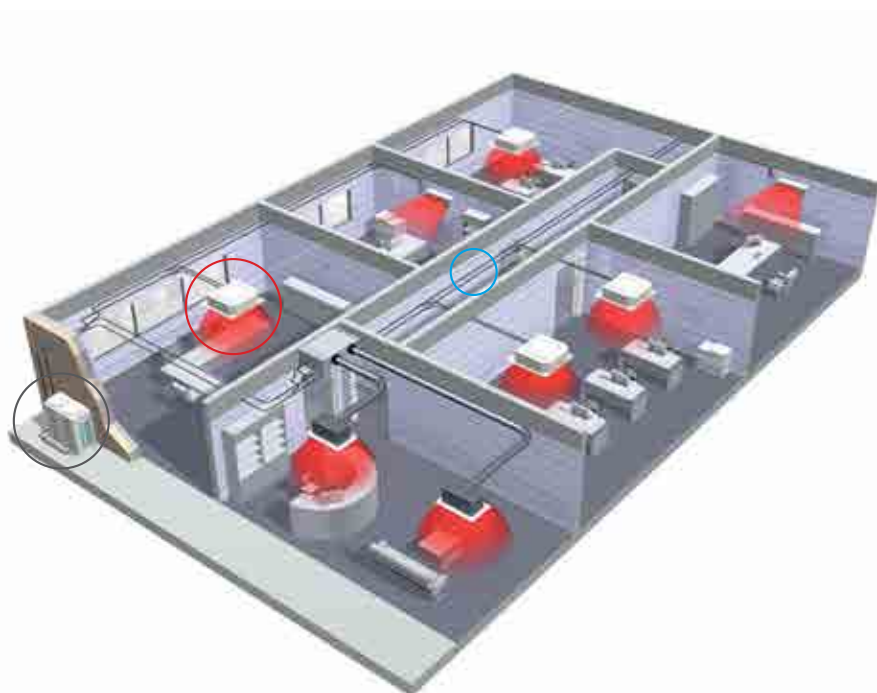
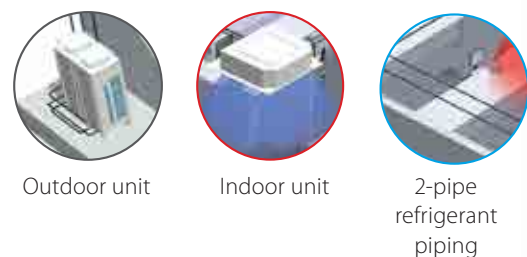

Air cooled or water cooled?

Air Cooled

- › Fast and easy to install, no need for additional components
- › Low maintenance costs
- › Operation range from -25°C~52°C
- › Can be installed both outdoors and indoors
- › Up to 54HP capacity for one system

Components:



Outdoor unit



Indoor unit



Refrigerant piping



Water Cooled

- › Suitable for multi-storey and large buildings because of the hardly unlimited possibilities of water piping
- › Not affected by outdoor temperature/climate conditions
- › Reduce CO₂ emissions thanks to the use of geothermal energy as a renewable energy source
- › Allows heat recovery in the entire building thanks to the storage of energy in the water circuit

Components:

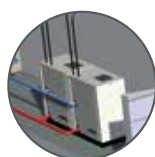

Outdoor unit

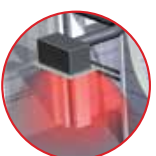

Indoor unit

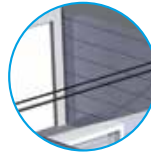

Refrigerant piping



(Geothermal) water loop



Products overview **VRV**

Model	Product name	4	5	6	8	10	12	13	14	16	18	20	22	24	26	28	30		
Air cooled - heat recovery	<p>Best efficiency & comfort solution</p> <ul style="list-style-type: none"> > Fully integrated solution with heat recovery for maximum efficiency > Covers all thermal needs of a building via a single point of contact: accurate temperature control, ventilation, hot water, air handling units and Biddle air curtains > "Free" heating and hot water through heat recovery > The perfect personal comfort for guests/tenants via simultaneous cooling and heating > Incorporates VRV IV standards & technologies such as Variable Refrigerant temperature and continuous heating > Allows technical cooling > Widest range of BS boxes on the market 	REYQ-T VRV IV																	
	<p>Daikin's optimum solution with top comfort</p> <ul style="list-style-type: none"> > Continuous heating during defrost > Covers all thermal needs of a building via a single point of contact: accurate temperature control, ventilation, hot water, air handling units and Biddle air curtains > Connectable to stylish indoor units (Daikin Emura, Nexura) > Incorporates VRV IV standards & technologies such as Variable Refrigerant temperature and continuous heating 	RYYQ-T VRV IV																	
	<p>Daikin's solution for comfort & low energy consumption</p> <ul style="list-style-type: none"> > Covers all thermal needs of a building via a single point of contact: accurate temperature control, ventilation, hot water, air handling units and Biddle air curtains > Connectable to stylish indoor units (Daikin Emura, Nexura) > Incorporates VRV IV standards & technologies such as Variable Refrigerant temperature 	RXYQ-T(9) VRV IV																	
Air cooled - heat pump	<p>Space saving solution without compromising on efficiency</p> <ul style="list-style-type: none"> > For residential and light commercial applications > Space saving design > Either connect VRV of stylish indoor units (Daikin Emura, Nexura) 	RXYSQ-P8V1/P8Y1 VRV III S																	
	<p>NEW</p> <p>Space saving solution without compromising on efficiency</p> <ul style="list-style-type: none"> > Space saving trunk design for flexible installation > Covers all thermal needs of a building via a single point of contact: accurate temperature control, ventilation, air handling units and Biddle air curtains > Either connect VRV of stylish indoor units (Daikin Emura, Nexura) > Incorporates VRV IV standards & technologies such as Variable Refrigerant temperature 	launch autumn 2015 RXYSQ-TV1/TY1 VRV IV S-series																	
	<p>NEW</p> <p>The most compact VRV</p> <ul style="list-style-type: none"> > Compact and lightweight single fan design saves space and is easy to install > Covers all thermal needs of a building via a single point of contact: accurate temperature control, ventilation, air handling units and Biddle air curtains > Either connect VRV of stylish indoor units (Daikin Emura, Nexura) > Incorporates VRV IV standards & technologies such as Variable Refrigerant temperature 	launch autumn 2015 RXYSQ-TV1 VRV IV S-series Compact																	
	<p>VRV III heat pump, optimised for heating</p> <ul style="list-style-type: none"> > Suitable for single source heating > Extended operation range down to -25°C in heating > Stable heating capacity and high efficiencies at low ambient temperatures 	RTSYQ-PA VRV III C																	
Replacement	<p>Classic VRV configuration</p> <ul style="list-style-type: none"> > For standard cooling & heating requirements > Connectable to VRV indoor units, controls and ventilation 	RXYCQ-A VRV Classic																	
	<p>Quick & quality replacement for R-22 and R-407C systems</p> <ul style="list-style-type: none"> > Cost-effective and fast replacement through re-use of existing piping > Up to 40% more efficient than R-22 systems > No interruption of daily business while replacing your system > Replace Daikin and other manufacturers systems safely 	RQCEQ-P* VRV III Q																	
	<p>Quick & quality replacement for R-22 and R-407C systems</p> <ul style="list-style-type: none"> > Cost-effective and fast replacement through re-use of existing piping > Up to 80% more efficient than R-22 systems > No interruption of daily business while replacing your system > Replace Daikin and other manufacturers systems safely > Incorporates VRV IV standards & technologies such as Variable Refrigerant temperature 	RXYQQ-T* VRV IV Q-series																	
Water cooled	<p>Ideal for high rise buildings, using water as heat source</p> <ul style="list-style-type: none"> > Reduced CO2 emissions thanks to the use of geothermal energy as a renewable energy source > No need for an external heating or cooling source when used in geothermal mode > Covers all thermal needs of a building via a single point of contact: accurate temperature control, ventilation, hot water, air handling units and Biddle air curtains > Compact & lightweight design can be stacked for maximum space saving > Incorporates VRV IV standards & technologies such as Variable Refrigerant temperature > Variable Water Flow control option increases flexibility and control 	RWEYQ-T* VRV IV W-series																	

* Not Eurovent certified















● Single unit
● Multi combination

Capacity (HP)													Description / Combination	VRV indoor units	Indoor units	LT Hydrobox HXY-A	HT Hydrobox HXHD-A	HRV units VAM-, VKM-	AHU connection EKE XV + EKEQMCB	AHU connection EKE XV + EKEQFCB	Air curtains CYV-DK-	Remarks
32	34	36	38	40	42	44	46	48	50	52	54											
													VRV IV Heat Recovery REYQ-T	○	×	○	○	○	○	×	○	† Standard total system connection ratio limit: 50 ~ 130%
													with only VRV indoor units	✓								
													with LT/HT Hydroboxes	✓		✓	✓	✓				† Max 32 indoor units, even on 16HP and larger systems † Total system connection ratio up to 200% possible
													HRV units VAM-, VKM-	✓		✓	✓	✓		✓		
●	●	●	●	●	●	●	●	●	●	●	●	●	AHU connection EKE XV + EKEQMCB	✓				✓	✓		✓	† Dedicated systems (with only ventilation units) not allowed – a mix with standard VRV indoor units is always necessary
													Biddle air curtain CYV-DK-	✓				✓	✓		✓	
													VRV IV Heat Pump RYYQ-T / RXYQ-T(9)	○	○	○	×	○	○	○	○	† Standard total system connection ratio limit: 50 ~ 130%
													with only VRV indoor units	✓								† 200% total system connection ratio possible under special circumstances
●	●	●	●	●	●	●	●	●	●	●	●	●	with residential indoor units	✓	✓			✓				† Only single-module systems (RYYQ 8~20 T / RXYQ 8~20 T) † Max 32 indoor units, even on 16HP, 18HP and 20HP systems
													with LT Hydroboxes	✓		✓		✓				† Max 32 indoor units, even on 16HP and larger systems † Contact Daikin in case of multi-module systems (>20HP)
													HRV units VAM-, VKM-	✓	✓	✓		✓	✓		✓	
													AHU connection EKE XV + EKEQMCB	✓				✓	✓		✓	
●	●	●	●	●	●	●	●	●	●	●	●	●	AHU connection EKE XV + EKEQFCB							✓		
													Biddle air curtain CYV-DK-	✓				✓	✓		✓	
													VRV III-S Mini VRV RXYQ-P8	○	○	×	×	○	○	×	○	† Standard total system connection ratio limit: 50 ~ 130%
													with VRV indoor units	✓				✓	✓		✓	
													with Split indoor units		✓							
													VRV IV-S Mini VRV	○	○	×	×	○	○	×	○	† Standard total system connection ratio limit: 50 ~ 130%
													with VRV indoor units	✓				✓	✓		✓	
													with Split indoor units		✓							
													VRV IV-S Mini VRV	○	○	×	×	○	○	×	○	† Standard total system connection ratio limit: 50 ~ 130%
													with VRV indoor units	✓				✓	✓		✓	
													with Split indoor units		✓							
													VRV III Cold Region RTSYQ-PA	✓	×	×	×	✓	✓	×	✓	† Standard total system connection ratio limit: 50 ~ 130%
													VRV Classic RXYCQ-A	✓	×	×	×	✓	×	×	×	† Standard total system connection ratio limit: 50 ~ 120% † In case of using at least one FXFQ20~25 indoor units on 8HP or 10HP models, the maximum connection ratio is 100%.
													VRV III-Q Replacement H/R RQCEQ-P	✓	×	×	×	✓	×	×	×	† Standard total system connection ratio limit: 50 ~ 130%
●	●	●	●	●	●								VRV IV-Q Replacement H/P RXYQQ-T	✓	×	×	×	✓	✓	×	✓	† Standard total system connection ratio limit: 50 ~ 130%
													VRV IV-W Water-cooled VRV RWEYQ-T	✓	×	×	×	✓	✓	×	✓	† Standard total system connection ratio limit: 50 ~ 130%

○ ... connection of indoor unit possible, but not necessarily simultaneously with other allowed indoor units
 ✓ ... connection of indoor unit possible even simultaneously with other checked units in the same row
 × ... connection of indoor unit not possible on this outdoor unit system

Products overview

Capacity class (kW)

Type	Model	Product name	15	20	25	32	40	50	63	71	80	100	125	140	200	250	
Ceiling mounted cassette	UNIQUE Round flow cassette	360° air discharge for optimum efficiency and comfort > Auto cleaning function ensures high efficiency > Intelligent sensors save energy and maximize comfort > Flexibility to suit every room layout > Lowest installation height in the market! 		•	•	•	•	•	•		•	•	•				
	UNIQUE Fully flat cassette	Unique design that integrates fully flat into the ceiling > Perfect integration in standard architectural ceiling tiles > Blend of iconic design and engineering excellence > Intelligent sensors save energy and maximize comfort > Small capacity unit developed for small or well-insulated rooms > Flexibility to suit every room layout 		•	•	•	•	•									
	2-way blow ceiling mounted cassette	Thin, lightweight design installs easily in narrow ceiling spaces > Depth of all units is 620mm, ideal for narrow ceiling spaces > Flexibility to suit every room layout > Reduced energy consumption thanks to DC fan motor > The flaps close entirely when the unit is not operating > Optimum comfort with automatic air flow adjustment to the required load 		•	•	•	•	•	•		•		•				
	Ceiling mounted corner cassette	1-way blow unit for corner installation > Compact dimensions enable installation in narrow ceiling voids > Flexible installation thanks to different air discharge options 				•	•	•	•								
Concealed ceiling	Small concealed ceiling unit	Designed for hotel rooms > Compact dimensions enable installation in narrow ceiling voids > Discretely concealed in the ceiling; only the grilles are visible > Flexible installation as the air suction direction can be altered from rear to bottom suction 		•	•												
	Slim concealed ceiling unit	Slim design for flexible installation > Compact dimensions enable installation in narrow ceiling voids > Medium external static pressure up to 44Pa > Only grilles are visible > Small capacity unit developed for small of well-insulated rooms > Reduced energy consumption thanks to DC fan motor 		•	•	•	•	•	•								
	NEW Concealed ceiling unit with medium ESP	Slimmest yet most powerful medium static pressure unit on the market! > Slimmest unit in class, only 245mm > Low operating sound level > Medium external static pressure up to 150Pa facilitates using flexible ducts of varying lengths > Automatic air flow adjustment function measures the air volume and static pressure and adjusts it towards the nominal air flow, guaranteeing comfort 		•	•	•	•	•	•		•	•	•	•			
	Concealed ceiling unit with high ESP	ESP up to 200, ideal for large sized spaces > Optimum comfort guaranteed no matter the length of ductwork or type of grilles, thanks to automatic air flow adjustment > Reduced energy consumption thanks to DC fan motor > Flexible installation as the air suction direction can be altered from rear to bottom suction 						•	•		•	•	•				
	Concealed ceiling unit with high ESP	ESP up to 270, ideal for extra large sized spaces > Only grilles are visible > Large capacity unit: up to 31.5 kW heating capacity 													•	•	
	Concealed ceiling unit with high efficiency	For the highest energy efficiency > Automatic air flow adjustment function guarantees comfort > Easy installation in narrow ceilings (245mm height) > High external static pressure up to 270Pa facilitates using flexible ducts of varying lengths > Only the suction and discharge grilles are visible 						•	•		•	•					
	Wall mounted	Wall mounted unit	For rooms with no false ceilings nor free floor space > Flat, stylish front panel is more easy to clean > Small capacity unit developed for small of well-insulated rooms > Reduced energy consumption thanks to DC fan motor > The air is comfortably spread up- and downwards thanks to 5 different discharge angles 		•	•	•	•	•	•							
		Ceiling suspended unit	For wide rooms with no false ceilings nor free floor space > Ideal for comfortable air flow in wide rooms thanks to Coanda effect > Rooms with ceilings up to 3.8m can be heated or cooled very easily! > Can easily be installed in both new and refurbishment projects > Can even be mounted in corners or narrow spaces without any problem > Reduced energy consumption thanks to DC fan motor 				•		•			•					
Ceiling suspended	UNIQUE 4-way blow ceiling suspended unit	Unique Daikin unit for high rooms with no false ceilings nor free floor space > Rooms with ceilings up to 3.5m can be heated up or cooled down very easily! > Can easily be installed in both new and refurbishment projects > Flexibility to suit every room layout > Reduced energy consumption thanks to DC fan motor 								•		•					
	Floor standing	Floor standing unit	For perimeter zone air conditioning > Can be installed in front of glass walls or free standing as both the front and the back are finished > Ideal for installation beneath a window > Requires very little installation space > Wall mounted installation facilitates cleaning beneath the unit 		•	•	•	•	•	•							
NEW Concealed floor standing unit		Ideal for installation in offices, hotels and residential applications > Discretely concealed in the wall, leaving only the suction and discharge grilles visible > Can even be installed underneath a window > Requires very little installation space as the depth is only 200mm > High ESP allows flexible installation 		•	•	•	•	•	•								
Cooling capacity (kW) ¹			1.7	2.2	2.8	3.6	4.5	5.6	7.1	8.0	9.0	11.2	14.0	16.0	22.4	28.0	
Heating capacity (kW) ²			1.9	2.5	3.2	4.0	5.0	6.3	8.0	9.0	10.0	12.5	16.0	18.0	25.0	31.5	



(1) Nominal cooling capacities are based on: indoor temperature: 27°CDB, 19°CWB, outdoor temperature: 35°CDB, equivalent refrigerant piping: 5m, level difference: 0m

(2) Nominal heating capacities are based on: indoor temperature: 20°CDB, outdoor temperature: 7°CDB, 6°CWB, equivalent refrigerant piping: 5m, level difference: 0m



Stylish indoor units overview

Depending on the application, Split and Sky Air indoor units can be connected to our VRV IV and VRV III-S outdoor units. Refer to the **outdoor unit portfolio** for combination restrictions.

Type	Model	Product name	Capacity class (kW)								Connectable outdoor unit				
			15	20	25	35	42	50	60	71	RYYQ-T	RXYQ-T(9)	RXYSQ-P8Y1 ³	RXYSQ-P8Y1 ³	
Ceiling mounted cassette	Round flow cassette (incl. auto-cleaning function ¹)	 FCQG-F				●			●	●				✓	✓
	Fully flat cassette	 FFQ-C			●	●			●	●				✓	✓
Concealed ceiling	Small concealed ceiling unit	FDBQ-B			●									✓	✓
	Slim concealed ceiling unit	FDXS-F(9)			●	●			●	●				✓	✓
	Concealed ceiling unit with inverter-driven fan	FBQ-D				●			●	●				✓	✓
Wall mounted	Daikin Emura Wall mounted unit	 FTXG-LW/LS		●	●	●			●			✓	✓	✓	✓
	Wall mounted unit	CTXS-K FTXS-K	●	●	●	●	●	●	●			✓	✓	✓	✓
	Wall mounted unit	FTXS-G								●	●	✓	✓	✓	✓
Ceiling suspended	Ceiling suspended unit	FHQ-C				●			●	●				✓	✓
	Nexura floor standing unit	FVXG-K			●	●			●			✓	✓	✓	✓
Floor standing	Floor standing unit	FVXS-F			●	●			●			✓	✓	✓	✓
	Flexi type unit	FLXS-B(9)			●	●			●	●		✓	✓	✓	✓

¹ Decoration panel BYCQ140CG + BRC1E52A/B needed

² To connect stylish indoor units a BPMKS unit is needed

³ For RXYSQ units a mix of RA indoor units and VRV indoor units is not allowed.



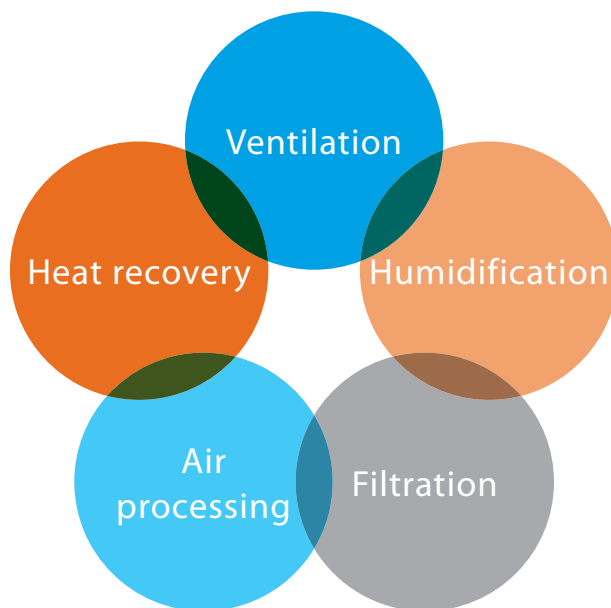

Ventilation range

Five components of indoor air quality

- › **Ventilation:** ensures the provision of fresh air
- › **Heat recovery:** recovers heat and moisture from the outgoing air to maximise comfort and efficiency
- › **Air processing:** heats or cools incoming fresh air maximising comfort and minimizing the load on the air conditioning installation
- › **Humidification:** optimises the balance between indoor and outdoor humidity
- › **Filtration:** removes dust, pollution and odours from the air



Air flow rate (m³/h)*



Type	Product name	Model	0	200	400	600	800	1,000	2,000	4,000	6,000	8,000	140,000	Components of indoor air quality
Heat reclaim ventilation	VAM-FA/FB	 <p>Ventilation with heat recovery as standard</p> <ul style="list-style-type: none"> › Energy saving ventilation › Maximise floor space for furniture, decoration and fittings › Free cooling › Reduced energy consumption thanks to DC inverter fan motor › Optional CO₂ sensor saves energy while improving indoor air quality 			[Bar from 200 to 1000]									› Ventilation › Heat recovery
	VKM-GB	 <p>Pre heating or cooling of fresh air for lower load on the air conditioning system</p> <ul style="list-style-type: none"> › Energy saving ventilation › Creates a high quality indoor environment › Maximise floor space for furniture, decoration and fittings › Free cooling › Reduced energy consumption thanks to DC inverter fan motor 			[Bar from 400 to 600]									› Ventilation › Heat recovery › Air processing
	VKM-GBM	 <p>Pre heating, cooling and humidification for optimum comfort</p> <ul style="list-style-type: none"> › Energy saving ventilation › Creates a high quality indoor environment › Balance your indoor humidity level › Maximise floor space for furniture, decoration and fittings › Free cooling 			[Bar from 400 to 600]									
Air handling units	DX total fresh air package	 <p>Fully customised solution for ventilation and air handling</p> <ul style="list-style-type: none"> › Inverter technology › Heat pump and heat recovery › Provides virtually free heating › Room temperature via Daikin control › Large range of expansion valve kits 			[Bar from 200 to 140000, with ** between 6000 and 140000]									› Ventilation › Heat recovery › Air processing › Humidification › Filtration

* Air flow rate is a calculated indication only, based on the following values: heating capacity EKEXV-kit * 200m³/h

** Daikin AHU connected to Daikin chiller solution

Additional options

Biddle air curtain range

Type	Product name	
Biddle air curtain free hanging	CYV S/M/L-DK-F	
Biddle air curtain cassette	CYV S/M/L-DK-C	
Biddle air curtain recessed	CYV S/M/L-DK-R	

- > A payback time of less than 1.5 years compared to electrical air curtains
- > Easy and quick installation
- > Maximum energy efficiency thanks to rectifier technology
- > 85% air separation efficiency
- > Cassette model (C): mounted into a false ceiling leaving only the decoration panel visible
- > Free-hanging model (F): easy wall mounted installation
- > Recessed model (R) : neatly concealed in the ceiling

Air curtain size selector

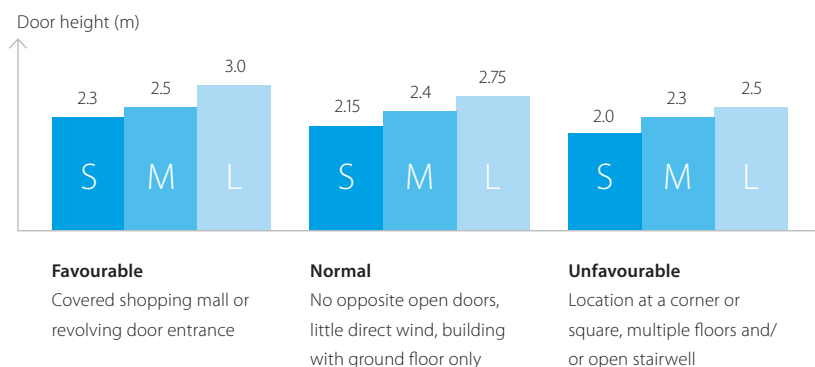

Hydrobox range

Capacity class (kW)

Type	Product name	Model	80	125	Leaving water temperature range
Low temperature hydrobox	HXY-A	<p>For high efficiency space heating and cooling</p> <ul style="list-style-type: none"> > Ideal for hot or cold water in underfloor, air handling units, low temperature radiators ... > Hot/cold water from 5° to 45°C > Large operation range (down to -20°C and up to 43°C) > Fully integrated water-side components save time on system design > Space saving contemporary wall hung design 	●	●	5°C - 45°C
High temperature hydrobox	HXHD-A	<p>For efficient hot water production and space heating</p> <ul style="list-style-type: none"> > Ideal for hot water in bathrooms, sinks and for underfloor heating, radiators, air handling units, ... > Hot water from 25 to 80°C > "Free" heating and hot water through heat recovery > Uses heat pump technology to produce hot water efficiently, providing up to 17% savings compared to a gas boiler > Possibility to connect thermal solar collectors 		●	25°C - 80°C

Network solutions

Type		ITC	ITM	DMS-IF	BACNET
Screen	Layout screen		●		
	Touch screen	●	●		
Integration	Mini BMS for heating, air conditioning applied systems and refrigeration units (BACnet and WAGO)		●		
	3rd party equipment integration (BACnet and WAGO)		●		
Control	Basic control functions: on/off, temp, setting, air flow settings	●	●	●	●
	Refrigerant containment check		●		
	Temperature limitation	●	●		
	Setback		●		
	Automatic changeover	●	●		
	Weekly schedule and special day pattern	●	●		
	Timer extension		●		
Monitoring	Forced off	●	●	●	●
	Basic control functions: ON/OFF status, operation mode, set point temp.	●	●	●	●
	Filter status	●	●	●	●
	Malfunction code	●	●	●	●
	History (operation, malfunction...)	●	●		
Options	Visualisation	●	●		
	PPD	●			●
	Web access and control	●	Std		
Other	HTTP option	●			
	Interlock	●	●		
	Pre-cool/heat		●		
	Sliding temperature		●		
	Free cooling	●	●		
	ACNSS connection Air Conditioning Network Service System	●	●	●	●
Maximum indoor unit groups	64	2560	64	4x64	



VRV IV standard & technologies

Our new VRV IV systems set pioneering standards in all-round climate comfort performance. Total design simplicity, offering rapid installation, full flexibility as well as absolute efficiency and comfort. Find out about all these revolutionary changes at

www.daikineurope.com/vrviv

VRV IV =

3 revolutionary standards

- › Variable refrigerant temperature
- › Continuous comfort during defrost
- › VRV configurator

+ unique VRV IV core technologies

- > Newly developed inverter compressor
- > Refrigerant-cooled PCB
- > 4-side heat exchanger
- > Predictive control
- > Outer rotor DC motor

Variable refrigerant temperature



Customise your VRV for best seasonal efficiency and comfort

Thanks to its revolutionary variable refrigerant temperature technology (VRT), VRV IV continuously adjusts both the inverter compressor speed and the refrigerant temperature, providing the necessary capacity to meet the building load with the highest seasonal efficiency at all times!

- › **Seasonal efficiency increased by 28%**
- › **The first weather compensating control on the market**
- › **Customer comfort is assured thanks to higher outblow temperatures (preventing cold draughts)**

How does it work?

VRV standard

Capacity is controlled only with the variance of the inverter compressor

Daikin VRV IV

Variable Refrigerant Temperature control for energy saving in partial load condition. The capacity is controlled by the inverter compressor AND variation of the evaporating (T_e) and condensing (T_c) temperature of the refrigerant in order to achieve the highest seasonal efficiency.



Calculate the benefit of variable refrigerant temperature for your project in our seasonal solutions calculator:

<http://extranet.daikineurope.com/en/software/downloads/solutions-seasonal-simulator/default.jsp>

Success story

Live test: up to 46% less energy consumed

A field trial was carried out at a fashion store chain in Germany and showed that the innovative Daikin VRV IV delivers dramatically better energy efficiency compared with previous models.

The trial results showed that the new VRV IV system consumed up to 60% less energy than the VRV III system, particularly during cooling. Overall energy savings during heating averaged 20%.

How effective is the VRV IV heat pump technology?

The trial demonstrated that by using air, an infinitely renewable and free energy source, the VRV IV system provides a complete and environmentally sustainable solution for heating, cooling and ventilation in commercial applications. The trial also showed that only by monitoring climate control systems carefully and intelligently businesses can identify and control energy waste. This is a service which Daikin also offers.

The colder it gets, the lower the load on the building and the lower the capacity need

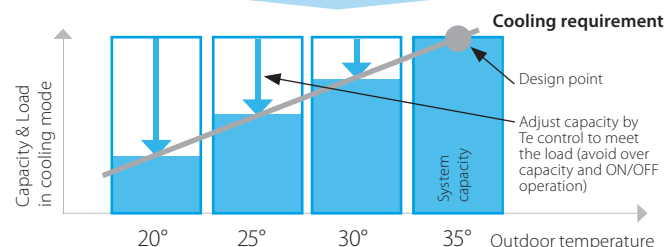

The lower the capacity need the higher the refrigerant temperature can be

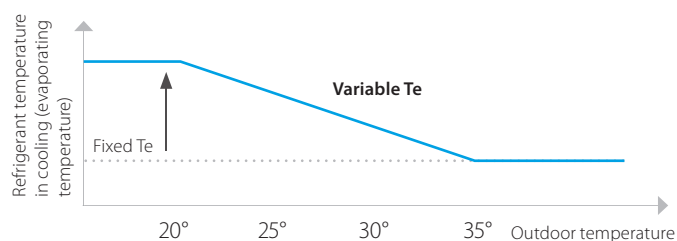

A higher refrigerant temperature results in a higher seasonal efficiency and higher comfort

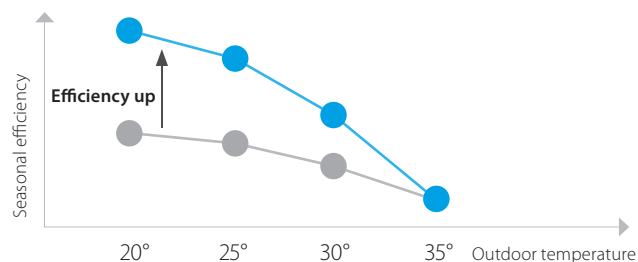

Different modes to maximise efficiency and comfort

For maximum energy efficiency and customer satisfaction, the outdoor unit needs to adapt the evaporating/condensing temperature at the optimum point for the application.



Check on
YouTube

<https://www.youtube.com/DaikinEurope>

How to set the different modes?

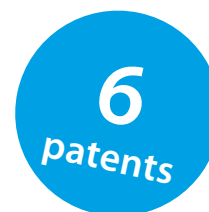

Set up the main operation mode of the system	Define how the system reacts to changing loads	
<p>Step 1</p> <p>Automatic*</p> <p>Quick reaction speed Top efficiency</p> <p>The perfect balance: Achieves top efficiency throughout the year, reacts quickly on the hottest days</p>	<p>Step 2</p> <p>Powerful</p> <p>Quick</p> <p>Mild *</p>	<p>Where a quick increase of load is expected such as conference rooms. Quick reaction speed to changing load has priority, with temporarily colder outblow as a result.</p> <p>Same as above but slower response than the powerful mode.</p> <p>This mode would be suitable for most office applications and it is the factory set mode. The perfect balance: Slower reaction speed with top efficiency</p>
<p>High sensible (User selection)</p> <p>Quick reaction speed Top efficiency</p> <p>Year round top efficiency</p>	<p>Powerful</p> <p>Quick</p> <p>Mild</p> <p>Eco</p>	<p>Gives customer choice for fixing coil temperature which avoids cold draughts. A quick reaction speed to changing load has priority, with temporarily colder outblow as a result.</p> <p>Same as above but slower response.</p> <p>The air off temperature remains fairly constant. Suitable for low ceiling rooms.</p> <p>Coil temperature would not change due to fluctuating load. Suitable for computer rooms. Suitable for low ceiling rooms.</p>
<p>Basic Current VRF standard</p>	<p>No submodes</p>	<p>This is how most other VRF systems work and can be used for all general type of applications. Suitable for computer rooms. Suitable for low ceiling rooms.</p>

* Factory setting

	VRV III 20HP (2 modules)	VRV IV 18HP (1 module)
Period	March 2012 - February 2013	March 2013 - February 2014
Avg (kWh/Month)	2.797	1.502
Total (kWh)	33.562	18.023
Total (€)	6.041	3.244
Yearly (operation cost/m² (€/m²))	9,9	5,3
46% savings = € 2.797		

Measured data

Fashion store Unterhaching (Germany)

- › Floor space: 607m²
- › Energy cost: 0,18 €/kWh
- › System taken into account for consumption:
 - VRV IV heat pump with continuous heating
 - Round flow cassettes (without auto cleaning panel)
 - VAM for ventilation (2x VAM2000)
 - Biddle Air curtain.

Continuous heating during defrost mode

VRV IV continues to provide heating even when in defrost mode, providing an answer to any perceived disadvantages of specifying a heat pump as a monovalent heating system.

- › Indoor comfort not affected either via the unique heat accumulating element or alternate defrost
- › The best alternative to traditional heating systems



Check on
YouTube

<https://www.youtube.com/DaikinEurope>

Heat pumps are known for their high energy efficiency in heating, but they accumulate ice during heating operation and this must be melted periodically using a defrost function that reverses the refrigeration cycle. This causes a temporary temperature drop and reduced comfort levels inside the building.

Defrosting can take over 10 minutes (depending on the size of the system) and occurs mostly between -7 and +7°C when there is most moisture in the air, which freezes to the coil, and this has a significant impact on the perceived indoor comfort levels and running costs.

The VRV IV has changed the heating paradigm by providing heat even during defrost operation thus eliminating the temperature drop inside and providing comfort at all times.

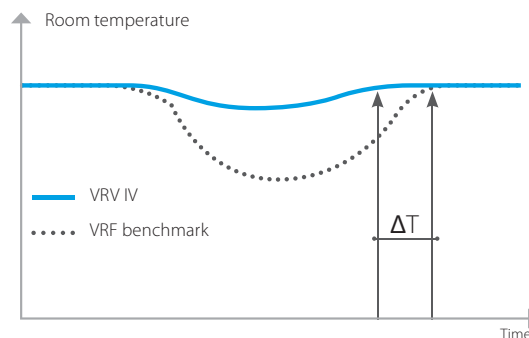

How does it work?

Heat accumulating element

For the VRV IV heat pump single models a unique heat-accumulating element is used. This element, based upon phase change materials, provides the energy to defrost the outdoor unit. The energy needed for defrosting is stored in the element during normal heating operation.

The outdoor unit coil is defrosted ...

... with the energy stored in the heat accumulating element ...

... while indoors a comfortable temperature is maintained.

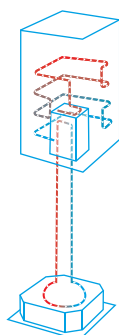

Alternate defrost

On all our multi model combinations only 1 outdoor coil is defrosted at a time, ensuring continuous comfort during the whole process.

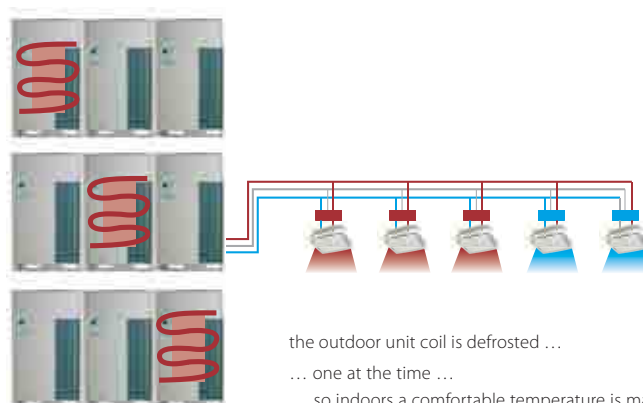

the outdoor unit coil is defrosted ...

... one at the time ...

... so indoors a comfortable temperature is maintained

Configurator software

Software for simplified commissioning, configuration and customisation

- › **Graphical interface**
- › **Manage systems over multiple sites in exactly the same way**
- › **Retrieve initial settings**



**Check on
YouTube**

<https://www.youtube.com/DaikinEurope>

Simplified commissioning

The VRV configurator is an advanced software solution that allows for easy system configuration and commissioning:

- › less time is required on the roof configuring the outdoor unit
- › multiple systems at different sites can be managed in exactly the same way, thus offering simplified commissioning for key accounts
- › initial settings on the outdoor unit can be easily retrieved.

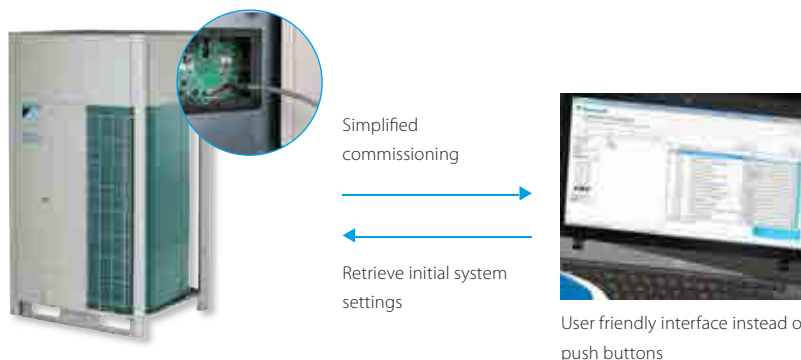

Simplified servicing

Outdoor unit display for quick on-site settings and easy read out of errors together with the indication of service parameters for checking basic functions.

- › easy-to-read error report
- › clear menu indicating quick and easy on-site settings
- › indication of basic service parameters to quickly check basic functions: high pressure, low pressure, frequency and operation time history of compressors, temperature of discharge/suction pipe.



Unique VRV IV core technologies



Newly developed compressor

37 patents

Full inverter

- › Enabling variable refrigerant temperature and low start-up currents
- › Stepless capacity control

Reluctance brushless DC motor

- › increased efficiency compared to AC motors by simultaneously using normal and reluctance torque
- › Powerful neodymium magnets efficiently generate high torque
- › High-pressure oil reduces thrust losses

High efficiency J-type 6-pole motor

- › 50% stronger magnetic field and higher rotation efficiency

Thixocasting process

- › Compression volume is increased by 50% thanks to a new high-durability material cast in a semi-molten state



Refrigerant-cooled PCB

- › Reliable cooling because it is not influenced by ambient air temperature
- › Smaller switchbox for smoother air flow through the heat exchanger increasing heat exchange efficiency with 5%

6 patents

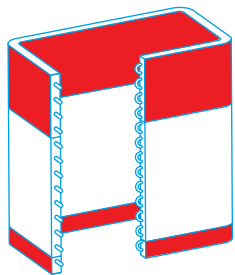

4-sided, 3-row heat exchanger

- › Heat exchange surface up to 50% larger
- › (up to 235m²), leading to 30% more efficiency

10 patents



UNIQUE

Predictive Control Function (PCF)

- › Reaches the target capacity/refrigerant temperature faster
- › Reaches the target without overshooting, so there is no waste, leading to improved efficiency
- › Three capacity settings give more precise control for user comfort

The large number of Daikin systems already in operation and which are monitored by our i-Net software put us in the unique position of being able to analyse this data and develop the predictive compressor control function.

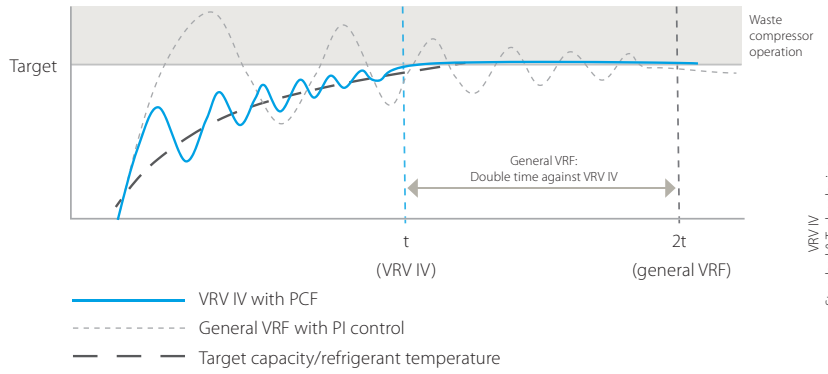

VRV IV: PCF

Compressor works with predictive data for the control

- › result: quick convergence to the target temperature and reduction of waste operation of the compressor

Half time against general VRF

General VRF: Pi control

Compressor works with feedback only for the control

- › result: waste operation and longer time before reaching target set point

DC fan motor

UNIQUE

Outer rotor DC motor for higher efficiency

- › Larger rotor diameter results in greater force for the same magnetic field, leading to better efficiency
- › Better control, resulting in more fan steps to match the actual capacity

Sine wave DC inverter

Optimizing the sine wave curve results in smoother motor rotation and improved motor efficiency.

DC fan motor

The use of a DC fan motor offers substantial improvements in operating efficiency compared to conventional AC motors, especially during low speed rotation.

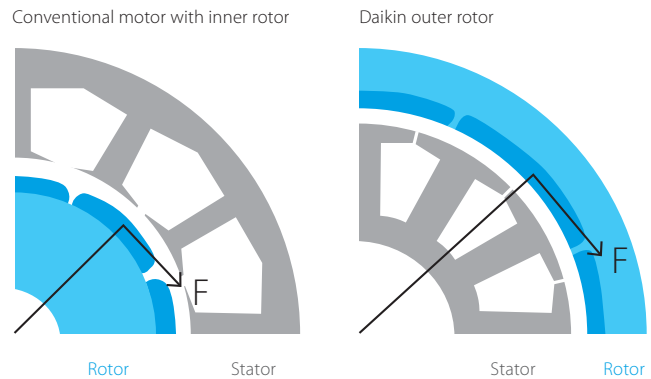

E-Pass heat exchanger

Optimising the heat exchanger's path layout prevents heat being transferred from the overheated gas section to the sub-cooled liquid section which is a more efficient way to use the heat exchanger.

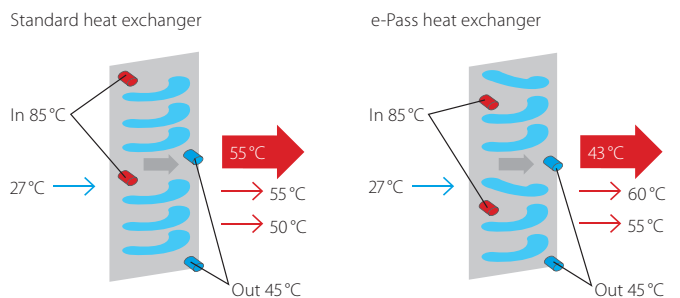

I-demand function

Limit maximum power consumption. The newly introduced current sensor minimizes the difference between the actual power consumption and the predefined power consumption.

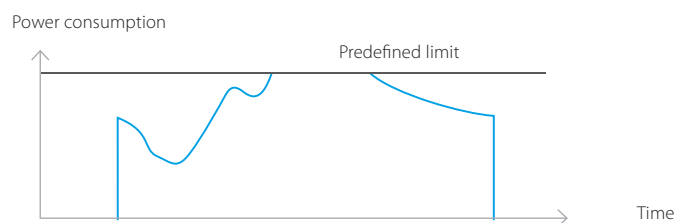



The VRV benefits

See how you can profit from Daikin's highly flexible and efficiency product range

VRV

Latest technology, highest efficiency

VRV, a total commercial solution

Drastically reducing your running costs	32
Top reliability	32
Up to 6 times greater resistance against corrosion	32
Comfort guaranteed at all times	37
Maximum flexibility	36
Fast installation and commissioning	38
Easy servicing	38

- Drastically reducing your running costs
- Top reliability
- Up to 6 times greater resistance against corrosion

Precise zone control

VRV systems have low running costs because it permits each zone to be controlled individually. That is, only those rooms that require air conditioning will be heated or cooled, while the system can be shut down completely in rooms where no air conditioning is required.

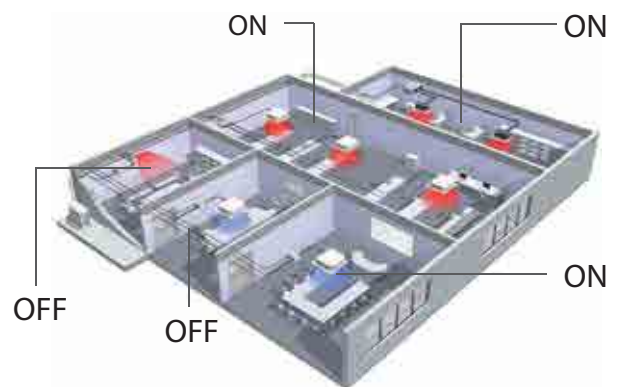

Anti Corrosion Treatment

Special anti corrosion treatment of the heat exchanger provides 5 to 6 times greater resistance against acid rain and salt corrosion.

The provision of rust proof steel sheet on the underside of the unit gives additional protection.

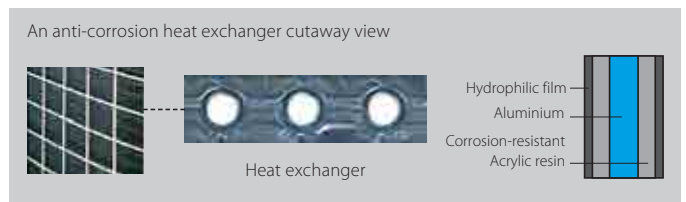

Performed tests:

- > VDA Wechseltest
- > Contents of 1 cycle (7 days):
- > 24 hours salt spray test SS DIN 50021
- > 96 hours humidity cycle test KFW DIN 50017
- > 48 hours room temperature & room humidity testing period: 5 cycles

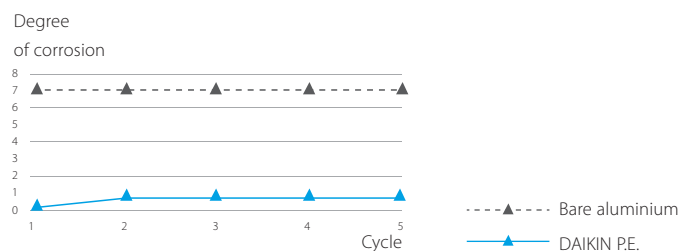

Kesternich test (SO2)

- > contents of 1 cycle (48 hours) according to DIN50018 (0.21)
- > testing period : 40 cycles

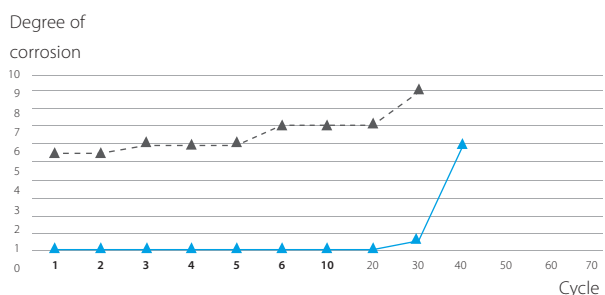

All inverter compressors

All inverter control compressors allow to control the refrigerant volume almost stepless. In this way the capacity perfectly matches the different loads in every room avoiding unnecessary energy use.

Additionally all inverter compressors also allow precise refrigerant temperature control, automatically adapting your VRV to your building and climate requirements, reducing running costs with 28%.

ALL

INVERTER



Only one power supply

Duty Cycling extends operation life

The cyclical start-up sequence of multiple outdoor units systems equalises compressor duty and extends operating life.

Sequential Start

Up to 3 outdoor units can be connected to 1 power supply and can be turned on sequentially. This allows the number of breakers and their capacities to remain small and simplifies wiring (for models of 10HP or less).

Top quality Only brazed connections

All flange and flare connections inside the unit have been replaced by brazing connections to ensure improved refrigerant containment. Also the connection of the outdoor in the main pipe is brazed.

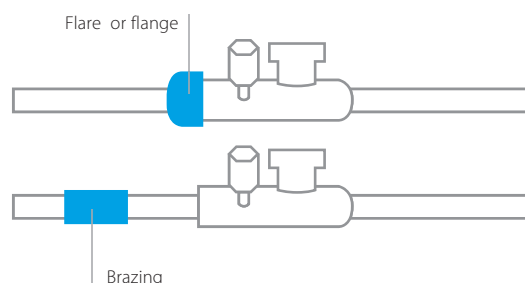

• Comfort guaranteed at all times

Smart Control brings comfort

Stable room temperature

An electronic expansion valve, using PID (Proportional Integral Differential) control, continuously adjusts the refrigerant volume in response to load variations of the indoor units. The VRV system thus maintains comfortable room temperatures at a virtually constant level, without the temperature variations typical of conventional ON/OFF control systems.

Note: The graph shows the data, measured in a test room assuming actual heating load. The thermostat can control stable room temperature at $\pm 0.5^\circ\text{C}$ from set point.

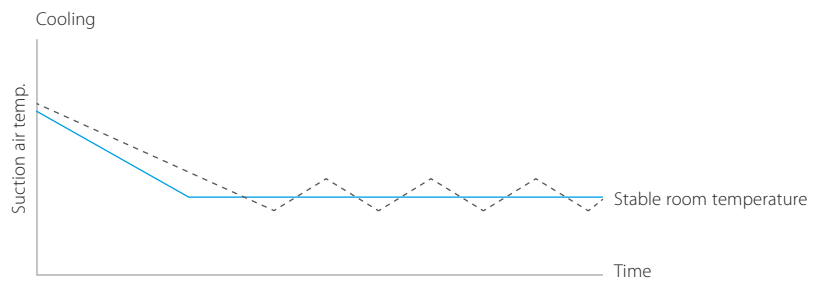

— VRV SERIES (DAIKIN indoor unit (PID controlled))
 - - - ON/OFF controlled indoor unit (2.5HP)

No more cold draught

Automatic or manual adjustment of refrigerant temperature leads to higher outblow temperatures which avoid the cold draught coming from the indoor unit.

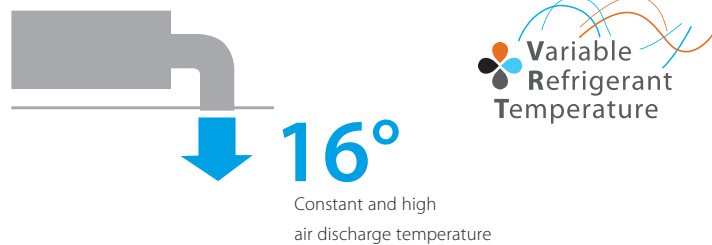

Continuous heating

During defrost

- › Indoor comfort not effected via the unique heat accumulating element or alternate defrost
- › The best alternative to traditional heating systems

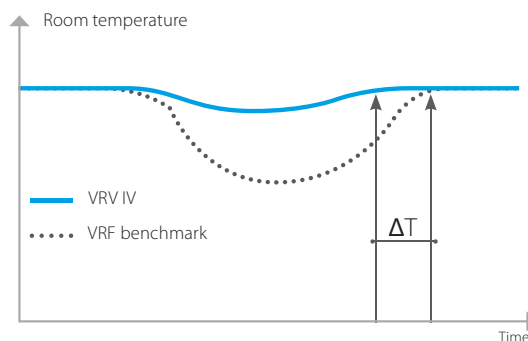

Back-up function

In the event of a compressor malfunction another compressor or outdoor unit will take over in order to maintain 8 hour interim capacity, allowing time for maintenance or repair while comfort remains guaranteed.

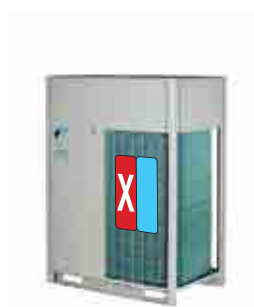

Single outdoor unit with multiple compressors



Multi outdoor unit system

Low indoor unit operation sound level

Daikin indoor units have very low sound operation levels, **down to 19dB(A)**, making them ideal for sound sensitive areas as hotel bedrooms, etc...

db(A)	Perceived loudness	Sound
0	Threshold of hearing	-
20	Extremely soft	Rustling leaves
40	Very soft	Quiet room
60	Moderately loud	Normal conversation
80	Very loud	City traffic noise
100	Extremely loud	Symphonic orchestra
120	Threshold of feeling	Jet taking off

Daikin indoor units:



19dB(A)

Connectable to VRV IV and VRV III-S heat pump



25.5dB(A)

Connectable to all VRV heat pumps

Night quiet mode

For areas where there are stringent limitations to sound levels the outdoor unit sound level can be reduced, to meet the requirement.

- Capacity* %
- Load %
- Operation Sound dBA

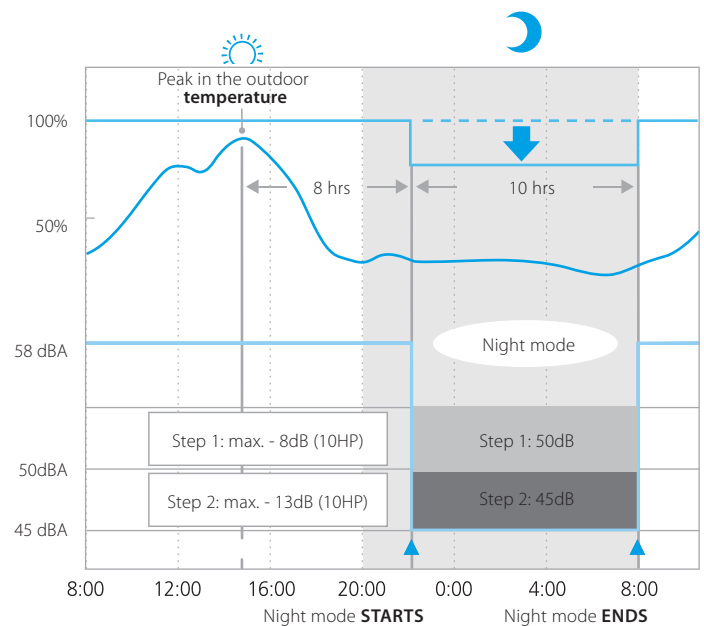

Example for VRV IV heat pump, factory setting.

• Maximum flexibility

Wide operation range

The VRV system can be installed practically anywhere. VRV air cooled outdoor units can cool between -20°C and +52°C outdoor ambient and can be used monovalent heating system between -25°C and +15.5°C.

Our geothermal water cooled units are not influenced by external conditions and can be operated in the most extreme climates.

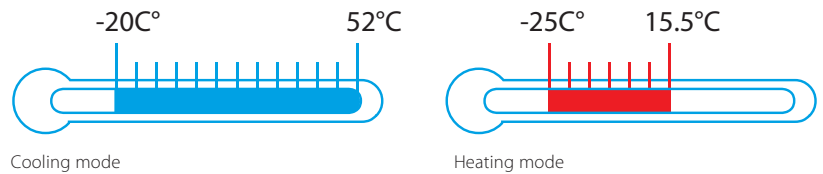

With the technical cooling function, the operation range in cooling of the heat recovery system is extended from -5°C to -20°C¹, making it perfect for integrating server rooms.

Flexible piping design

The long piping lengths, high level differences and small refrigerant piping allows for a design with little limitations and leaving maximum space for lettable space.

¹ Contact your local dealer for more information and restrictions

VRV IV example

Total piping length	1000m
Longest length actual (Equivalent)	165m (190m)
Longest length after first branch	90m ¹
Level difference between indoor and outdoor units	90m ¹
Level difference between indoor units	30m

¹ Contact your local dealer for more information and restrictions

² In case outdoor unit is located below indoor units

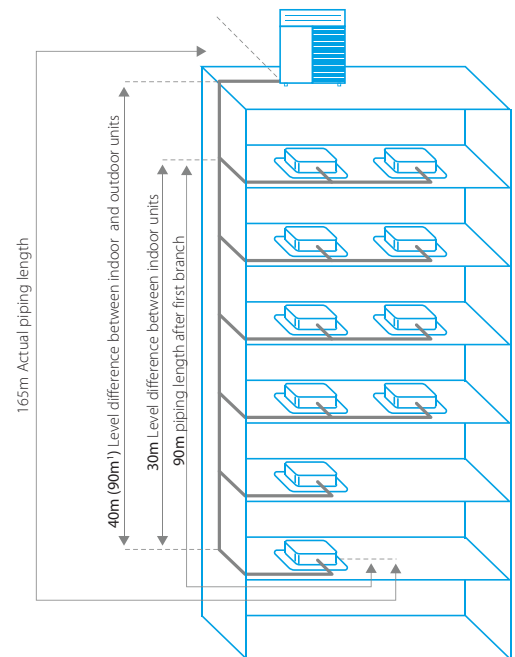

Indoor installation

The VRV optimised fan blade shape increases output and reduces pressure loss. Together with the high ESP setting (up to 78pa), it makes VRV outdoor units ideal for indoor installation using ducts.

Indoor installation leads to less piping length, lower installation costs, increased efficiency and better visual aesthetics.



Multiple tenants, one outdoor unit

The multi tenant function ensures that the entire VRV system does not shut down when the main power supply of an indoor is switched off. This means that the indoor unit's main power supply can be turned off when a part of the building is closed, is being serviced without affecting the rest of the building.

2 solutions according to the needs:

- › Service setting, without additional hardware: for service done within 24 hours
- › PCB option: when tenants leave for a longer period (holiday) and the main power supply is shut down

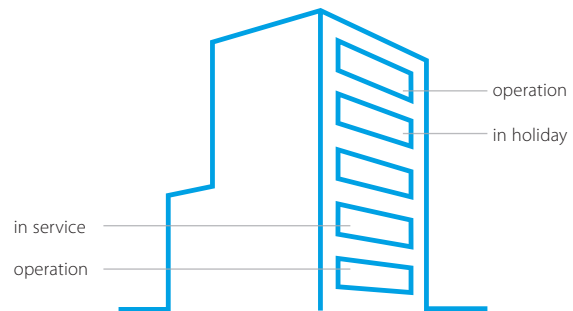

No structural reinforcement necessary

Thanks to the vibration-free and sufficient light construction of the outdoor units, floors do not need to be reinforced, reducing the overall cost of the building when compared to a chiller.



Phased installation

Installation of the VRV system can be implemented floor by floor, so that sections of the building can be put into use very quickly, or enabling the air conditioning system to be commissioned and operated in stages, rather than on final completion of the project.

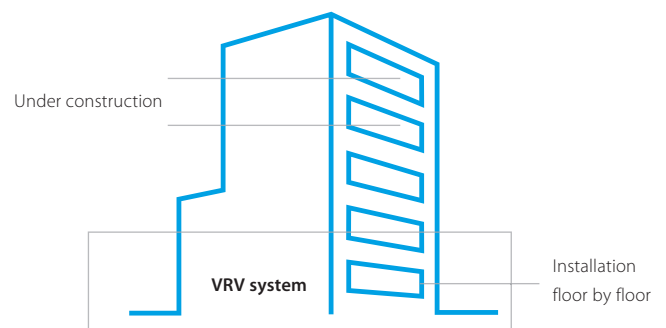

- Fast installation and commissioning
- Easy servicing

Automatic charging & testing

Efficient use of time

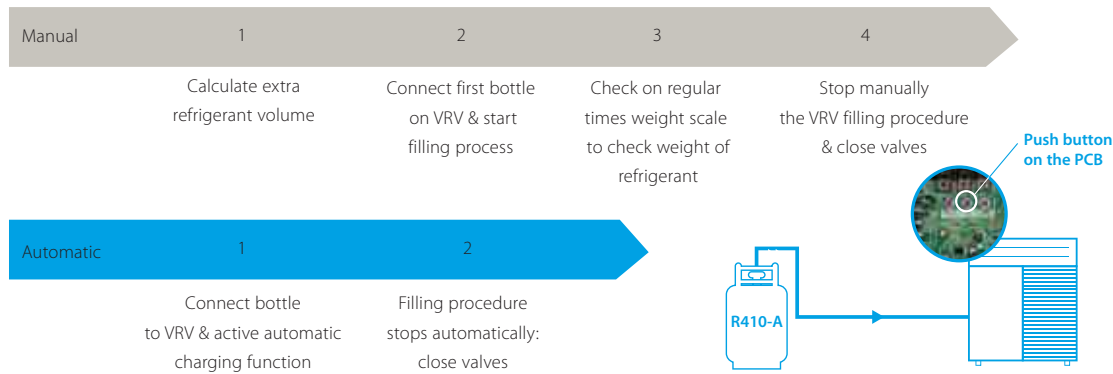

After charging pushing the test operation button initiates a check on the wiring, shut off valves, sensors and refrigerant volume.

If the temperature drops below 20°C* manual charging is necessary.

* 10°C for heat pump for cold regions

* Not available for VRV Classic and VRV IV W-series

Did you know ...

Optimal charge = optimal efficiency

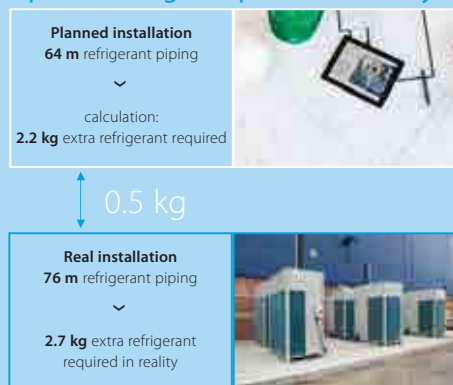

10% undercharged

up to 25% capacity loss

33% more energy use

Easy compliance to F-gas regulation

Remote refrigerant containment check

Perform the refrigerant containment check remotely via Intelligent Touch Manager.

When activating the refrigerant containment check, the unit switches into cooling mode and duplicates certain reference conditions based on memory data. The result indicates whether or not refrigerant leakage has occurred.

The refrigerant volume of the complete system is calculated for the following data:

- > Outdoor temperature
- > Reference system temperatures
- > Reference pressure temperatures
- > Refrigerant density
- > Types and number of indoor units



Remotely set the time and start the refrigerant containment check when it is most convenient for you.

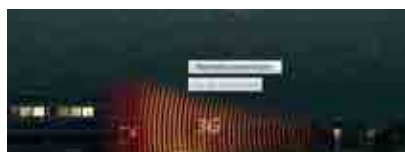

Connect to customer site via internet or 3G increasing customer satisfaction as there is no disruption to the air conditioning during business hours.



Check the report once the check has been done.

Not available on VRVIII-S or in combination when one or more RA indoor units, hydroboxes, ... are connected
Next to remote checking, the function can also be activated on-site via a push button on the PCB.

VRV configurator software

For simplified commissioning, configuration and customisation



User friendly interface instead of push buttons



3 digit 7-segment display

Compact design

The compact design of the outdoor units is sufficient to allow them to be taken up to the top of a building in a commercial elevator, overcoming site transportation problem, particularly when outdoor units need to be installed on each floor.



Daikin unified REFNET piping

The unified Daikin REFNET piping system is designed for simple installation.

Compared to regular T-joints, where refrigerant distribution is far from optimal, the Daikin REFNET joints have specifically been designed to optimise refrigerant flow.

Daikin Europe N.V. advises only to use Daikin REFNET piping system.

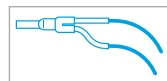

REFNET joint

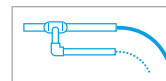

T-joint



REFNET joint



REFNET header

Easy wiring - "Super Wiring" System

Simplified wiring

Shared use of wiring between indoor units, outdoor units and centralised remote control

- > Easy retrofit of centralised remote control
- > Impossible to make incorrect connections thanks to non polarity wiring
- > Sheeted wire can be used
- > Unique total wiring length up to 2,000 m

Cross wiring check

The cross wiring check facility warns operatives of connection errors in inter unit wiring and piping.

Auto Address Setting Function

Allows wiring between indoor and outdoor units, as well as group control wiring of multiple indoor units, to be performed without the bothersome task of manually setting each address.





VRV Outdoor Systems

For every application a solution

Overview of functions

	VRV IV Heat recovery	VRV IV heat pump with continous heating	VRV IV heat pump without continous heating	VRV III-S	VRV III-C	VRV Classic	Replacement VRV IV heat pump	Replacement VRV III Heat recovery	Water cooled VRV IV
	p 44	p 54	p 54	p 62	p 70	p 76	p 81	p 81	p 92
Variable Refrigerant Temperature	●	●	●	✘	✘	✘	●	✘	●
Continuous heating (heat accumulating element)	✘	●	✘	✘	✘	✘	✘	✘	-
Continuous heating (alternate defrost)	●	●	✘	✘	✘	✘	✘	✘	-
VRV configurator	●	●	●	✘	✘	✘	●	✘	●
7 segment indicator	●	●	●	✘	✘	✘	●	✘	✘
Automatic refrigerant charge	●	●	●	●	●	✘	●	●	✘
Refrigerant containment check	●	●	●	●	●	✘	✘	✘	✘
Night quiet mode	●	●	●	●	●	✘	●	●	-
Low noise function	●	●	●	●	●	●	●	●	-
Connectable to stylish indoor units (Daikin Emura, Nexura)	✘	●	●	●	✘	✘	✘	✘	✘
Connectable to LT hydrobox for hot water	●	●	●	✘	✘	✘	✘	✘	✘
Connectable to HT hydrobox for hot water	●	✘	✘	✘	✘	✘	✘	✘	✘
Full inverter compressors	●	●	●	●	✘	✘	●	●	●
Gas cooled PCB	●	●	●	✘	✘	✘	●	✘	✘
4 side heat exchanger	●	●	●	✘	✘	✘	●	✘	-
Reluctance brushless DC compressor	●	●	●	●	●	●	●	●	●
Sine wave DC inverter	●	●	●	●	●	●	●	●	●
DC fan motor	●	●	●	●	●	●	●	●	-
E-pass heat exchanger	●	●	●	●	●	●	●	●	-
I demand function	●	●	●	●	●	✘	●	●	✘
Manual demand function	●	●	●	●	●	●	●	●	●



EIFPAGE OFFICE,
VRV IV WITH CONTINUOUS HEATING



VRV-S SERIES



PARK PHI
BREAM® EXCELLENT OFFICE
BUILDING WATERCOOLED VRV



HOTEL LE PIGONNET, 8 REPLACEMENT VRV



CINEMEERSE, CINEMA, 12 OUTDOOR UNITS WITH AHU



THE RANGE SUPERSTORE, VRV IV WITH CONTINUOUS HEATING

VRV IV heat recovery

Best efficiency and comfort solution

Efficient
3-pipe
technology

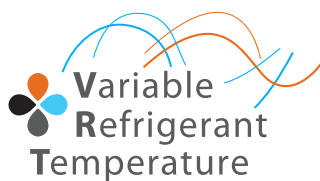

VRV IV standards:

Variable refrigerant temperature

Customize your VRV for best seasonal efficiency & comfort

Continuous heating

The new standard in heating comfort

VRV configurator

Software for simplified commissioning, configuration and customisation

- > 7 segment indicator
- > Automatic refrigerant charge
- > Refrigerant containment check
- > Night quiet mode
- > Low noise function
- > Full inverter compressors
- > Gas cooled PCB
- > 4 side heat exchanger
- > Reluctance brushless DC compressor
- > Sine wave DC inverter
- > DC fan motor
- > E-pass heat exchanger
- > I demand function

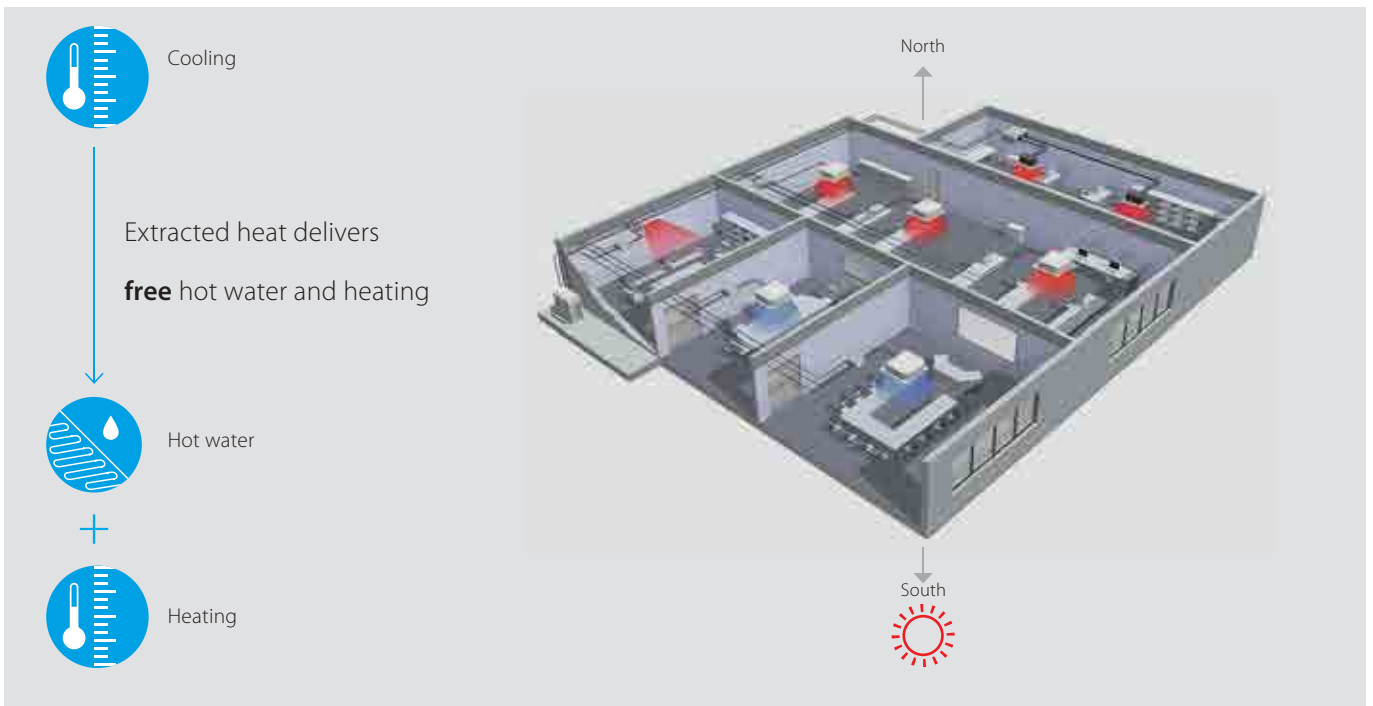

“Free” heat and hot water production

Until now, most commercial buildings have relied on separate systems for cooling, heating, hot water and so on, which results in a lot of wasted energy.

An integrated heat recovery system reuses heat from offices, server rooms, to warm other areas or create hot water.

Improved efficiency

In heat-recovery operation the VRV IV is up to 15% more efficient. In full-load operation the seasonal efficiency is even as much as 28% more efficient than the VRV III thanks to variable refrigerant temperature.

Optimised Partition of Heat Exchanger for highest seasonal efficiency in heat recovery mode

Vertically divided heat exchanger with an optimized ratio for mix mode operation. This improves heat recovery efficiency by reducing radiation losses.

Maximum comfort

A VRV heat-recovery system allows simultaneous cooling and heating.

- › For hotel owners, this means a perfect environment for guests as they can freely choose between cooling or heating.
- › For offices, it means a perfect working indoor climate for both north and south-facing offices.

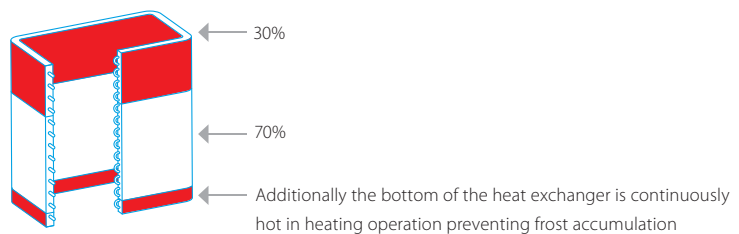
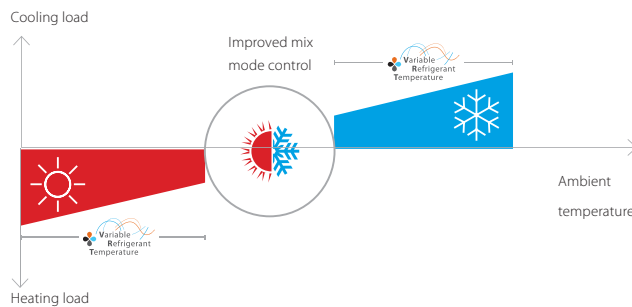

Wide heating operation range

VRV IV heat recovery has a standard operation range down to -20°C in heating. It can also provide cooling down to -20°C for technical server rooms (field setting).

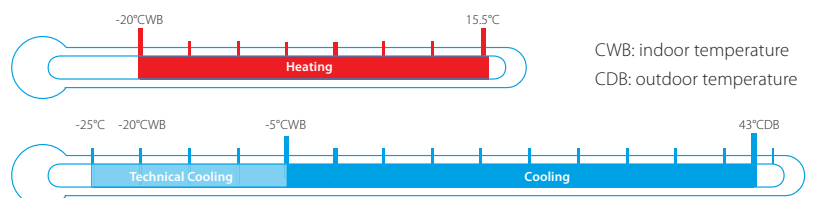

Advantages of 3-pipe technology

More “free” heat

Daikin 3-pipe technology needs less energy to recover heat, meaning significantly higher efficiency during heat recovery mode. Our system can recover heat at a low condensing temperature because it has dedicated gas, liquid and discharge pipes.

In a 2-pipe system, gas and liquid travel as a mixture so the condensing temperature needs to be higher in order to separate the mixed gas and liquid refrigerant. The higher condensing temperature means more energy is used to recover heat resulting in lower efficiency.

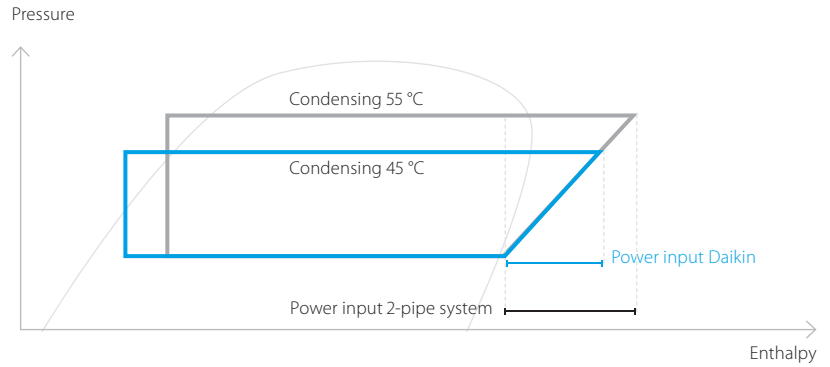

Lower pressure drop means more efficiency

- › Smooth refrigerant flow in 3-pipe system thanks to 2 smaller gas pipes results in higher energy efficiency
- › Disturbed refrigerant flow in large gas pipe on 2-pipe system results in bigger pressure drop

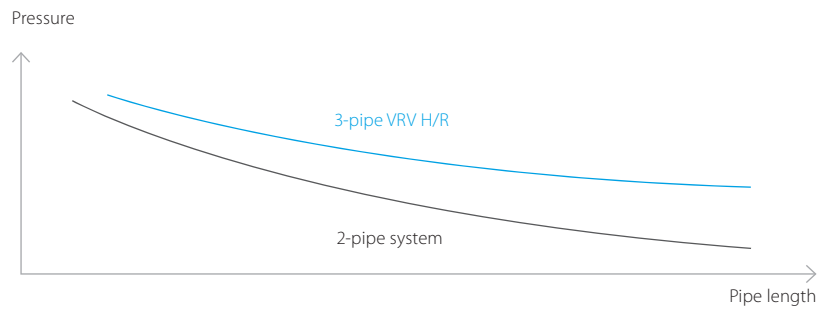

Freely combine outdoor units

Combine outdoor units flexibly to reduce your carbon footprint, optimise your system for continuous heating, and achieve the highest efficiency.

Flexible piping design

Total piping length	1000m
Longest length actual (Equivalent)	165m (190m)
Longest length after first branch	90m ¹
Level difference between indoor and outdoor units	90m ¹
Level difference between indoor units	30m

¹ Outdoor unit in highest position

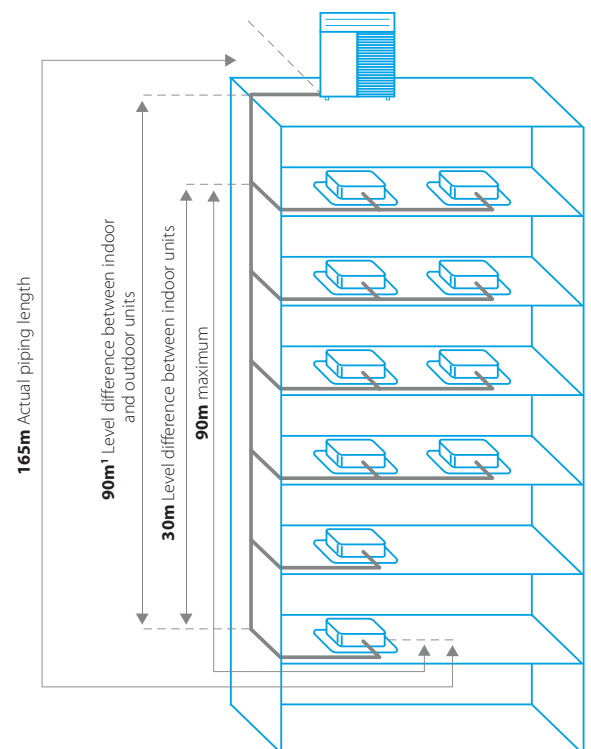

Fully redesigned BS boxes

Maximum design flexibility and installation speed

- › Quickly and flexibly design your system with a unique range of single and multi BS boxes.
- › A wide variety of compact and lightweight multi BS boxes greatly reduces installation time.
- › Free combination of single and multi BS boxes

Single port

- › Unique to the market
- › Compact and light to install
- › No drain piping needed
- › Ideal for remote rooms
- › Technical cooling function
- › Connect up to 250 class unit (28 kW)
- › Allows multi-tenant applications

Multi port: 4 – 6 – 8 – 10 – 12 – 16

- › Up to 55% smaller and 41% lighter than previous range
- › Faster installation thanks to a reduced number of brazing points and wiring
- › All indoor units connectable to one BS box
- › Fewer inspection ports needed
- › Up to 16 kW capacity available per port
- › Connect up to 250 class unit (28kW) by combining 2 ports
- › No limit on unused ports, permitting phased installation



Faster installation thanks to open connection

- › No need to cut the pipe before brazing – for indoor units smaller or equal to 5.6 kW (50 class)
- › Cut and braise the pipe – for indoor units bigger or equal to 7.1 kW (63 class)

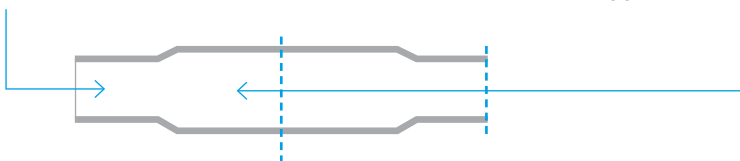

Maximum comfort at all times

With the VRV BS box, any indoor unit not being used to switch between heating and cooling maintains the constant desired temperature. This is because our heat recovery system does not need to equalise pressure over the entire system after a change-over.

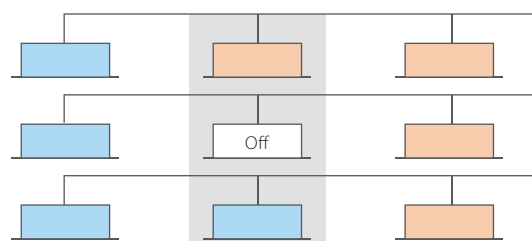

VRV IV heat recovery

Best efficiency & comfort solution

- › Fully integrated solution with heat recovery for maximum efficiency!
- › Covers all thermal needs of a building via a single point of contact: accurate temperature control, ventilation, hot water, air handling units and Biddle air curtains
- › “Free” heating and hot water through heat recovery
- › The perfect personal comfort for guests/tenants via simultaneous cooling and heating
- › Incorporates VRV IV standards & technologies: Variable Refrigerant Temperature, continuous heating, VRV configurator, 7 segment display and full inverter compressors, 4-side heat exchanger, refrigerant cooled PCB, new DC fan motor
- › Operation range down to -20°C for technical cooling operation such as server rooms
- › Contains all standard VRV features

Outdoor system				REYQ	8T	10T	12T	14T	16T	18T	20T	
Capacity range				HP	8	10	12	14	16	18	20	
Cooling capacity	Nom.			kW	22.4 (1) (2)	28.0 (1) (2)	33.5 (1) (2)	40.0 (1) (2)	45.0 (1) (2)	50.4	56.0	
Heating capacity	Nom.			kW	22.4 (3) (4)	28.0 (3) (4)	33.5 (3) (4)	40.0 (3) (4)	45.0 (3) (4)	50.4	56.0	
	Max.			kW	25.0	31.5	37.5	45.0	50.0	56.5	63.0	
Power input - 50Hz	Cooling	Nom.		kW	5.31 (1) / 4.56 (2)	7.15 (1) / 6.19 (2)	9.23 (1) / 8.31 (2)	10.7 (1) / 9.61 (2)	12.8 (1) / 11.9 (2)	15.2	18.6	
		Heating	Nom.	kW	4.75 (3) / 4.47 (3)	6.29 (3) / 5.47 (3)	8.05 (3) / 6.83 (3)	9.60 (3) / 9.37 (3)	11.2 (3) / 9.88 (3)	12.3	14.9	
		Max.		kW	5.51	7.38	9.43	11.3	12.9	14.3	17.5	
EER					4.22 (1) / 4.92 (2)	3.92 (1) / 4.52 (2)	3.63 (1) / 4.03 (2)	3.74 (1) / 4.16 (2)	3.52 (1) / 3.79 (2)	3.32	3.01	
COP - Max.					4.54	4.27	3.98		3.88	3.95	3.60	
COP - Nom.					4.72 (3) / 5.01 (3)	4.45 (3) / 5.12 (3)	4.16 (3) / 4.90 (3)	4.17 (3) / 4.27 (3)	4.02 (3) / 4.56 (3)	4.10	3.76	
ESEER					7.41	7.37	6.84	7.05	6.63	6.26	5.68	
Maximum number of connectable indoor units					64 (5)							
Indoor index connection	Min.				100	125	150	175	200	225	250	
	Nom.				200	250	300	350	400	450	500	
	Max.				260	325	390	455	520	585	650	
Dimensions	Unit	HeightxWidthxDepth		mm	1,685x930x765				1,685x1,240x765			
Weight	Unit			kg	210	218		304	305	337		
Fan	Air flow rate	Cooling	Nom.	m ³ /min	162	175	185	223	260	251	261	
Sound power level	Cooling	Nom.		dBA	78	79	81		86		88	
Sound pressure level	Cooling	Nom.		dBA	58		61		64	65	66	
		Night Quiet Mode	Level 1	dBA	56	58	58	58	58	60	60	
			Level 2	dBA	55	54	54	52	52	52	52	
			Level 3	dBA	53	52	52	47	47	48	48	
Operation range	Cooling	Min.~Max.		°CDB	-5.0~43.0							
	Heating	Min.~Max.		°CWB	-20~15.5							
Refrigerant	Type / GWP				R-410A / 2,087.5							
	Charge			kg/TCO ₂	9.7/20.2	9.8/20.5	9.9/20.7	11.8/24.6				
Piping connections	Liquid	OD		mm	9.52		12.7		15.9			
	Gas	OD		mm	19.1	22.2	28.6		28.6			
	Discharge gas	OD		mm	15.9		19.1		22.2		28.6	
	Total piping length	System	Actual	m	1,000							
Power supply	Phase/Frequency/Voltage			Hz/V	3N~/50/380-415							
Current - 50Hz	Maximum fuse amps (MFA)			A	20	25		32	40		50	

Outdoor system				REYQ	10T	13T	16T	18T	20T	22T	24T	26T	28T	30T	32T
System	Outdoor unit module 1				REMQ5T		REYQ8T		REYQ10T	REYQ8T	REYQ12T		REYQ16T		
	Outdoor unit module 2				REMQ5T	REYQ8T	REYQ10T	REYQ12T	REYQ16T	REYQ14T	REYQ16T	REYQ18T	REYQ18T	REYQ16T	
Capacity range				HP	10	13	16	18	20	22	24	26	28	30	32
Cooling capacity	Nom.			kW	28.0	36.4	44.8	50.4	55.9	61.5	67.4	73.5	78.5	83.9	90.0
Heating capacity	Nom.			kW	28.0	36.4	44.8	50.4	55.9	61.5	67.4	73.5	78.5	83.9	90.0
	Max.			kW	32.0	41.0	50.0	56.5	62.5	69.0	75.0	82.5	87.5	94.0	100.0
Power input - 50Hz	Cooling	Nom.		kW	6.34	8.48	10.62	12.46	14.54	16.38	18.11	19.93	22.03	24.43	25.6
		Heating	Nom.	kW	5.42	7.46	9.50	11.04	12.80	14.34	15.95	17.65	19.25	20.35	22.4
		Max.		kW	6.50	8.76	11.02	12.89	14.94	16.81	18.41	20.73	22.33	23.73	25.8
EER					4.42	4.29	4.22	4.04	3.84	3.75	3.72	3.69	3.56	3.43	3.52
COP - Max.					4.92	4.68	4.54	4.38	4.18	4.10	4.07	3.98	3.92	3.96	3.88
COP - Nom.					5.17	4.88	4.72	4.57	4.37	4.29	4.23	4.16	4.08	4.12	4.02
ESEER - Automatic					7.77	7.54	7.41	7.38	7.06	7.07	6.87	6.95	6.72	6.48	6.63
ESEER - Standard					6.55	6.36	6.25	5.98	5.68	5.54	5.46	5.41	5.23	5.03	5.14
Maximum number of connectable indoor units					64										
Indoor index connection	Min.				125	162.5	200	225	250	275	300	325	350	375	400
	Nom.				250	325.0	400	450	500	550	600	650	700	750	800
	Max.				325	422.5	520	585	650	715	780	845	910	975	1,040
Piping connections	Liquid	OD		mm	9.52	12.7		15.9			19.1				
	Gas	OD		mm	22.2	28.6						34.9			
	Discharge gas	OD		mm	19.1		22.2		28.6						
	Total piping length	System	Actual	m	500				1,000						
Current - 50Hz	Maximum fuse amps (MFA)			A	40				50	63				80	
Continuous heating					v										



Outdoor system				REYQ	34T	36T	38T	40T	42T	44T	46T	48T	50T	52T	54T
System	Outdoor unit module 1				REYQ16T		REYQ8T	REYQ10T		REYQ12T	REYQ14T	REYQ16T			REYQ18T
	Outdoor unit module 2				REYQ18T	REYQ20T	REYQ12T		REYQ16T				REYQ18T		
	Outdoor unit module 3				-		REYQ18T		REYQ16T				REYQ18T		
Capacity range			HP	34	36	38	40	42	44	46	48	50	52	54	
Cooling capacity	Nom.		kW	95.4	101.0	106.3	111.9	118.0	123.5	130.0	135.0	140.4	145.8	151.2	
Heating capacity	Nom.		kW	95.4	101.0	106.3	111.9	118.0	123.5	130.0	135.0	140.4	145.8	151.2	
	Max.		kW	106.5	113.0	119.0	125.5	131.5	137.5	145.0	150.0	156.5	163.0	169.5	
Power input - 50Hz	Cooling	Nom.	kW	28.0	31.4	29.74	31.58	32.75	34.83	36.3	38.4	40.8	43.2	45.6	
		Heating	Nom.	kW	23.5	26.1	25.10	26.64	28.69	30.45	32.00	33.6	34.7	35.8	36.9
		Max.	kW	27.2	30.4	29.24	31.11	33.18	35.23	37.1	38.7	40.1	41.5	42.9	
EER				3.41	3.22	3.57	3.54	3.60	3.55	3.58	3.52	3.44	3.38	3.32	
COP - Max.				3.92	3.72	4.07	4.03	3.96	3.90	3.91	3.88	3.90	3.93	3.95	
COP - Nom.				4.06	3.87	4.24	4.20	4.11	4.06	4.02	4.05	4.07	4.10		
ESEER - Automatic				6.43	6.06	6.66	6.68	6.79	6.68	6.75	6.63	6.49	6.37	6.26	
ESEER - Standard				4.97	4.70	5.25	5.20	5.28	5.20	5.23	5.14	5.03	4.93	4.84	
Maximum number of connectable indoor units					64										
Indoor index connection	Min.			425	450	475	500	525	550	575	600	625	650	675	
	Nom.			850	900	950	1,000	1,050	1,100	1,150	1,200	1,250	1,300	1,350	
	Max.			1,105	1,170	1,235	1,300	1,365	1,430	1,495	1,560	1,625	1,690	1,755	
Piping connections	Liquid	OD	mm	19.1											
		Gas	OD	mm	34.9	41.3									
	Discharge gas	OD	mm	28.6		34.9									
		Total piping length	System	Actual	-			1,000							
Current - 50Hz	Maximum fuse amps (MFA)			A	80			100			125				
Continuous heating					v										
Outdoor unit module				REMQ	5T										
Dimensions	Unit	HeightxWidthxDepth		mm	1,685x930x765										
Weight	Unit			kg	210										
Fan	Air flow rate	Cooling	Nom.	m ³ /min	162										
Sound power level	Cooling	Nom.		dB(A)	77										
Sound pressure level	Cooling	Nom.		dB(A)	56										
Operation range	Cooling	Min.-Max.		°CDB	-5.0~43.0										
	Heating	Min.-Max.		°CWB	-20~15.5										
Refrigerant	Type / GWP				R-410A / 2,087.5										
	Charge			kg/TCO,Eq	9.7/20.2										
Power supply	Phase/Frequency/Voltage			Hz/V	3N~/50/380-415										
Current - 50Hz	Maximum fuse amps (MFA)			A	20										

(1) Nominal cooling capacities are based on: indoor temperature: 27°CDB, 19°CWB, outdoor temperature: 35°CDB, equivalent refrigerant piping: 5m, level difference: 0m. Data for standard efficiency series. (2) Nominal cooling capacities are based on: indoor temperature: 27°CDB, 19°CWB, outdoor temperature: 35°CDB, equivalent refrigerant piping: 5m, level difference: 0m. Data for high efficiency series, Eurovent certified. (3) Nominal heating capacities are based on: indoor temperature: 20°CDB, outdoor temperature: 7°CDB, 6°CWB, equivalent refrigerant piping: 5m, level difference: 0m. Data for standard efficiency series. (4) Nominal heating capacities are based on: indoor temperature: 20°CDB, outdoor temperature: 7°CDB, 6°CWB, equivalent refrigerant piping: 5m, level difference: 0m. Data for high efficiency series, Eurovent certified. (5) Actual number of connectable indoor units depends on the indoor unit type (VRV indoor, Hydrobox, RA indoor, etc) and the connection ratio restriction for the system (50% <= CR <= 130%)

REM05T / REY08-12T

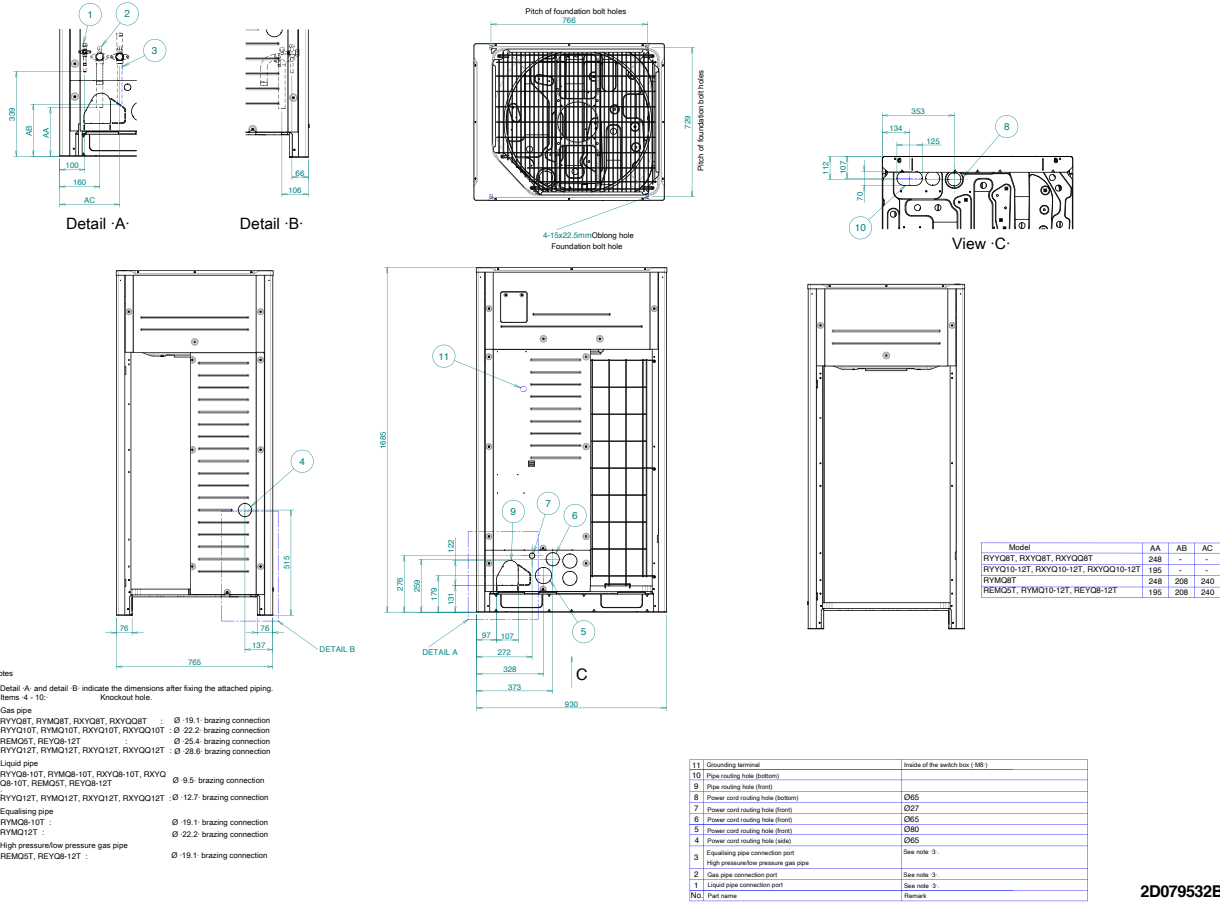

2D079532B

REYQ14-20T

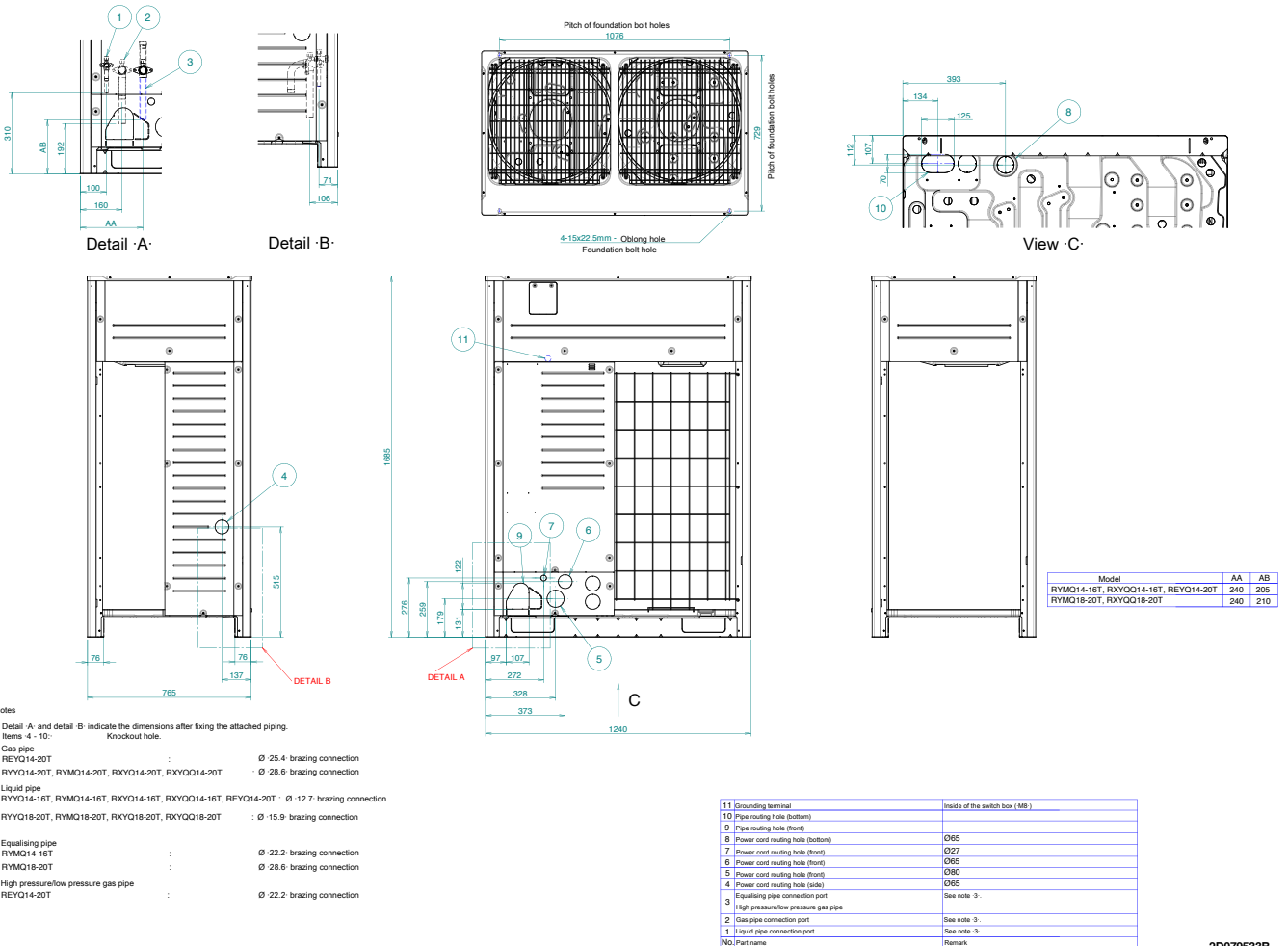

2D079533B

REYQ-T

For single unit installation

For installation in rows

For centralized group layout

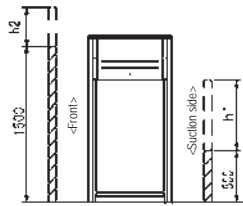
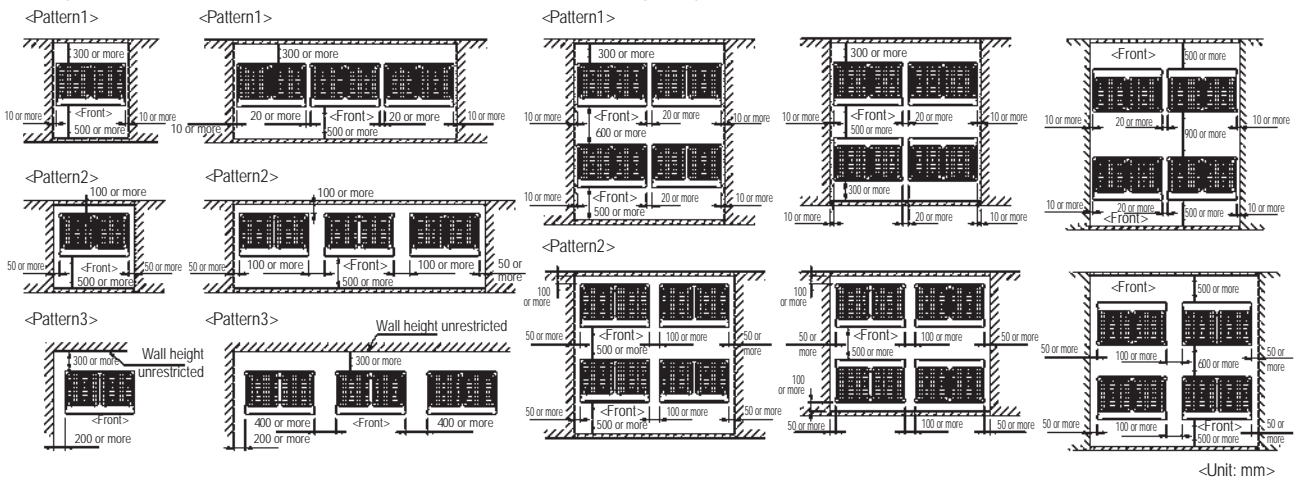

NOTES

- Heights of walls in case of Patterns 1 and 2:
 Front: 1500mm
 Suction side: 500mm
 Side: Height unrestricted
 Installation space as shown on this drawing is based on the cooling operation at 35 degrees outdoor air temperature.
 When the design outdoor air temperature exceeds 35 degrees or the load exceeds maximum ability because of much generation load of heat in all outdoor units, take the suction side space more broadly than the space as shown in this drawing.
- If the above wall heights are exceeded then $h/2$ and $h/2$ should be added to the front and suction side service space respectively as shown in the figure on the right.
- When installing the units most appropriate pattern should be selected from those shown above in order to obtain the best fit in the space available always bearing in mind the need to leave enough space for a person to pass between units and wall and for the air to circulate freely. (If more units are to be installed than are catered for in the above patterns your layout should take account of the possibility of short circuits.)
- The units should be installed to leave sufficient space at the front for the on site refrigerant piping work to be carried out comfortably.

Individual branch selector for VRV IV heat recovery

- › Unique range of single and multi BS boxes for flexible and fast design
- › Compact & light to install
- › Ideal for remote rooms as no drain piping is needed
- › Allows integration of server rooms into the heat recovery solution thanks to technical cooling function
- › Connect up to 250 class unit (28kW)
- › Faster installation thanks to open connection
- › Allows multi tenant applications
- › Connectable to REYQ-T VRV IV heat recovery units



BS1Q-A

Indoor unit				BS	1Q10A	1Q16A	1Q25A
Power input	Cooling	Nom.		kW		0.005	
	Heating	Nom.		kW		0.005	
Maximum number of connectable indoor units					5		8
Maximum capacity index of connectable indoor units					15 < x ≤ 100	100 < x ≤ 160	160 < x ≤ 250
Dimensions	Unit	HeightxWidthxDepth		mm	207x388x326		
Weight	Unit			kg	12		15
Casing	Material				Galvanised steel plate		
Piping connections	Outdoor unit	Liquid	Type/OD	mm	Braze connection/9.5		
		Gas	Type/OD	mm	Braze connection/15.9		Braze connection/22.2
		Discharge gas	Type/OD	mm	Braze connection/12.7		Braze connection/19.1
	Indoor unit	Liquid	Type/OD	mm	Braze connection/9.5		
		Gas	Type/OD	mm	Braze connection/15.9		Braze connection/22.2
Sound absorbing thermal insulation					Foamed polyurethane Flame-resistant needle felt		
Power supply	Phase/Frequency/Voltage			Hz/V	1~/50/220-240		
Total circuit	Maximum fuse amps (MFA)			A	15		

BS-Q14A

Multi branch selector for VRV IV heat recovery

- › Unique range of single and multi BS boxes for flexible and fast design
- › Major reduction in installation time thanks to wide range, compact size and light weight multi BS boxes
- › Up to 70% smaller and 66% lighter than previous series
- › Faster installation thanks to a reduced number of brazing points and wiring
- › All indoor units connectable to one BS box
- › Less inspection ports needed compared to installing single BS boxes
- › Up to 16kW capacity available per port
- › Connect up to 250 class unit (28kW) by combining 2 ports
- › No limit on unused ports allowing phased installation
- › Faster installation thanks to open connection
- › Connectable to REYQ-T VRV IV heat recovery units



BS6,8Q14A

Indoor unit				BS	4Q14A	6Q14A	8Q14A	10Q14A	12Q14A	16Q14A
Power input	Cooling	Nom.		kW	0.043	0.064	0.086	0.107	0.129	0.172
	Heating	Nom.		kW	0.043	0.064	0.086	0.107	0.129	0.172
Maximum number of connectable indoor units					20	30	40	50	60	64
Maximum number of connectable indoor units per branch					5					
Number of branches					4	6	8	10	12	16
Maximum capacity index of connectable indoor units					400	600	750			
Maximum capacity index of connectable indoor units per branch					140					
Dimensions	Unit	HeightxWidthxDepth		mm	298x370x430	298x580x430		298x820x430		298x1,060x430
Weight	Unit			kg	17	24	26	35	38	50
Casing	Material				Galvanised steel plate					
Piping connections	Outdoor unit	Liquid	OD	mm	9.5	12.7	12.7 / 15.9	15.9	15.9 / 19.1	19.1
		Gas	OD	mm	22.2 / 19.1	28.6 / 22.2	28.6	28.6 / 34.9		34.9
		Discharge gas	OD	mm	19.1 / 15.9	19.1 / 22.2	19.1 / 22.2 / 28.6	28.6		
	Indoor unit	Liquid	OD	mm	9.5 / 6.4					
		Gas	OD	mm	15.9 / 12.7					
		Drain			VP20 (I.D. 20/O.D. 26)					
Sound absorbing thermal insulation					Urethane foam, polyethylene foam					
Power supply	Phase/Frequency/Voltage			Hz/V	1~/50/220-440					
Total circuit	Maximum fuse amps (MFA)			A	15					

Individual branch selector for VRV heat recovery

- › Allows individual cool / heat switching of 1 group of indoor units
- › Maximum design flexibility because individual and multi boxes can be combined in one system
- › Low built-in height
- › No drain piping needed
- › Allows multi tenant applications (option PCB required)
- › Connectable to VRV W-IV series (RWEYQ-T)



BSVQ-P9B

Indoor unit			BSVQ	100P9B	160P9B	250P9B
Power input	Cooling	Nom.	kW	0.005		
	Heating	Nom.	kW	0.005		
Maximum number of connectable indoor units				6	8	
Maximum capacity index of connectable indoor units				15 < x ≤ 100	100 < x ≤ 160	160 < x ≤ 250
Dimensions	Unit	HeightxWidthxDepth	mm	207x388x326		
Weight	Unit		kg	12		15
Casing	Material	Galvanised steel plate				
Piping connections	Outdoor unit	Liquid	Type/OD	Braze connection/9.5		
		Gas	Type/OD	Braze connection/15.9		
		Discharge gas	Type/OD	Braze connection/12.7	Braze connection/12.7	Braze connection/19.1
	Indoor unit	Liquid	Type/OD	Braze connection/9.5		
		Gas	Type/OD	Braze connection/15.9	Braze connection/15.9	Braze connection/22.2
				Foamed polyurethane Flame-resistant needle felt		
Sound absorbing thermal insulation						
Power supply	Phase/Frequency/Voltage		Hz/V	1~/50/220-240		
Total circuit	Maximum fuse amps (MFA)		A	15		

BSV4Q-PV/BSV6Q-PV

Multi branch selector for VRV heat recovery

- › Faster installation thanks to a reduced number of brazing points and wiring
- › Allows individual cool / heat switching for up to 4 or 6 groups of indoor units
- › Maximum design flexibility because individual and multi boxes can be combined in one system
- › Low built-in height
- › No drain piping needed
- › Connectable to VRV W-IV series (RWEYQ-T)

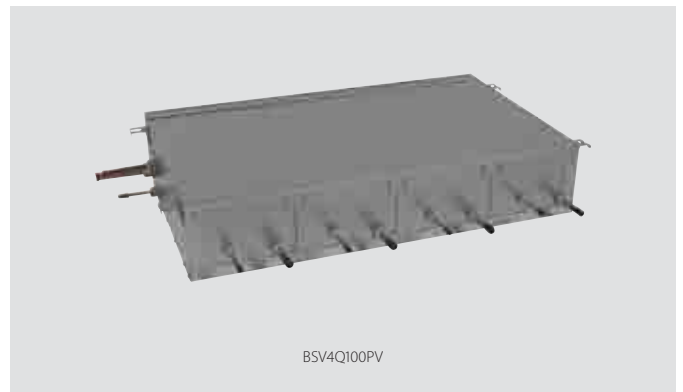

BSV4Q100PV

Indoor unit			BSV4Q-PV/BSV6Q-PV	4Q100PV	6Q100PV	
Power input	Cooling	Nom.	kW	0.020	0.030	
	Heating	Nom.	kW	0.020	0.030	
Maximum number of connectable indoor units				24	36	
Maximum number of connectable indoor units per branch				6		
Number of branches				4	6	
Maximum capacity index of connectable indoor units				400	600	
Maximum capacity index of connectable indoor units per branch				100		
Dimensions	Unit	HeightxWidthxDepth	mm	209x1,053x635	209x1,577x635	
Weight	Unit		kg	60	89	
Casing	Material	Galvanised steel plate				
Piping connections	Outdoor unit	Liquid	Type/OD	Braze connection/12.7		
		Gas	Type/OD	Braze connection/28.6		
		Discharge gas	Type/OD	Braze connection/19.1	Braze connection/28.6	
	Indoor unit	Liquid	Type/OD	Braze connection/9.5		
		Gas	Type/OD	Braze connection/15.9		
				Foamed polyurethane Flame-resistant needle felt		
Sound absorbing thermal insulation						
Power supply	Phase/Frequency/Voltage		Hz/V	1~/50/220-240		
Total circuit	Maximum fuse amps (MFA)		A	15		

VRV IV heat pump

Daikin's optimum solution
with top comfort

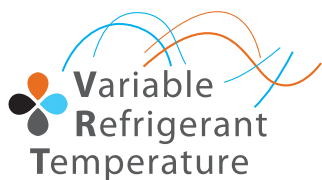

VRV IV standards:

Variable refrigerant temperature

Customize your VRV for best seasonal efficiency & comfort

Continuous heating

The new standard in heating comfort

VRV configurator

Software for simplified commissioning, configuration and customisation

- > 7 segment indicator
- > Automatic refrigerant charge
- > Refrigerant containment check
- > Night quiet mode
- > Low noise function
- > Full inverter compressors
- > Gas cooled PCB
- > 4 side heat exchanger
- > Reluctance brushless DC compressor
- > Sine wave DC inverter
- > DC fan motor
- > E-pass heat exchanger
- > I demand function

For detailed explanation of these functions refer to vrv iv technologies tab



Wide range of indoor units

Combine VRV indoor units with stylish indoor units (Daikin Emura, Nexura, ...)



Connectable indoor units

	15 CLASS	20 CLASS	25 CLASS	35 CLASS	42 CLASS	50 CLASS	60 CLASS	71 CLASS
Daikin Emura – Wall mounted unit		FTXG20LW FTXG20LS	FTXG25LW FTXG25LS	FTXG35LW FTXG35LS		FTXG50LW FTXG50LS		
Wall mounted unit	CTXS15K	FTXS20K	FTXS25K	FTXS35K CTXS35K	FTXS42K	FTXS50K	FTXS60G	FTXS71G
Nexura – Floor standing unit			FVXG25K	FVXG35K		FVXG50K		
Floor standing unit			FVXS25F	FVXS35F		FVXS50F		
Flexi type unit			FLXS25B	FLXS35B9		FLXS50B	FLXS60B	

BPMKS box needed to connect RA indoors to VRV IV (RYYQ-T and RXYQ-T(9))

VRV IV

proven in practice: 40% more efficient

A field trial at a German fashion chain store demonstrated how the innovative features of VRV IV have improved energy efficiency dramatically over previous models.

Results: up to 60% less energy consumed

The results of the trial showed that the new VRV IV system consumed much less energy, particularly when cooling, compared with the VRV III system – in some cases up to 60% less. When heating, savings were an average of 20%.

The Unterhaching trial demonstrates how VRV IV heat pump technology uses a renewable energy source – air – to provide a complete and environmentally sustainable solution for heating, cooling, and ventilation in commercial environments. The trial also shows that businesses can only identify and control energy wastage through careful and intelligent monitoring of climate control systems, a service which Daikin can offer.

Average daily consumption during working hours in kWh

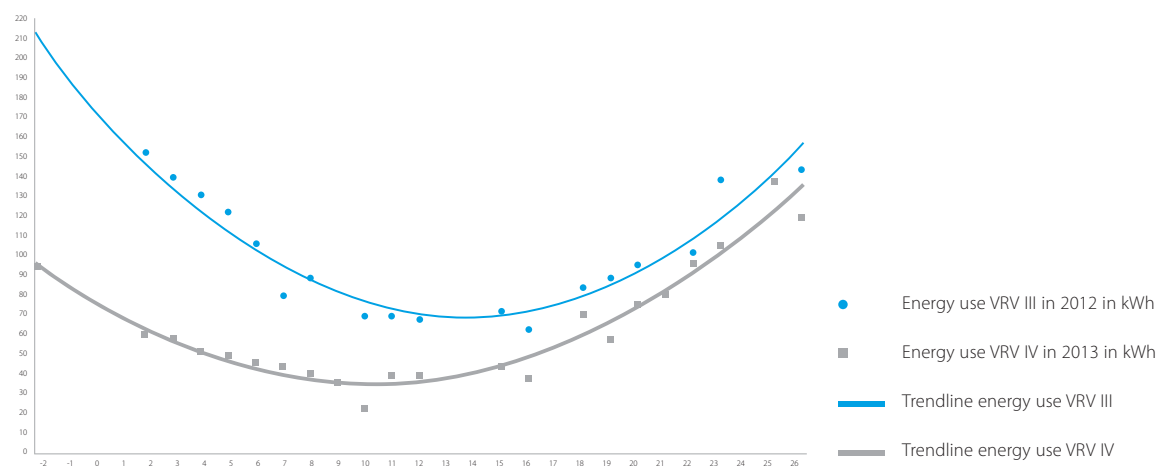

	VRV III 20HP (2 modules)	VRV IV 18HP (1 module)
Period	March 2012 - February 2013	March 2013 - February 2014
Avg (kWh/Month)	2.797	1.502
Total (KWh)	33.562	18.023
Total (€)	6.041	3.244
Yearly (operation cost/m² (€/m²))	9,9	5,3
46% savings = € 2.797		

Measured data

Fashion store Unterhaching (Germany)

- › Floor space: 607m²
- › Energy cost: 0,18 €/kWh
- › System taken into account for consumption:
 - VRV IV heat pump with continuous heating
 - Round flow cassettes (without auto cleaning panel)
 - VAM for ventilation (2x VAM2000)
 - Biddle Air curtain.



Free combination of outdoor units

Freely combine outdoor units to optimise for small footprint, continuous heating, highest efficiency or any other combination

Flexible piping design

Total piping length	1000m
Longest length actual (Equivalent)	165m (190m)
Longest length after first branch	90m ¹
Level difference between indoor and outdoor units	90m ¹
Level difference between indoor units	30m

¹ Contact your local dealer for more information and restrictions
² in case outdoor unit is located below indoor units

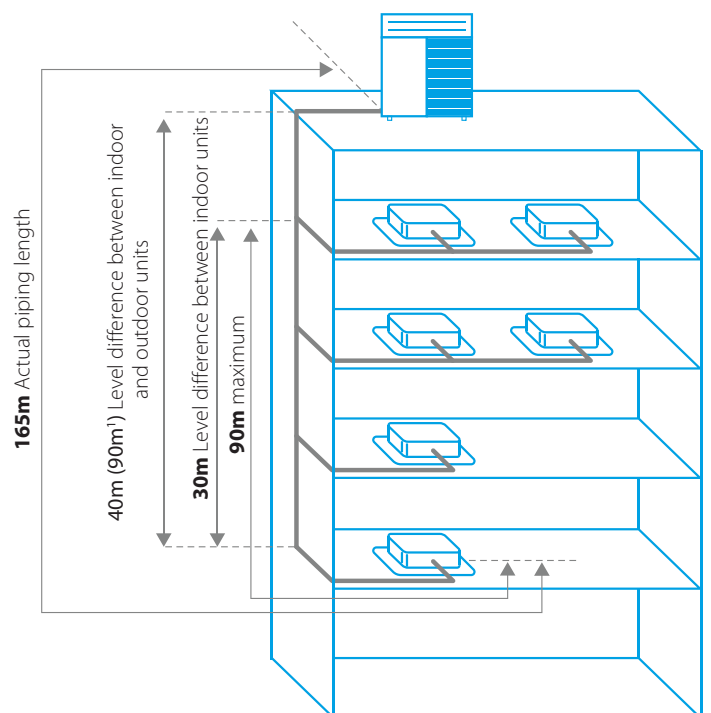

VRV IV heat pump

Daikin's optimum solution with top comfort

- › Covers all thermal needs of a building via a single point of contact: accurate temperature control, ventilation, hot water, air handling units and Biddle air curtains
- › Wide range of indoor units: possibility to combine VRV with stylish indoor units (Daikin Emura, Nexura, ...)
- › Incorporates VRV IV standards & technologies: Variable Refrigerant Temperature, continuous heating, VRV configurator, 7 segment display and full inverter compressors, 4-side heat exchanger, refrigerant cooled PCB, new DC fan motor
- › Available as heating only by irreversible field setting
- › Contains all standard VRV features

Outdoor system		RYYQ/RXYQ	8T/8T9	10T	12T	14T	16T	18T	20T		
Capacity range		HP	8	10	12	14	16	18	20		
Cooling capacity	Nom.	kW	22.4 (1) / 22.4 (2)	28.0 (1) / 28.0 (2)	33.5 (1) / 33.5 (2)	40.0 (1) / 40.0 (2)	45.0 (1) / 45.0 (2)	50.4 (1)	56.0 (1)		
Heating capacity	Nom.	kW	22.4 (3) / 22.40 (4)	28.0 (3) / 28.00 (4)	33.5 (3) / 33.50 (4)	40.0 (3) / 40.0 (4)	45.0 (3) / 45.0 (4)	50.4 (3)	56.0 (3)		
	Max.	kW	25.0 (3)	31.5 (3)	37.5 (3)	45.0 (3)	50.0 (3)	56.5 (3)	63.0 (3)		
Power input - 50Hz	Cooling	Nom.	kW	5.21 (1) / 4.47 (2)	7.29 (1) / 6.32 (2)	8.98 (1) / 8.09 (2)	11.0 (1) / 9.88 (2)	13.0 (1) / 12.10 (2)	15.0 (1)	18.5 (1)	
		Nom.	kW	4.75 (3) / 4.47 (4)	6.29 (3) / 5.47 (4)	7.77 (3) / 6.59 (4)	9.52 (3) / 9.30 (4)	11.1 (3) / 9.8 (4)	12.6 (3)	14.5 (3)	
	Heating	Max.	kW	5.51 (3)	7.38 (3)	9.10 (3)	11.2 (3)	12.8 (3)	14.6 (3)	17.0 (3)	
EER			4.30 (1) / 5.01 (2)	3.84 (1) / 4.43 (2)	3.73 (1) / 4.14 (2)	3.64 (1) / 4.05 (2)	3.46 (1) / 3.73 (2)	3.36 (1)	3.03 (1)		
ESEER - Automatic			7.53	7.20	6.96	6.83	6.50	6.38	5.67		
ESEER - Standard			6.37	5.67	5.50	5.31	5.05	4.97	4.42		
COP - Max.			4.54 (3)	4.27 (3)	4.12 (3)	4.02 (3)	3.91 (3)	3.87	3.71		
COP - Nom.			4.72 (3) / 5.01 (4)	4.45 (3) / 5.12 (4)	4.31 (3) / 5.08 (4)	4.20 (3) / 4.30 (4)	4.05 (3) / 4.59 (4)	4.00	3.86		
Maximum number of connectable indoor units			64 (5)								
Indoor index connection		Min./Nom./Max.	100/200/260	125/250/325	150/300/390	175/350/455	200/400/520	225/450/585	250/500/650		
Dimensions	Unit	HeightxWidthxDepth	mm			1,685x930x765					
Weight	Unit		kg	243	252	356	391				
Fan	Air flow rate	Cooling	Nom.	m ³ /min	162	175	185	223	260	251	261
Sound power level	Cooling	Nom.	dB(A)	78	79	81	86				
Sound pressure level	Cooling	Nom.	dB(A)	58		61	64	65	66		
Operation range	Cooling	Min.~Max.	°CDB	-5~43							
	Heating	Min.~Max.	°CWB	-20~15.5							
Refrigerant	Type		R-410A								
	Charge		kg	5.9	6	6.3	10.3	10.4	11.7	11.8	
			tCO ₂ eq	12.3	12.5	13.2	21.5	21.7	24.4	24.6	
Piping connections	Liquid	OD	mm	9.52		12.7		15.9			
	Gas	OD	mm	19.1	22.2	28.6					
	Total piping length	System	Actual	m							1,000
Power supply	Phase/Frequency/Voltage		Hz/V							3N~/50/380-415	
Current - 50Hz	Maximum fuse amps (MFA)	A	20	25	32	40	50				

Outdoor system		RYYQ/RXYQ	22T	24T/24T9	26T	28T	30T	32T	34T	36T	38T/38T9	
System	Outdoor unit module 1		10T	8T		12T			16T		8T	
	Outdoor unit module 2		12T	16T	14T	16T	18T	16T	18T	20T	10T	
	Outdoor unit module 3										20T	
Capacity range		HP	22	24	26	28	30	32	34	36	38	
Cooling capacity	Nom.	kW	61.5	67.4	73.5	78.5	83.9	90.0	95.4	101.0	106.3	
Heating capacity	Nom.	kW	61.5	67.4	73.5	78.5	83.9	90.0	95.4	101.0	106.3	
	Max.	kW	69.0	75.0	82.5	87.5	94.0	100.0	106.5	113.0	119.0	
Power input - 50Hz	Cooling	Nom.	kW	16.27	18.2	20.0	22.0	24.0	26.0	28.0	31.5	29.2
		Nom.	kW	14.06	15.85	17.29	18.87	20.4	22.2	23.7	25.6	25.1
	Heating	Max.	kW	16.48	18.31	20.30	21.90	23.7	25.6	27.4	29.8	29.2
EER			3.77	3.70	3.68	3.57	3.5	3.46	3.4	3.21	3.6	
ESEER - Automatic			7.07	6.81	6.89	6.69	6.60	6.50	6.44	6.02	6.36	
ESEER - Standard			5.58	5.42	5.39	5.23	5.17	5.05	5.01	4.68	5.03	
COP - Max.			4.19	4.10	4.06	4.00	3.91	3.9	3.79	4.1		
COP - Nom.			4.37	4.25	4.16	4.1	4.05	4.0	3.95	4.2		
Maximum number of connectable indoor units			64									
Indoor index connection		Min./Nom./Max.	275/550/715	300/600/780	325/650/845	350/700/910	375/750/975	400/800/1,040	425/850/1,105	450/900/1,170	475/950/1,235	
Piping connections	Liquid	OD	mm	15.9								
	Gas	OD	mm	28.6	34.9				19.1		41.3	
	Total piping length	System	Actual	m							1,000	
Current - 50Hz	Maximum fuse amps (MFA)	A	63				80		100			



RYYQ8-12T
RXYQ8-12T(9)

Outdoor system		RYYQ/RXYQ	40T	42T	44T	46T	48T	50T	52T	54T	
System	Outdoor unit module 1		10T			12T	14T	16T		18T	
	Outdoor unit module 2		12T	16T				18T			
	Outdoor unit module 3		18T	16T				18T			
Capacity range		HP	40	42	44	46	48	50	52	54	
Cooling capacity	Nom.	kW	111.9	118.0	123.5	130.0	135.0	140.0	145.8	151.2	
	Max.	kW	125.5	131.5	137.5	145.0	150.0	156.0	163.0	169.5	
Heating capacity	Nom.	kW	111.9	118.0	123.5	130.0	135.0	140.0	145.8	151.2	
	Max.	kW	125.5	131.5	137.5	145.0	150.0	156.0	163.0	169.5	
	Power input - 50Hz	Cooling	Nom.	kW	31.3	33.3	35.0	37.0	39.0	40.7	43.0
	Heating	Nom.	kW	26.7	28.49	29.97	31.72	33.3	34.6	36.3	37.8
		Max.	kW	31.1	32.98	34.70	36.8	38.4	40.0	42.0	43.8
EER			3.6	3.54		3.51	3.46	3.44	3.4	3.40	
ESEER - Automatic			6.74	6.65	6.62	6.60	6.50	6.46	6.42	6.38	
ESEER - Standard			5.29	5.19	5.17	5.13	5.05	5.02	4.99	4.97	
COP - Max.			4.0	3.99	3.96	3.94	3.91	3.90			
COP - Nom.			4.2	4.14	4.12	4.10	4.05		4.0		
Maximum number of connectable indoor units			64								
Indoor index connection	Min./Nom./Max.		500/1,000/1,300	525/1,050/1,365	550/1,100/1,430	575/1,150/1,495	600/1,200/1,560	625/1,250/1,625	650/1,300/1,690	675/1,350/1,755	
Piping connections	Liquid	OD	mm		19.1						
	Gas	OD	mm		41.3						
	Total piping length	System	Actual	m		1,000					
Current - 50Hz	Maximum fuse amps (MFA)	A	100				125				

Outdoor unit module for RYYQ combinations		RYMQ	8T	10T	12T	14T	16T	18T	20T		
Dimensions	Unit	Height/Width/Depth	1,685/930/765				1,685/1,240/765				
Weight	Unit	kg	188	195		309		319			
Fan	Air flow rate	Cooling	Nom.	m ³ /min	162	175	185	223	260	251	261
Sound power level	Cooling	Nom.	dBA		78	79	81		86		88
Sound pressure level	Cooling	Nom.	dBA		58		61		64	65	66
Operation range	Cooling	Min.~Max.	°CDB		-5~43						
	Heating	Min.~Max.	°CWB		-20~15.5						
Refrigerant	Type	R-410A									
	Charge	kg	5.9	6	6.3	10.3	10.4	11.7	11.8		
		tCO ₂ eq	12.3	12.5	13.2	21.5	21.7	24.4	24.6		
	GWP	2,087.5									
Power supply	Phase/Frequency/Voltage	Hz/V	3N~/50/380-415								
Current - 50Hz	Maximum fuse amps (MFA)	A	20	25	32		40		50		

(1) Nominal cooling capacities are based on: indoor temperature: 27°CDB, 19°CWB, outdoor temperature: 35°CDB, equivalent refrigerant piping: 5m, level difference: 0m. Data for standard efficiency series (2) Nominal heating capacities are based on: indoor temperature: 20°CDB, outdoor temperature: 7°CDB, 6°CWB, equivalent refrigerant piping: 5m, level difference: 0m. Data for high efficiency series (3) Nominal heating capacities are based on: indoor temperature: 20°CDB, outdoor temperature: 7°CDB, 6°CWB, equivalent refrigerant piping: 5m, level difference: 0m. Data for standard efficiency series (4) Nominal cooling capacities are based on: indoor temperature: 27°CDB, 19°CWB, outdoor temperature: 35°CDB, equivalent refrigerant piping: 5m, level difference: 0m. Data for high efficiency series, Eurovent certified (5) Actual number of connectable indoor units depends on the indoor unit type (VRV indoor, Hydrobox, RA indoor, etc.) and the connection ratio restriction for the system (50% <= CR <= 130%) | The STANDARD ESEER value corresponds with normal VRV4 Heat Pump operation, not taking into account advanced energy saving operation functionality | The AUTOMATIC SEER value corresponds with normal VRV4 Heat Pump operation, taking into account advanced energy saving operation functionality (variable refrigerant temperature control operation)

RYYQ8-12T / RYMQ8-12T / RXYQ8-12T(9)

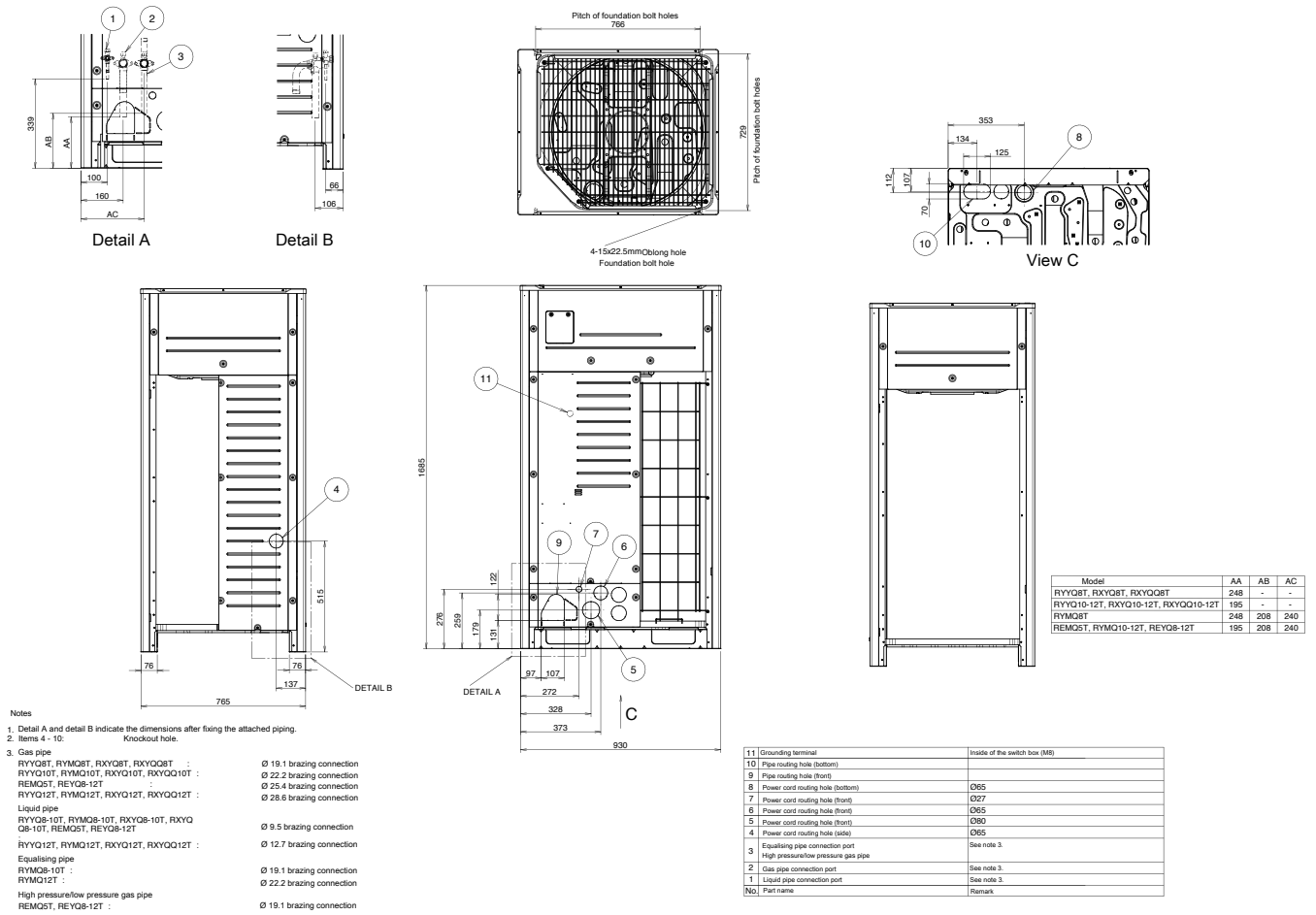

2D079532B

RYYQ14-20T / RYMQ14-20T / RXYQ14-20T

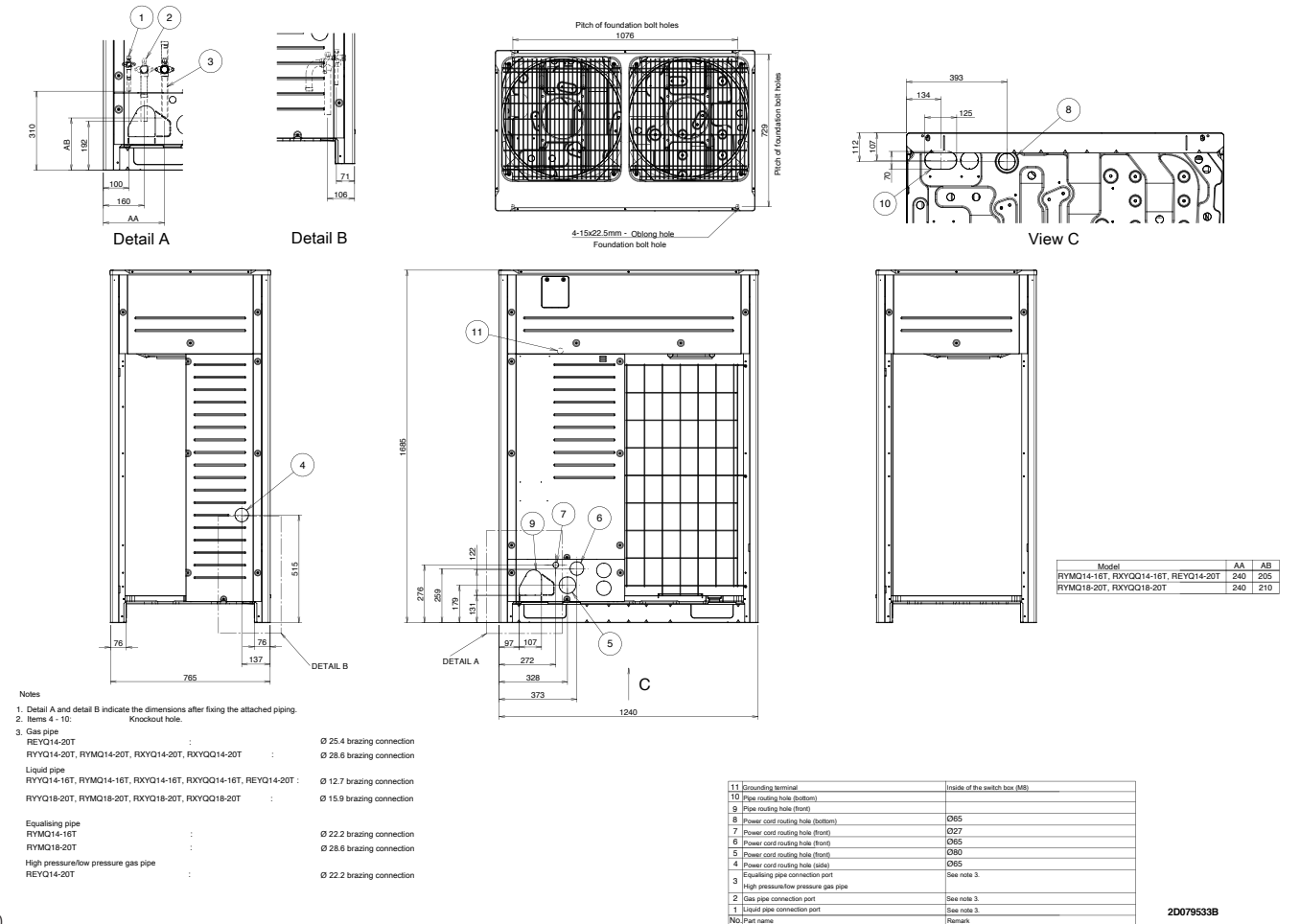

2D079533B

RYYQ-T / RXYQ-T(9)

For single unit installation

For installation in rows

For centralized group layout

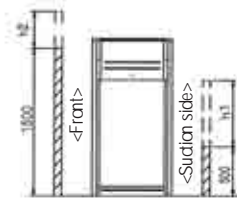
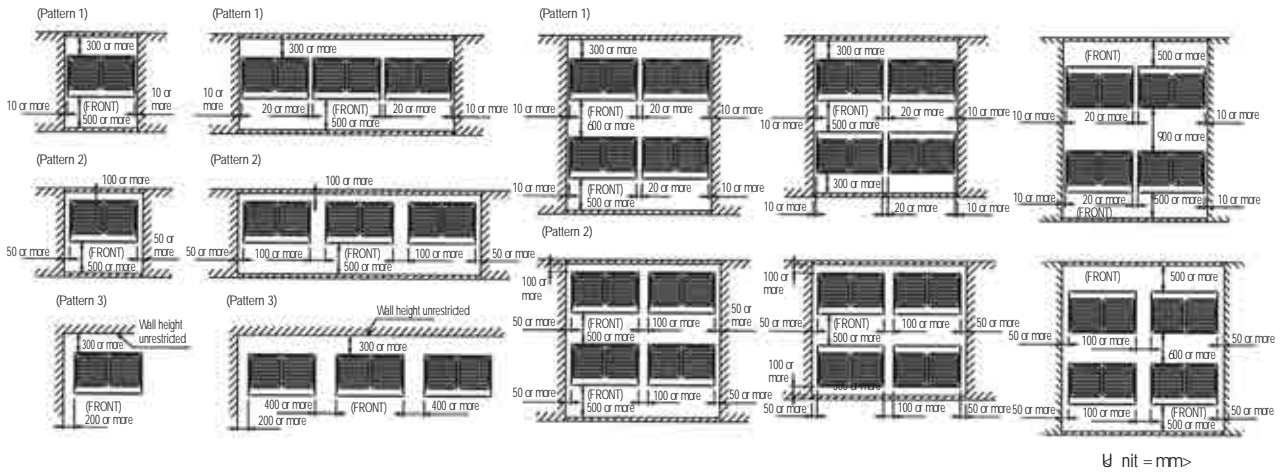

NOTES

- Heights of walls in case of patterns 1 and 2:
Front: 1500mm
Suction side: 500mm
Side: Height unrestricted
Installation space as shown on this drawing is based on the cooling operation at 35 degrees outdoor air temperature.
When the design outdoor air temperature exceeds 35 degrees or the load exceeds maximum ability of much generation load of heat in all outdoor unit, take the suction side space more broadly than the space as shown on this drawing.
- If the above wall heights are exceeded then $h2/2$ and $h1/2$ should be added to the front and suction side service spaces respectively as shown in the figure on the right.
- When installing the units most appropriate pattern should be selected from those shown above in order to obtain the best fit in the space available. Always keep in mind the need to leave enough space for a person to pass between units and wall and also for the air to circulate freely.
(If more units are to be installed than are catered for in the above patterns your layout should take account of the possibility of short circuits).
- The units should be installed to leave sufficient space at the front for the on site refrigerant piping work to be carried out comfortably.

VRV III-S heat pump

Space saving solution without compromising on efficiency



- › Automatic refrigerant charge
- › Refrigerant containment check
- › Night quiet mode
- › Low noise function
- › Full inverter compressors
- › Reluctance brushless DC compressor
- › Sine wave DC inverter
- › DC fan motor
- › E-pass heat exchanger
- › I demand function

Space saving design

The VRVIII-S is slimmer and more compact, resulting in significant savings in installation space.

Volume:

Approx. 70% reduction

Footprint:

Approx. 60% reduction

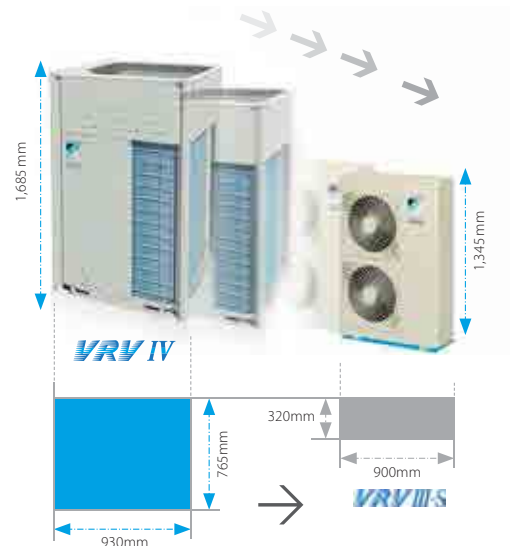

Wide range of indoor units

Connect VRV units...



... or stylish indoor units

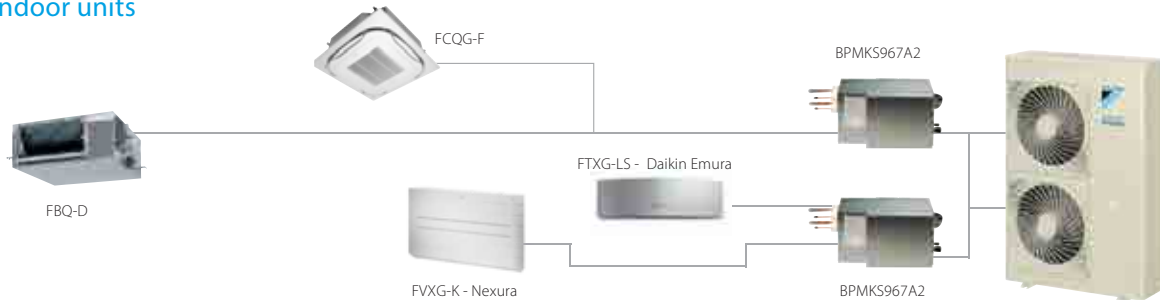

Connectable stylish indoor units

	15 CLASS	20 CLASS	25 CLASS	35 CLASS	42 CLASS	50 CLASS	60 CLASS	71 CLASS
Round flow cassette				FCQG35F		FCQG50F	FCQG60F	
Fully flat cassette			FFQ25C	FFQ35C		FFQ50C	FFQ60C	
Small concealed ceiling unit			FDBQ25B					
Slim concealed ceiling unit			FDXS25F	FDXS35F		FDXS50F9	FDXS60F	
Concealed ceiling unit with inverter driven fan				FBQ35D		FBQ50D	FBQ60D	
NEW Daikin Emura – Wall mounted unit		FTXG20LW FTXG20LS	FTXG25LW FTXG25LS	FTXG35LW FTXG35LS		FTXG50LW FTXG50LS		
Wall mounted unit	CTXS15K	FTXS20K	FTXS25K	FTXS35K CTXS35K	FTXS42K	FTXS50K	FTXS60G	FTXS71G
Ceiling suspended unit				FHQ35C		FHQ50C	FHQ60C	
Nexura – Floor standing unit			FVXG25K	FVXG35K		FVXG50K		
Floor standing unit			FVXS25F	FVXS35F		FVXS50F		
Flexi type unit			FLXS25B	FLXS35B9		FLXS50B	FLXS60B	

For more info about Daikins stylish indoor units, please check our indoor unit-portfolio

* VRV indoor units and stylish indoor units cannot be combined.

* To connect stylish indoor units a BPMKS unit is needed



High COP values

A major feature of VRVIII-S is its exceptional energy efficiency. The system achieves high COPs during both cooling and heating operation by the use of refined components and functions.

- ¹ Nominal cooling capacities are based on: indoor temperature: 27°CDB, 19°CWB, outdoor temperature: 35°C, equivalent refrigerant piping: 5m, level difference: 0m.
- ² Nominal heating capacities are based on: indoor temperature: 20°CDB, outdoor temperature: 7°CDB, 6°CWB, equivalent refrigerant piping: 5m, level difference: 0m

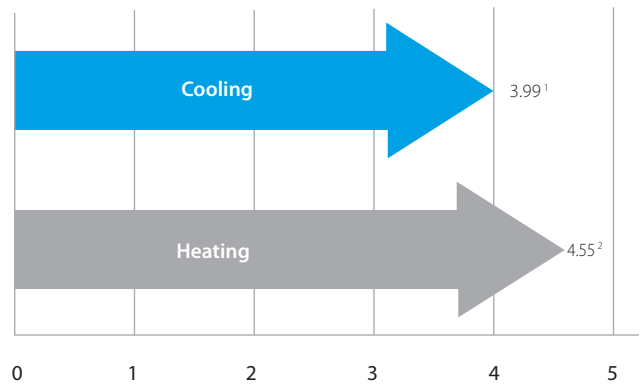

Flexible piping design

	VRV indoors connected	Stylish indoors connected
Total piping length	300m	250m
Longest length actual (Equivalent)	150m (175m)	
Minimum piping length between outdoor unit and first branch	-	5m
Minimum piping length between BP and indoor unit	-	2m
Maximum piping length between BP and indoor unit	-	15m
Longest length after first branch	40m	40m
Level difference between indoor and outdoor units	50m (40m ¹)	30m
Level difference between indoor units	15m	15m

¹ Outdoor unit in lowest position

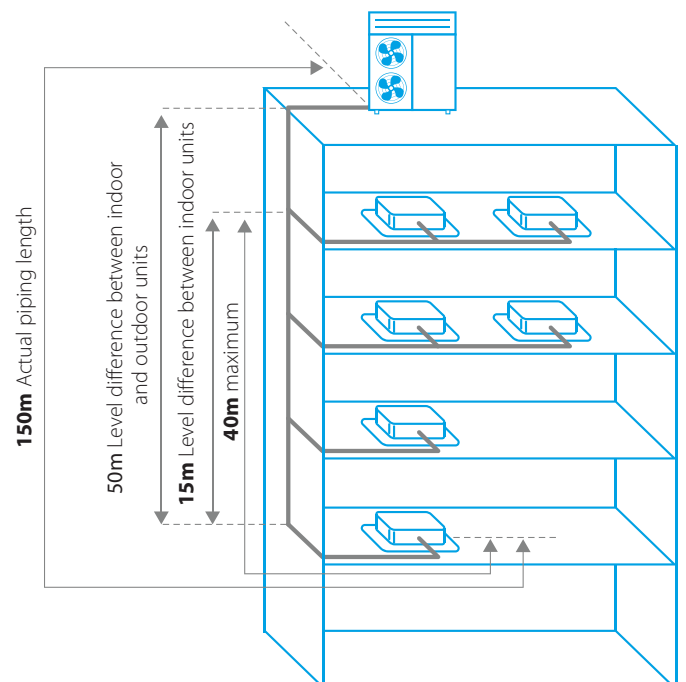

Advanced technologies

1. Super aero grille

The spiral shaped ribs are aligned with the direction of discharge flow in order to minimise turbulence and reduce noise.

2. Smooth air inlet bell mouth and aero spiral fan

These features assist in significantly reducing noise. Guides are added to the bell mouth intake to reduce turbulence in the air flow generated by fan suction. The aero spiral fan features fan blades with bent blade edges, further reducing turbulence.

Escaping edges are sucked in by the bent blade edges, reducing overall turbulence.

VRV III-S



Aero spiral fan blade tips

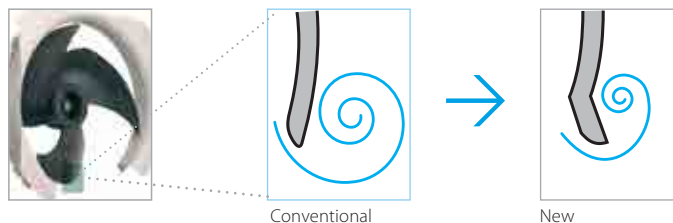

3. e-Bridge circuit

Prevents accumulation of liquid refrigerant in the condenser. This results in more efficient use of the condenser surface under all conditions and leads in turn to better energy efficiency. Increased evaporative capacity stems from the newly developed refrigeration circuit, the S_{Ce}-bridge circuit, which adds super cooling prior to the expansion cycle. By adopting this circuit, the COPs in both cooling and heating have been drastically improved.

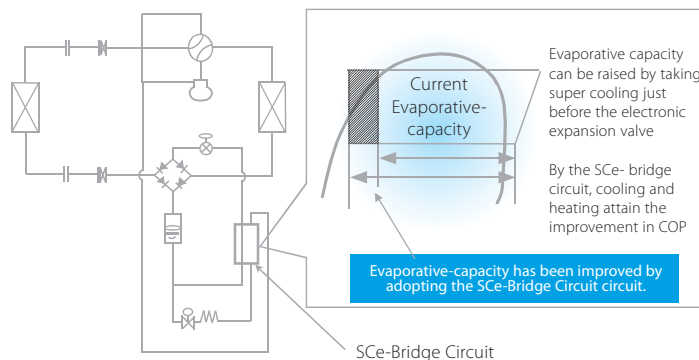



VRV IV S-series

Space saving solution without compromising on efficiency

In 2015 our successful Mini VRV range gets a thorough update to make it even better suited for light commercial applications where space is limited and performance expectations are high.

VRV IV S-series



- › Variable Refrigerant Temperature
- › Connect a wide range of up to 9 indoor units: either connect VRV or stylish indoor units (Daikin Emura, Nexura, ...)
- › All indoor units can be individually controlled
- › Connects to all VRV control, ventilation, air handling units and Biddle air curtains
- › Space saving design
- › More flexibility through extension of the range



- › The most compact VRV
- › Low height resulting in minimum visual impact
- › Lightweight reduces installation time and manpower to an absolute minimum
- › Available in single phase



- › Available in single phase and three phase
- › Extended range with 8, 10 and 12 HP unit for bigger applications with space limitations

VRV III-S heat pump

Space saving solution without compromising on efficiency

- › For residential and light commercial applications
- › Wide range of indoor units: either connect VRV or stylish indoor units such as Daikin Emura, Nexura ...
- › Energy efficient heating system based on air source heat pump technology, lowering energy bills and CO₂ emissions
- › Connect up to 9 indoor units, which can all be individually controlled
- › Possibility to combine different types of indoor units: wall mounted, floor standing, concealed ceiling, ceiling suspended, round flow or 4-way blow cassettes
- › 3 steps in night quiet mode: step 1: 47dBA, step 2: 44 dBA, step 3: 41 dBA
- › Contains all standard VRV features



Outdoor Unit Product Range

Outdoor unit				RXYSQ	4P8V1	5P8V1	6P8V1	4P8Y1	5P8Y1	6P8Y1
Capacity range				HP	4	5	6	4	5	6
Cooling capacity	Nom.			kW	12.6	14.0	15.5	12.6	14.0	15.5
Heating capacity	Nom.			kW	14.2	16.0	18.0	14.2	16.0	18.0
Power input - 50Hz	Cooling	Nom.		kW	3.24	3.51	4.53	3.33	3.61	4.66
	Heating	Nom.		kW	3.12	3.86	4.57	3.21	3.97	4.70
EER					3.89	3.99	3.42	3.78	3.88	3.33
COP					4.55	4.15	3.94	4.42	4.03	3.83
Maximum number of connectable indoor units					8 (1) / 8 (2)	10 (1) / 9 (2)	12 (1) / 9 (2)	8 (1) / 8 (2)	10 (1) / 9 (2)	12 (1) / 9 (2)
Indoor index connection	Min.				50	62.5	70	50	62.5	70
	Nom.									
	Max.				130	162.5	182	130	162.5	182
Dimensions	Unit	HeightxWidthxDepth		mm	1,345x900x320					
Weight	Unit			kg	120					
Fan	Air flow rate	Cooling	Nom.	m ³ /min	106					
Sound power level	Cooling	Nom.		dBA	66	67	69	66	67	69
	Heating	Nom.		dBA	50	51	53	50	51	53
Sound pressure level	Cooling	Nom.		dBA	52	53	55	52	53	55
	Heating	Nom.		dBA						
Operation range	Cooling	Min.~Max.		°CDB	-5~46					
	Heating	Min.~Max.		°CWB	-20~-15.5					
Refrigerant	Type / GWP				R-410A / 2,087.5					
	Charge			kg/TCO,Eq	4.0/8.4					
Piping connections	Liquid	OD		mm	9.52					
	Gas	OD		mm	15.9 / 19.1		19.1	15.9 / 19.1		19.1
	Total piping length	System	Actual	m	300 / 115	300 / 135	300 / 145	300 / 115	300 / 135	300 / 145
Power supply	Phase/Frequency/Voltage			Hz/V	1N~/50/220-240			3N~/50/380-415		
Current - 50Hz	Maximum fuse amps (MFA)			A	32.0			16.0		

(1) In case VRV indoor units are connected (2) In case RA indoors are connected

RXYSQ-P8V1

RXYSQ-P8V1

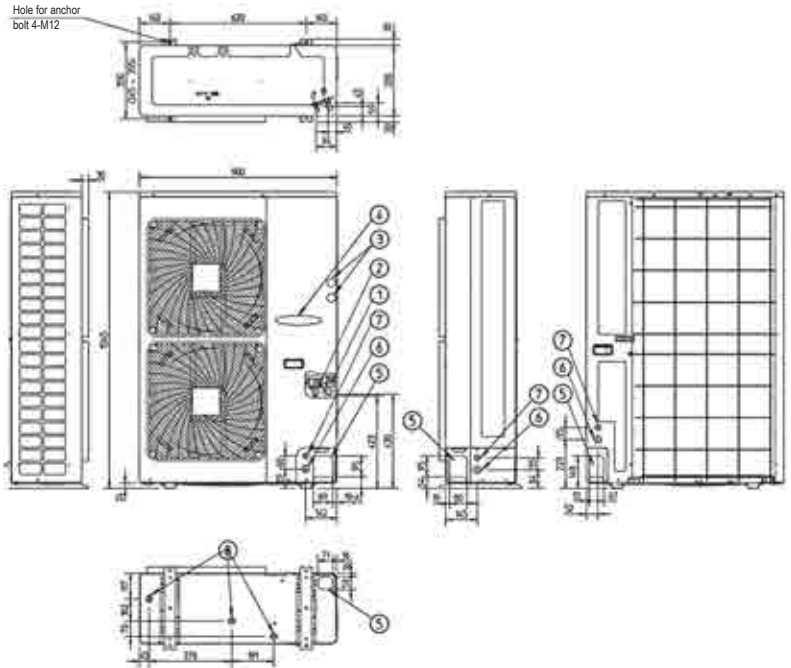

1	Gas pipe connection A
2	Liquid connection pipe Ø9.5 flare
3	Service port (in the unit) (2x)
4	Electronic connection and grounding terminal M5 (in switch box)
5	Refrigerant piping intake
6	Power supply wiring intake (knock hole Ø34)
7	Control wiring intake (knock hole Ø27)
8	Drain outlet

MODEL	A	
	With RA connection	With VRV correction
RXYSQ4P8V1	Ø19.1 Brazing	Ø15.9 Flare
RXYSQ5P8V1	Ø19.1 Brazing	Ø15.9 Flare
RXYSQ6P8V1	Ø19.1 Brazing	Ø19.1 Brazing

3TW30374-1B

RXYSQ-P8Y1

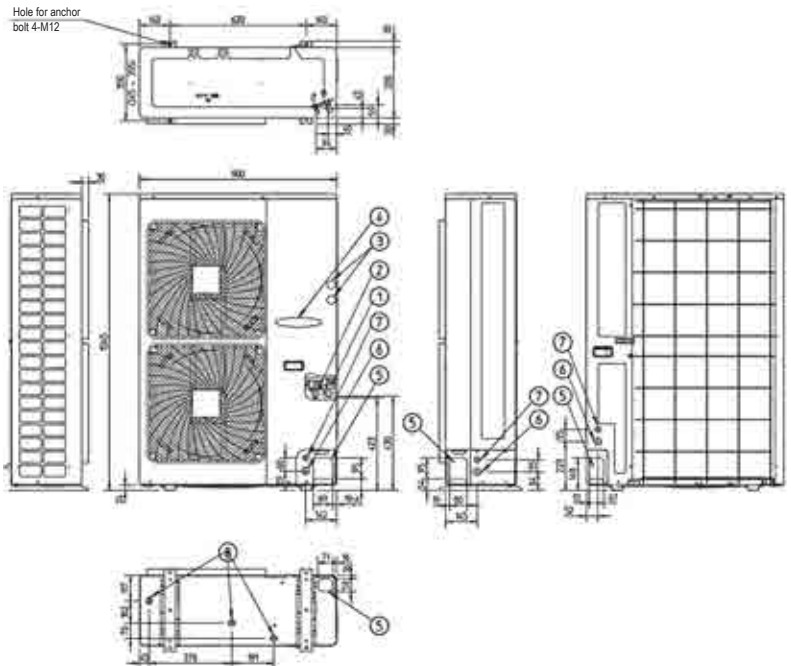

1	Gas pipe connection A
2	Liquid connection pipe Ø9.5 flare
3	Service port (in the unit) (2x)
4	Electronic connection and grounding terminal M5 (in switch box)
5	Refrigerant piping intake
6	Power supply wiring intake (knock hole Ø34)
7	Control wiring intake (knock hole Ø27)
8	Drain outlet

MODEL	A	
	With RA connection	With VRV correction
RXYSQ4P8Y1	Ø19.1 Brazing	Ø15.9 Flare
RXYSQ5P8Y1	Ø19.1 Brazing	Ø15.9 Flare
RXYSQ6P8Y1	Ø19.1 Brazing	Ø19.1 Brazing

3TW30374-1B

Required installation space
(The unit of these values is 'mm')

1. Where there is an obstacle on the suction side:

(a) No obstacle above

- (1) Stand-alone installation
 - Obstacle on the suction side only

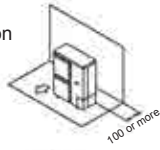

- Obstacle on both sides

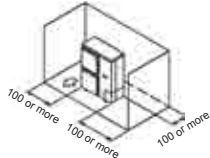

(2) Series installation (2 or more)

- Obstacle on both sides

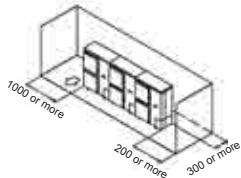

(b) Obstacle above, too

- (1) Stand-alone installation
 - Obstacle on the suction side, too

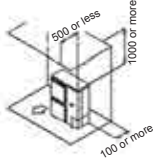

- Obstacle on the suction side and both sides

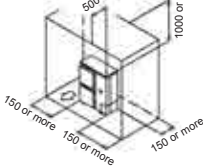

(2) Series installation (2 or more)

- Obstacle on the suction side and both sides

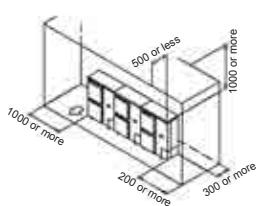

2. Where there is an obstacle on the discharge side:

(a) No obstacle above

- (1) Stand-alone installation

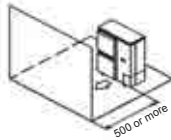

(2) Series installation (2 or more)

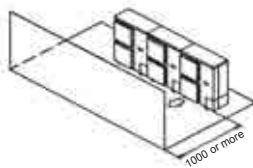

(a) Obstacle above, too

- (1) Stand-alone installation

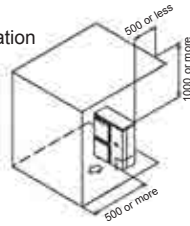

(2) Series installation (2 or more)

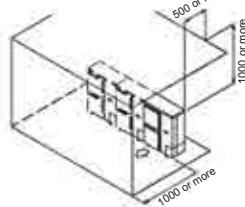

3. Where there are obstacles on both suction and discharge sides:

Pattern 1

Where the obstacle on the discharge side is higher than the unit:

(There is no height limit for obstructions on the intake side)

(a) No obstacle above

- (1) Stand-alone installation

$L > H$

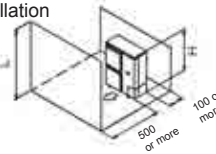

(2) Series installation (2 or more)

$L > H$

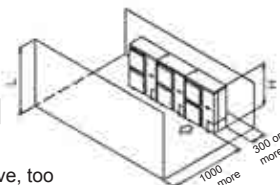

(b) Obstacle above, too

- (1) Stand-alone installation

The relations between H, A and L are as follows

	L	A
$L \leq H$	$0 < L \leq 1/2 H$	750
	$1/2 H < L \leq H$	1000
$H < L$	Set the stand as: $L \leq H$	

Close the bottom of the installation frame to prevent the discharged air from being bypassed.

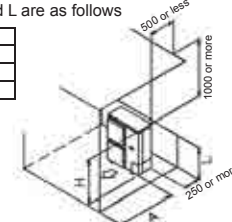

(2) Series installation (2 or more)

The relations between H, A and L are as follows:

	L	A
$L \leq H$	$0 < L \leq 1/2 H$	1000
	$1/2 H < L \leq H$	1250
$H < L$	Set the stand as: $L \leq H$	

Close the bottom of the installation frame to prevent the discharged air from being bypassed.

Only two units can be installed for this series

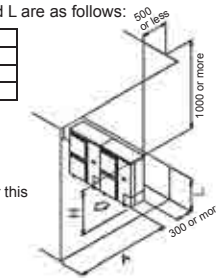

Pattern 2

Where the obstacle on the discharge side is lower than the unit:

(There is no height limit for obstructions on the intake side)

(a) No obstacle above

- (1) Stand-alone installation

$L \leq H$

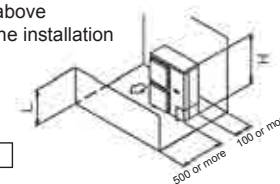

(2) Series installation (2 or more)

The relations between H, A and L are as follows

	L	A
$L \leq H$	$0 < L \leq 1/2 H$	250
	$1/2 H < L \leq H$	300

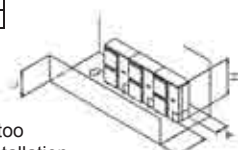

(b) Obstacle above, too

- (1) Stand-alone installation

The relations between H, A and L are as follows:

	L	A
$L \leq H$	$0 < L \leq 1/2 H$	100
	$1/2 H < L \leq H$	200
$H > L$	Set the stand as: $L \leq H$	

Close the bottom of the installation frame to prevent the discharged air from being bypassed.

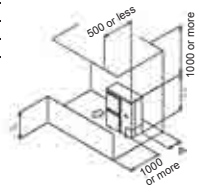

(2) Series installation

The relations between H, A and L are as follows

	L	A
$L \leq H$	$0 < L \leq 1/2 H$	250
	$1/2 H < L \leq H$	300
$H < L$	Set the stand as: $L \leq H$	
	Refer to the column of $L \leq H$ for A	

Close the bottom of the installation frame to prevent the discharged air from being bypassed.

Only two units can be installed for this series.

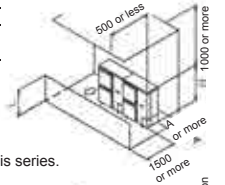

4. Double-decker installation

- (a) Obstacle on the discharge side close the gap A (the gap between the upper and lower outdoor units) to prevent the discharged air from being bypassed.

Do not stack more than two units.

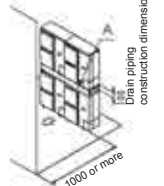

- (b) Obstacle on the suction side close the gap A (the gap between the upper and lower outdoor units) to prevent the discharged air from being bypassed.

Do not stack more than two units.

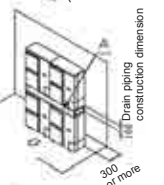

5. Multiple rows of series installation (on the rooftop, etc.)

- (a) One row of stand-alone installation

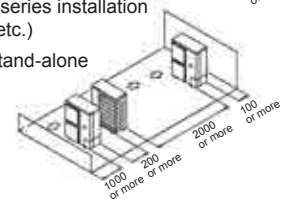

- (b) Rows of series installation (2 or more)

The relations between H, A and L are as follows

	L	A
$L \leq H$	$0 < L \leq 1/2 H$	250
	$1/2 H < L \leq H$	300
$H < L$	Can not be installed	

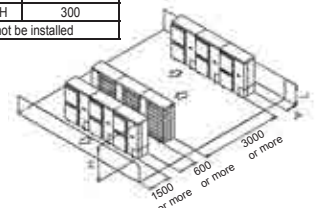

VRV8-C

VRV heat pump

where heating is priority

without compromising on efficiency



- › Automatic refrigerant charge
- › Refrigerant containment check
- › Night quiet mode
- › Low noise function
- › Reluctance brushless DC compressor
- › Sine wave DC inverter
- › DC fan motor
- › E-pass heat exchanger
- › I demand function



High COP at low ambients

The use of two stage compression technology results in improved energy saving performance at low ambients, with a COP of more than 3.0 at -10°C outdoor ambient for the entire range.

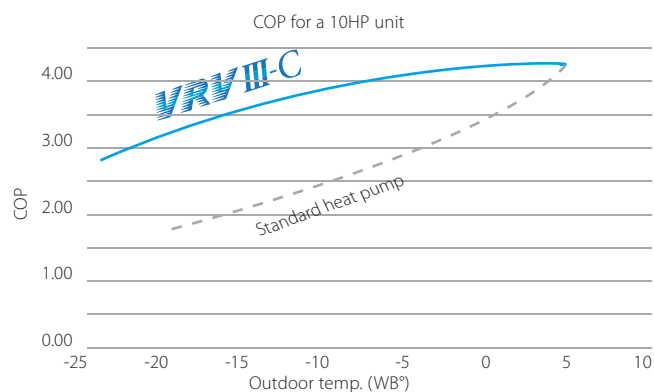

Wide heating operation range

VRV III-C has a standard operation range down to -25°CWB outdoor ambient in heating and can also provide cooling down to -5°CDB outdoor ambient.

Heating mode

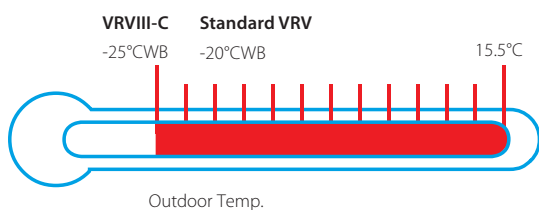

Cooling mode

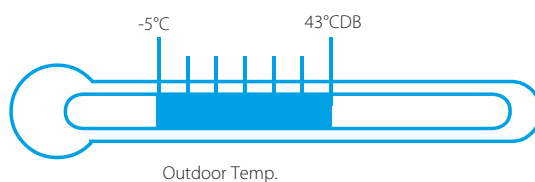

Stable heating capacity

VRV III-C has a stable heating capacity, even in low ambients, making it suitable for single source heating. The heating capacity is 130% in comparison with the standard VRV heating capacity under similar conditions.

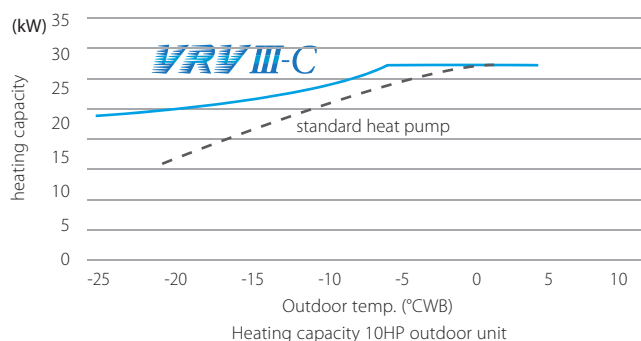

High heat up speed

Heat up time is dramatically reduced, particularly under low ambient conditions. The required time for the indoor unit heat exchanger discharge temperature to reach 40°C has been reduced by 50%.

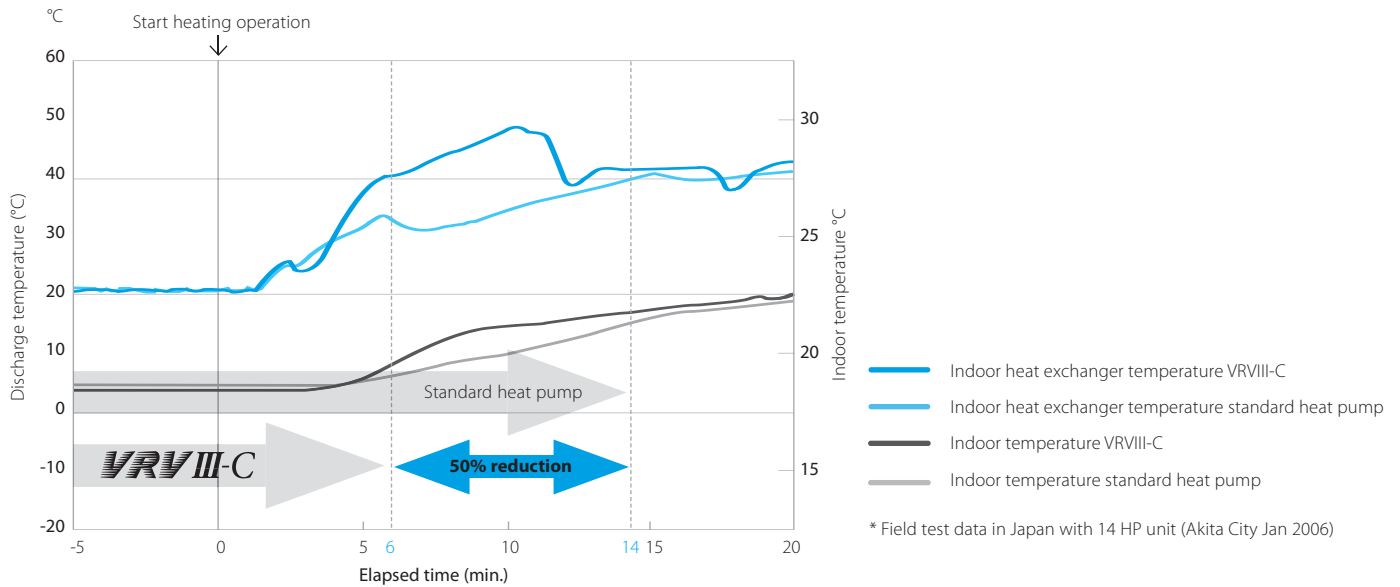

Short defrost time

The time required for defrost is reduced to 4 minutes – less than half that of the standard VRV system (10 minutes), leading to a more stable interior indoor temperature and considerably improved comfort levels.

* Field test data in Japan with 10 HP unit (Akita City Jan 2006)

Flexible piping design

Total piping length	500m
Longest length actual (Equivalent)	165m (190m)
Longest length between outdoor unit and function unit	10m
Longest length after first branch	40m (90m ¹)
Level difference between indoor and outdoor units	50m (40m ²)
Level difference between indoor units	30m

1 Contact your local dealer for more information and restrictions
2 In case outdoor unit is located below indoor units

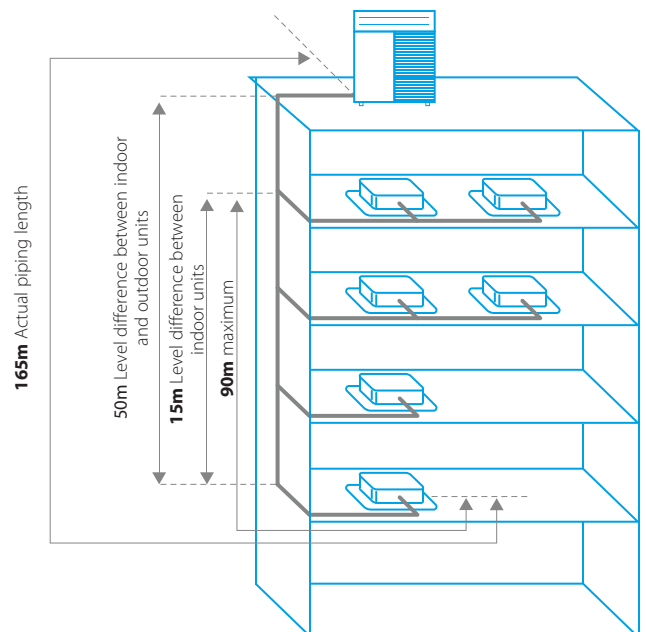

VRV III heat pump, optimised for heating

Where heating is priority without compromising on efficiency

- › First system in the industry developed for heating operation in low ambient conditions, making it suitable for single source heating
- › Extended operation range down to -25°C in heating
- › Stable heating capacity and high COP values at low ambients thanks to the two stage compression technology (COP values of 3.0 and more at -10°C)
- › Improved comfort thanks to shorter defrost time
- › Shorter heat up time compared to standard VRV III heat pump
- › Contains all standard VRV features



Two stage compression

Two stage compression technology enables the system to create higher pressures resulting in a higher heating capacity under low ambient conditions. The second inverter compressor (located in the function unit) is specially designed to provide higher pressures. After heat is exchanged in the indoor unit, gas and liquid are separated at the gas-liquid separator. This enables the refrigerant in gas condition to be recovered and transmitted direct to the high pressure compressor.

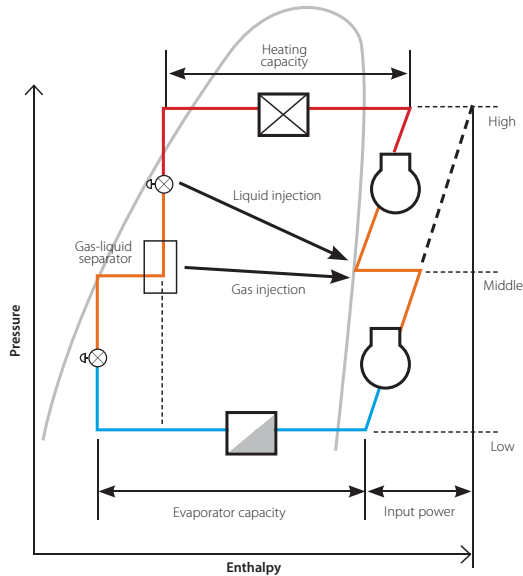

Outdoor system				RTSYQ	10PA	14PA	16PA	20PA
System	Outdoor unit module 1				RTSQ10PAY1	RTSQ14PAY1	RTSQ16PAY1	RTSQ8PAY1
	Outdoor unit module 2							RTSQ12PAY1
	Function unit				BTSQ20PY1			
Capacity range			HP	10	14	16	20	
Cooling capacity	Nom.		kW	28.0	40.0	45.0	56.0	
Heating capacity	Nom.		kW	31.5 / 28.0	45.0 / 40.0	50.0 / 45.0	63.0 / 55.9	
Power input - 50Hz	Cooling	Nom.	kW	7.90	12.6	14.9	15.4	
	Heating	Nom.	kW	7.78 / 8.18	11.4 / 12.8	13.0 / 15.0	15.4 / 18.7	
EER				3.54	3.17	3.02	3.64	
COP				4.05 / 3.42	3.95 / 3.13	3.85 / 3.00	4.09 / 2.99	
Maximum number of connectable indoor units					21	30	34	43
Indoor index connection	Min.			125	175	200	250	
	Nom.			250	350	400	500	
	Max.			325	455	520	650	
Sound pressure level	Cooling	Max./Nom.	dB(A)	62/60	63/61		65/63	
Piping connections	Liquid	OD	mm	9.52		12.7		15.9
	Gas	OD	mm	22.2			28.6	
	Oil equalizing	OD	mm					19.1
	Total piping length	System	Actual	m			500	
Current - 50Hz	Maximum fuse amps (MFA)			A	25	35	40	50

Outdoor unit module				BTSQ20P	RTSQ8PA	RTSQ10PA	RTSQ12PA	RTSQ14PA	RTSQ16PA
Dimensions	Unit	HeightxWidthxDepth		mm	1,570x460x765	1,680x930x765		1,680x1,240x765	
Weight	Unit			kg	110	205	257	338	344
Fan	Air flow rate	Cooling	Nom.	m ³ /min	-	185	200	233	239
Sound power level	Cooling	Nom.		dB(A)					
Operation range	Cooling	Min.~Max.		°CDB		-5~43			
	Heating	Min.~Max.		°CWB		-25~15.5			
Refrigerant	Type / GWP				R-410A / 2,087.5				
	Charge			kg/TCO,Eq	-	9.4/19.6	10.5/21.9	10.9/22.8	11.7/24.4
Power supply	Phase/Frequency/Voltage			Hz/V	3~/50/380-415				
Current - 50Hz	Maximum fuse amps (MFA)			A	20	25		35	40

RTSYQ10PA

RTSYQ10PA

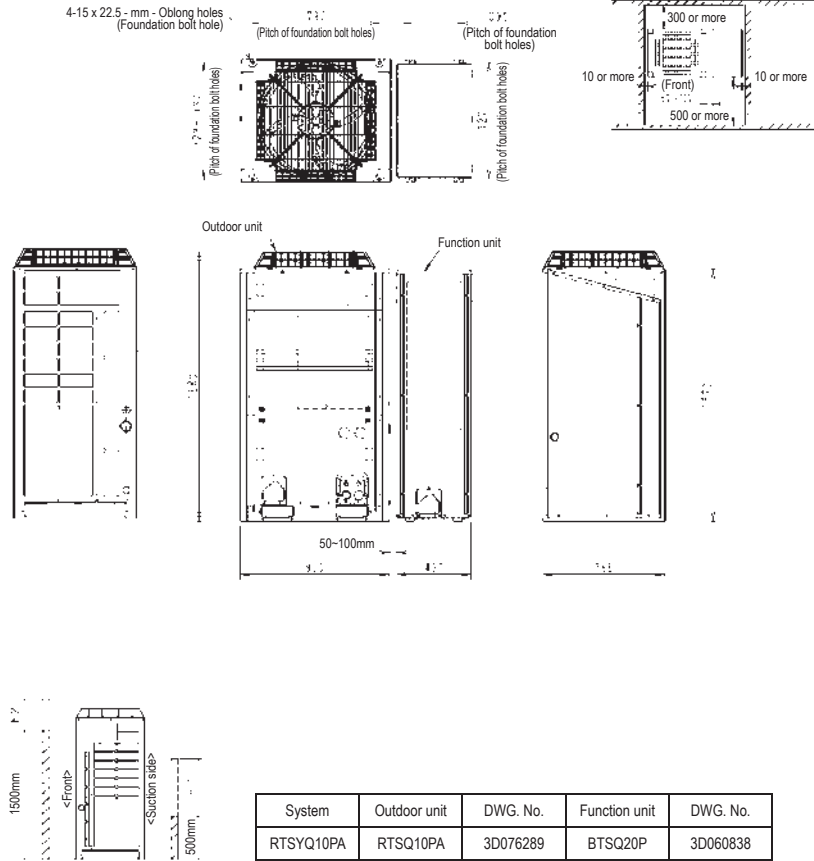

NOTES

- Heights of walls in case of Patterns 1 and 2:
Front: 1500mm
Suction side: 500mm
Side: Height unrestricted
Installation space to be shown in this drawing is based on the cooling operation at 35 degrees outdoor air temperature. When the design outdoor air temperature exceeds 35 degrees or the load exceeds maximum ability because of much generation load of heat in all outdoor unit, take the suction side space more broadly than the space to be shown in this drawing.
- If the above wall heights are exceeded then h/2 and h1/2 should be added to the front and suction side service spaces respectively as shown in the figure on the right.
- When installing the units most appropriate pattern should be selected from those shown above in order to obtain the best fit in the space available always bearing in mind the need to leave enough space for a person to pass between units and wall and for the air to circulate freely. (If more units are to be installed than are catered for in the above patterns your layout should take account of the possibility of short circuits.)
- The units should be installed to leave sufficient space at the front for the on site refrigerant piping work to be carried out comfortably.
- In case there expected heavy snow, prepare some countermeasures recommended as follows:
1) Outdoor and Function unit must be installed on a foundation (field supply) in order to secure a distance of 200-300mm or more between the bottom frame and the snow-laid ground surface.
2) Install a snowbreak hood (option) and remove its back side air inlet grill.
- Air outlet of snowbreak hood must face at right angle or lower level than the winter wind, in case a snowbreak hood is installed at the air outlet of the unit.
- In case there expected to freeze of exhausted water from de-frost operation due to the cold outdoor temperature in winter time, secure a sufficient space between the bottom frame and the foundation. (500-1000mm is suggested as an appropriate distance.)

3D076286

RTSYQ14,16PA

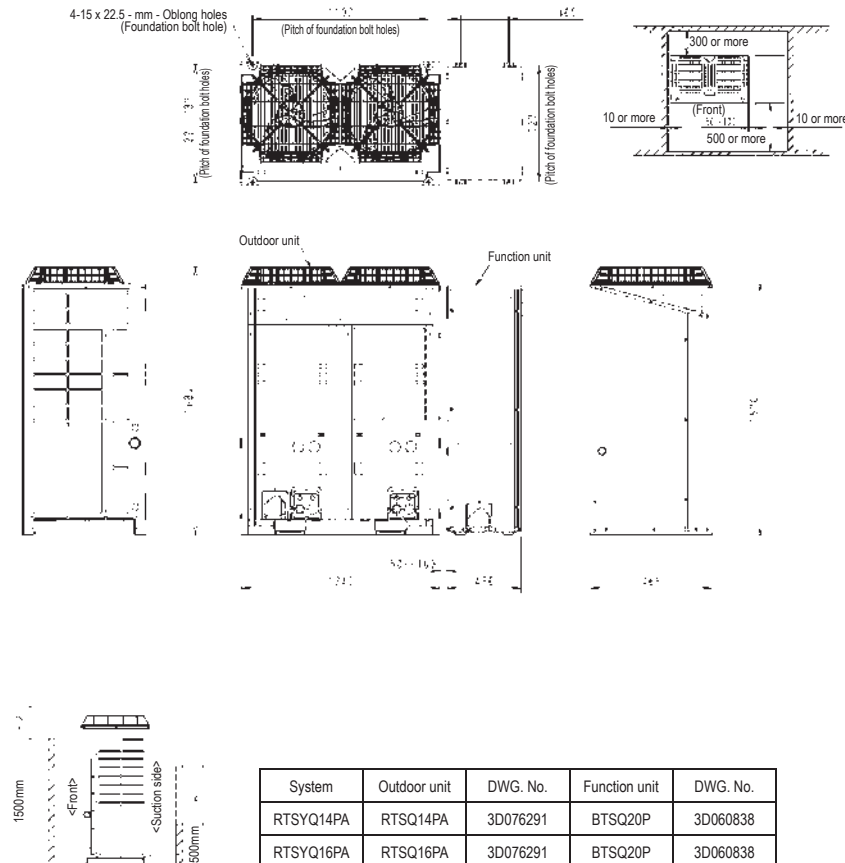

NOTES

- Heights of walls in case of Patterns 1 and 2:
Front: 1500mm
Suction side: 500mm
Side: Height unrestricted
Installation space to be shown in this drawing is based on the cooling operation at 35 degrees outdoor air temperature. When the design outdoor air temperature exceeds 35 degrees or the load exceeds maximum ability because of much generation load of heat in all outdoor unit, take the suction side space more broadly than the space to be shown in this drawing.
- If the above wall heights are exceeded then h/2 and h1/2 should be added to the front and suction side service spaces respectively as shown in the figure on the right.
- When installing the units most appropriate pattern should be selected from those shown above in order to obtain the best fit in the space available always bearing in mind the need to leave enough space for a person to pass between units and wall and for the air to circulate freely. (If more units are to be installed than are catered for in the above patterns your layout should take account of the possibility of short circuits.)
- The units should be installed to leave sufficient space at the front for the on site refrigerant piping work to be carried out comfortably.
- In case there expected heavy snow, prepare some countermeasures recommended as follows:
1) Outdoor and Function unit must be installed on a foundation (field supply) in order to secure a distance of 200-300mm or more between the bottom frame and the snow-laid ground surface.
2) Install a snowbreak hood (option) and remove its back side air inlet grill.
- Air outlet of snowbreak hood must face at right angle or lower level than the winter wind, in case a snowbreak hood is installed at the air outlet of the unit.
- In case there expected to freeze of exhausted water from de-frost operation due to the cold outdoor temperature in winter time, secure a sufficient space between the bottom frame and the foundation. (500-1000mm is suggested as an appropriate distance.)

3D076287

VRV Classic heat pump RXYCQ-A

For standard cooling & heating requirements

Indoor units
VRV type indoor units

Ventilation
Heat Reclaim ventilation (VAM/VKM)

Control systems



- › Low noise function
- › Reluctance brushless DC compressor
- › Sine wave DC inverter
- › DC fan motor
- › E-pass heat exchanger
- › Manual demand function



Benefits

- › For projects with standard cooling & heating requirements
- › Fits any building as also indoor installation is possible as a result of high external static pressure of up to 78.4 Pa. Indoor installation leads to less piping length, lower installation costs, increased efficiency and better visual aesthetics
- › The ability to control each conditioned zone individually keeps VRV system running costs to an absolute minimum
- › Spread your installation cost by phased installation
- › Connectable to all standard VRV indoor units, controls and ventilation

Flexible piping design

Total piping length	300m
Longest length actual (Equivalent)	135m (155m)
Longest length after first branch	40m (90m ¹)
Level difference between indoor and outdoor units	30m
Level difference between indoor units	15m

¹ Contact your local dealer for more information and restrictions

VRV Classic

Classic VRV configuration

- › For standard cooling & heating requirements
- › Connectable to all standard VRV indoor units, controls and ventilation
- › Contains all standard VRV features



Outdoor unit				RXYCQ	8A	10A	12A	14A	16A	18A	20A
Capacity range				HP	8	10	12	14	16	18	20
Cooling capacity	Nom.			kW	20.0	25.0	30.0	35.0	40.0	45.0	50.4
Heating capacity	Nom.			kW	22.4	28.0	33.6	31.5	44.8	50.4	56.5
Power input - 50Hz	Cooling	Nom.		kW	6.60	6.74	8.77	11.4	12.9	15.0	17.9
	Heating	Nom.		kW	5.80	7.00	8.62	8.18	11.8	13.8	16.1
EER					3.03	3.71	3.42	3.07	3.10	3.00	2.81
COP					3.86	4.00	3.90	3.85	3.80	3.65	3.50
Maximum number of connectable indoor units					64						
Indoor index connection	Min.				100	125	150	175	200	225	250
	Nom.				200	250	300	350	400	450	500
	Max.				200	250	360	420	480	540	600
Dimensions	Unit	Height	Width	Depth	mm	1,680x930x765			1,680x1,240x765		
Weight	Unit			kg	159	187	240		316		324
Fan	Air flow rate	Cooling	Nom.	m ³ /min	95	171	185	196	233		239
Sound power level	Cooling	Nom.			dB(A)	78	81		86		88
Sound pressure level	Cooling	Nom.			dB(A)	58	59	61	64	65	66
Operation range	Cooling	Min.~Max.			°CDB	-5~43					
	Heating	Min.~Max.			°CWB	-20~15.5					
Refrigerant	Type / GWP				R-410A / 2,087.5						
	Charge			kg	6.2	7.7	8.4	8.6	11.3	11.5	17.7
	Charge			TCO,Eq	12.9	16.1	17.5	18	23.6	24	24.4
Piping connections	Liquid	OD			mm	9.52		12.7		15.9	
	Gas	OD			mm	15.9	19.1	22.2	28.6		
	Total piping length	System	Actual	m	300						
Power supply	Phase/Frequency/Voltage			Hz/V	3N~/50/380-415						
Current - 50Hz	Maximum fuse amps (MFA)			A	16	25			40		

RXYCQ8A

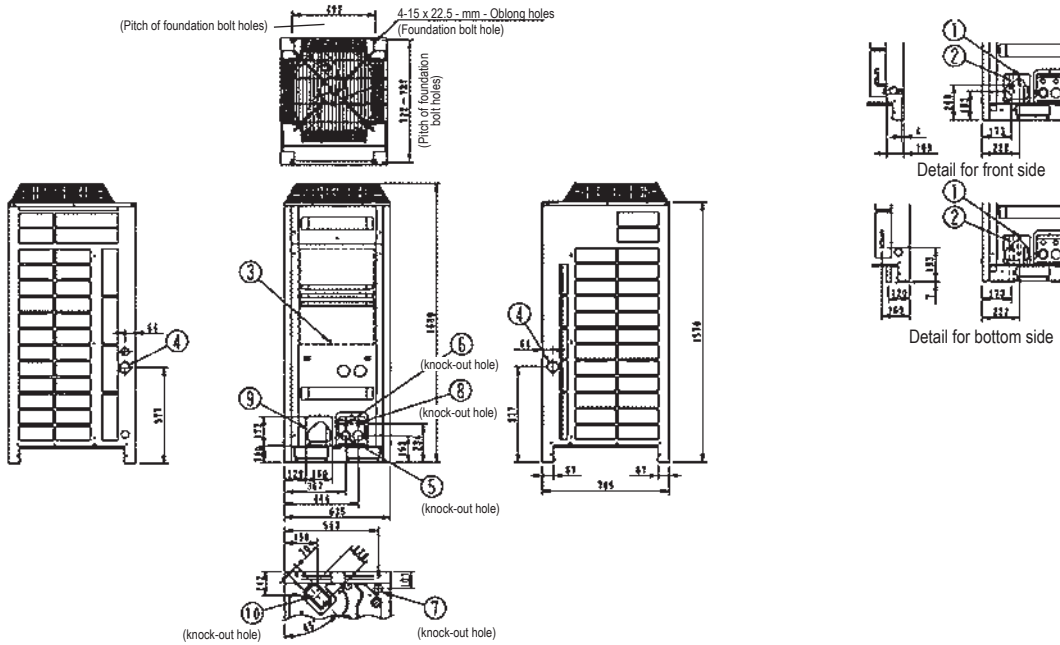

No.	Parts name	Remarks
1	Liquid pipe connection port	ø 9.5 Brazing connection
2	Gas pipe connection port	ø 15.9 Brazing connection
3	Grounding terminal	Inside of switch box (M8)
4	Power cord routing hole (side)	ø 62
5	Power cord routing hole (front)	ø 45
6	Power cord routing hole (front)	ø 27
7	Power cord routing hole (bottom)	ø 50
8	Wire routing hole (front)	ø 27
9	Pipe routing hole (front)	
10	Pipe routing hole (bottom)	

NOTES

- Detail for front side and detail for bottom side indicate the dimensions after fixing the attached piping.

3D080764

RXYCQ10-14A

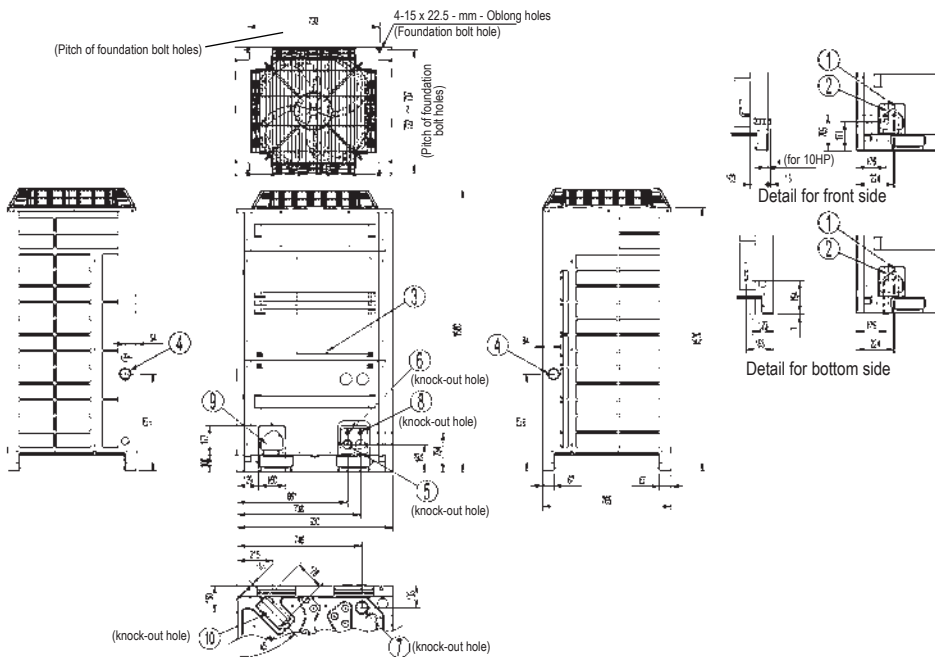

No.	Parts name	Remarks
1	Liquid pipe connection port	See note 2
2	Gas pipe connection port	See note 2
3	Grounding terminal	Inside of switch box (M8)
4	Power cord routing hole (side)	ø 62
5	Power cord routing hole (front)	ø 45
6	Power cord routing hole (front)	ø 27
7	Power cord routing hole (bottom)	ø 65.5
8	Wire routing hole (front)	ø 27
9	Pipe routing hole (front)	
10	Pipe routing hole (bottom)	

NOTES

- Detail for front side and detail for bottom side indicate the dimensions after fixing the attached piping.
- Gas pipe:
 ø 19.1 Brazing connection: RXYCQ10
 ø 22.2 Brazing connection: RXYCQ12
 ø 28.6 Brazing connection: RXYCQ14
 Liquid pipe:
 ø 9.5 Brazing connection: RXYCQ10, RXYCQ12
 ø 28.6 Brazing connection: RXYCQ14

3D080763

RXYCQ16-20A

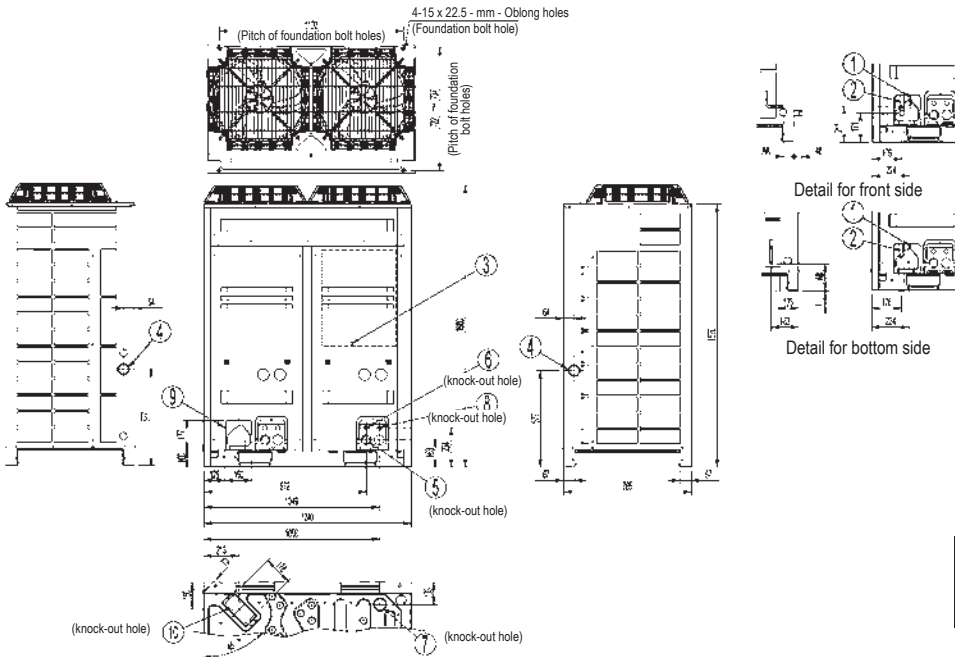

Model	AA	AB
RXYCQ16	83	179
RXYCQ18	83	179
RXYCQ20	63	160

No.	Parts name	Remarks
1	Liquid pipe connection port	See note 2
2	Gas pipe connection port	See note 2
3	Grounding terminal	Inside of switch box (M8)
4	Power cord routing hole (side)	ø 62
5	Power cord routing hole (front)	ø 45
6	Power cord routing hole (front)	ø 27
7	Power cord routing hole (bottom)	ø 65.5
8	Wire routing hole (front)	ø 27
9	Pipe routing hole (front)	
10	Pipe routing hole (bottom)	

NOTES

- Detail for front side and detail for bottom side indicate the dimensions after fixing the attached piping.
- Gas pipe:
ø 28.6 Brazing connection: RXYCQ16,18,20
Liquid pipe:
ø 12.7 Brazing connection: RXYCQ20
ø 9.5 Brazing connection: RXYCQ16,18

3D080767

RXYCQ-A

RXYCQ-A

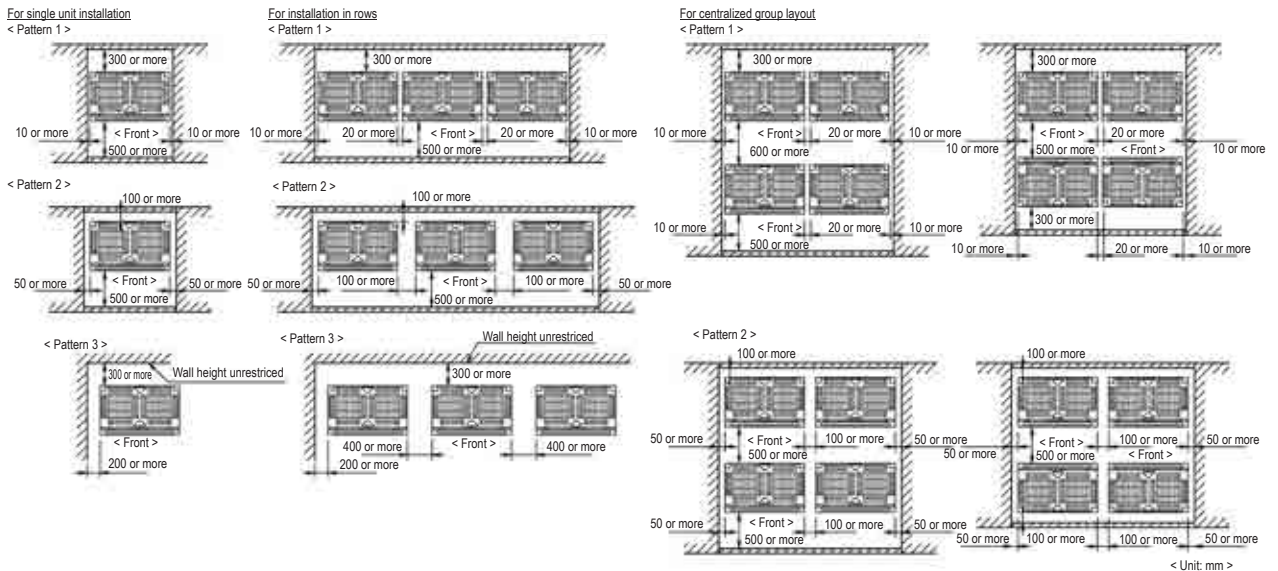

NOTES

- Heights of walls in case of Patterns 1 and 2:
Front: 1500mm
Suction side: 500mm
Side: height unrestricted.
Installation space to be shown in this drawing is based on the cooling operation at 35 degrees outdoor air temperature. When the design outdoor air temperature exceeds 35 degrees or the load exceeds maximum ability because of much generation load of heat in all outdoor unit, take the suction side space more broadly than the space to be shown in this drawing.
- If the above wall heights are exceeded then h2/2 and h1/2 should be added to the front and suction side service spaces respectively as shown in the figure on the right.
- When installing the units most appropriate pattern should be selected from those shown above in order to obtain the best fit in the space available always bearing in mind the need to leave enough space for a person to pass between units and wall and for the air to circulate freely. (If more units are to be installed than are catered for in the above patterns your layout should take account of the possibility of short circuits.)
- The units should be installed to leave sufficient space at the front for the on site refrigerant piping work to be carried out comfortably.

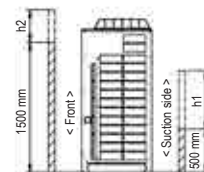

3D051451U

Replacement VRV



Quick & quality replacement for R-22 and R-407C systems

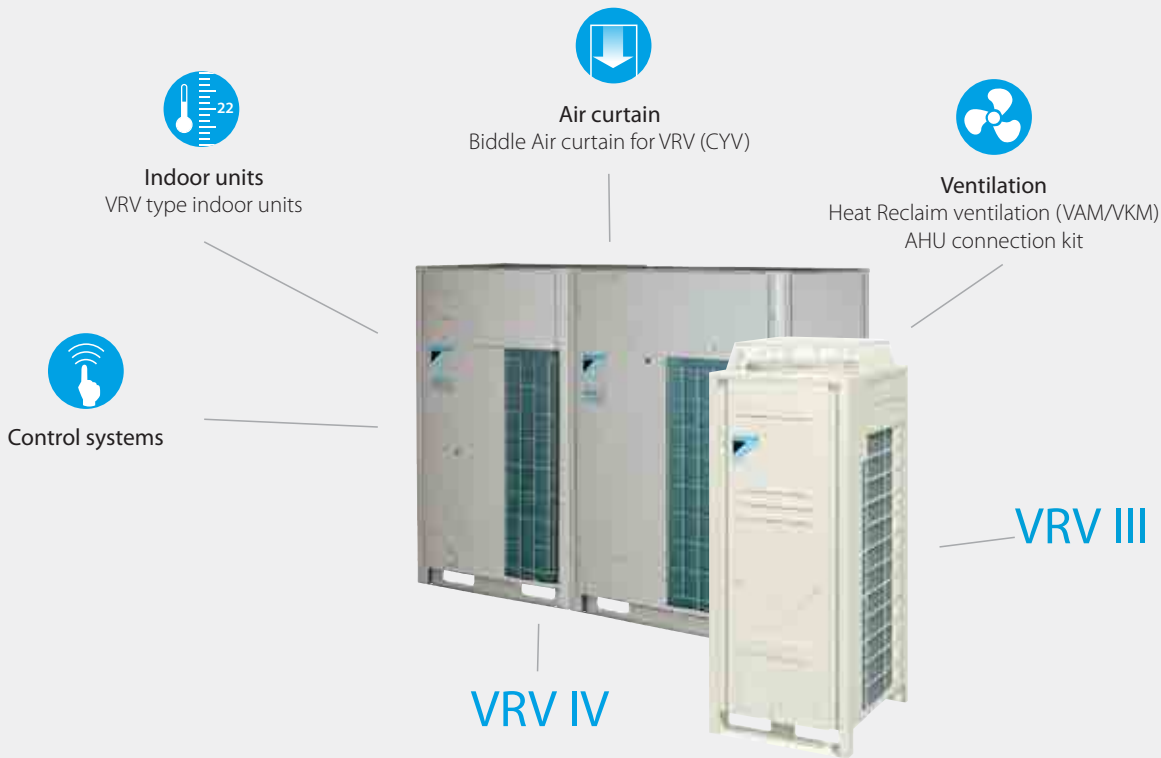

Outdoor Unit Product Range

VRV IV Q-series

Heat pump

Variable refrigerant temperature

Customize your VRV for best seasonal efficiency & comfort

VRV configurator

Software for simplified commissioning, configuration and customisation

- › 7 segment indicator
- › Automatic refrigerant charge
- › Night quiet mode
- › Low noise function
- › Full inverter compressors
- › Gas cooled PCB
- › 4 side heat exchanger
- › Reluctance brushless DC compressor
- › Sine wave DC inverter
- › DC fan motor
- › E-pass heat exchanger
- › I demand function

VRV III-Q

Heat pump & Heat recovery

- › Automatic refrigerant charge
- › Night quiet mode
- › Low noise function
- › Full inverter compressors
- › Reluctance brushless DC compressor
- › Sine wave DC inverter
- › DC fan motor
- › E-pass heat exchanger
- › I demand function

Replacement technology

The quick and quality way of upgrading R-22 and R-407C systems



The phase-out period for R-22 is over. Act now!

R-22 ban in Europe

Service and maintenance with R-22 will be prohibited after January 1st, 2015, meaning repairs will be impossible to R-22 systems. Avoid unexpected downtime for your customers and replace these systems now!

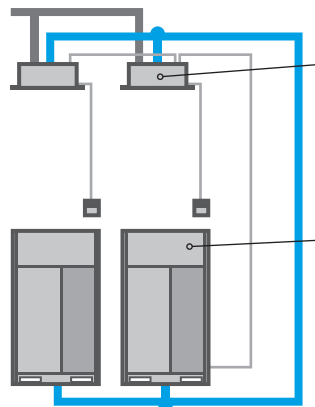

The Daikin low-cost upgrade solution

- ! **Replace indoor units and BS boxes**
Contact your local dealer to check compatibility in case you need to keep the indoor units.
- ! **Replace outdoor units**

These benefits will convince your customer

Always operational

Avoid loss of business

Replacing now prevents unplanned, lengthy downtime of air conditioning systems. It also avoids loss of business for shops, complaints from guests in hotels, lower working efficiency and loss of tenants in offices.

Quick and easy installation

No interruption of daily business while replacing the system thanks to phased-in, fast installation.

Smaller footprint, more performance

Thanks to a smaller footprint, Daikin outdoor units save space. Also, more indoor units can be connected to the new outdoor unit compared to the old system, allowing to increase capacity.

Lower long-term costs

EU Directives prohibit system repairs with R-22 after January 1st, 2015. Delaying the required R-22 replacement until an unplanned system breakdown is a losing game. Replacement day will come. Installing a technically advanced system lowers energy consumption and maintenance costs from day one.

Up to 48% less consumption

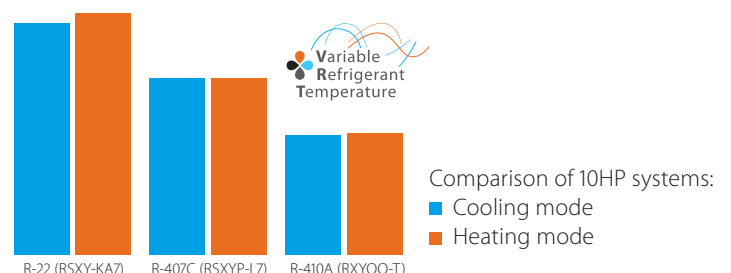



VRV-Q benefits to increase your profit

Optimise your business

Less installation time

Tackle more projects in less time thanks to faster installation. It is more profitable than replacing the full system with new piping.

Lower installation costs

Reducing installation costs enables you to offer customers the most cost-effective solution and improve your competitive edge.

Replace non-Daikin systems

It is a trouble-free replacement solution for Daikin systems and for systems made by other manufacturers.

Easy as one-two-three

A simple solution for replacement technology enables you to handle more projects for more customers in less time and offer them the best price! Everybody gains.

Automatic refrigerant charge

The unique automatic refrigerant charge eliminates the need to calculate refrigerant volume and ensures that the system will operate perfectly. Not knowing the exact piping lengths because of changes or mistakes in case you didn't do the original installation or replacing a competitor installation no longer poses a problem.

Automatic pipe cleaning

There is no need to clean inside piping as this is handled automatically by the VRV-Q unit. Finally the test operation is performed automatically to save time.

Compare installation steps

Conventional solution

- 1 Recover refrigerant
- 2 Remove units
- 3 Remove refrigerant pipes
- 4 Install new piping and wiring
- 5 Install new units
- 6 Leak test
- 7 Vacuum drying
- 8 Refrigerant charging
- 9 Collect contamination
- 10 Test operation

VRV-Q

- 1 Recover refrigerant
 - 2 Remove units
- Re-use existing piping and wiring
- 3 Install new units
 - 4 Leak test
 - 5 Vacuum drying
 - 6 Automatic refrigerant charging, cleaning and testing



Up to 45% shorter installation time



One touch convenience:

- > Measure and charge refrigerant
- > Automatic pipe cleaning
- > Test operation





Replacement VRV

Quick & quality replacement for R-22 and R-407C systems

- › Cost-effective and fast replacement through re-use of existing piping
- › Up to 80% more efficient than R-22 systems
- › No interruption of daily business while replacing your system
- › Replace Daikin and other manufacturers systems safely
- › Automatic cleaning of refrigerant pipe work ensures a quality replacement
- › Possibility to increase capacity
- › Limited and phased investment cost
- › Incorporates VRV IV standards & technologies: Variable Refrigerant Temperature, VRV configurator, 7 segment display and full inverter compressors, 4-side heat exchanger, refrigerant cooled PCB, new DC fan motor (for RXYQQ-T only)
- › Contains all standard VRV features



RQCEQ712-848P

Outdoor system		RQCEQ	280P	360P	460P	500P	540P	636P	712P	744P	816P	848P	
System	Outdoor unit module 1		RQEQ140P	RQEQ180P	RQEQ140P		RQEQ180P	RQEQ212P	RQEQ140P		RQEQ180P	RQEQ212P	
	Outdoor unit module 2		RQEQ140P	RQEQ180P	RQEQ140P	RQEQ180P		RQEQ212P	RQEQ180P		RQEQ212P		
	Outdoor unit module 3		-		RQEQ180P			RQEQ212P	RQEQ180P	RQEQ212P			
	Outdoor unit module 4		-						RQEQ212P		RQEQ212P		
Capacity range		HP	10	13	16	18	20	22	24	26	28	30	
Cooling capacity	Nom.	kW	28.0	36.0	45.0	50.0	54.0	63.6	71.2	74.4	81.6	84.8	
Heating capacity	Nom.	kW	32.0	40.0	52.0	56.0	60.0	67.2	78.4	80.8	87.2	89.6	
Power input - 50Hz	Cooling	Nom.	kW	7.04	10.3	12.2	13.9	15.5	21.9	21.2	23.3	27.1	29.2
	Heating	Nom.	kW	8.00	10.7	13.4	14.7	16.1	17.7	20.7	21.2	23.1	23.6
EER			3.98	3.48	3.77	3.61	3.48	2.90	3.36	3.19	3.01	2.90	
COP			4.00	3.72	3.89	3.80	3.72	3.79	3.80	3.81	3.77	3.79	
Maximum number of connectable indoor units			21	28	34	39	43	47	52	56	60	64	
Indoor index connection	Min.		140	180	230	250	270	318	356	372	408	424	
	Nom.		280	360	500		540	636	712	744	816	848	
	Max.		364	468	598	650	702	827	926	967.0	1,061	1,102	
Sound pressure level	Cooling	Nom.	dB(A)	57	61		62	63	64	63	64	65	66
Piping connections	Liquid	OD	mm	9.52	12.7		15.9			19.1			
	Gas	OD	mm	22.2	25.4	28.6			34.9				
	Discharge gas	OD	mm	19.1		22.2			25.4		28.6		
	Total piping length	System	Actual	m									300
Current - 50Hz	Maximum fuse amps (MFA)	A	30	40	50	60	70	80	90				

Outdoor unit module		RQEQ	140P		180P		212P				
Dimensions	Unit	HeightxWidthxDepth	mm								
Weight	Unit		175						179		
Fan	Air flow rate	Cooling	Nom.	95		110					
Sound power level	Cooling	Nom.	dB(A)								
Sound pressure level	Cooling	Nom.	54		58		60				
Operation range	Cooling	Min.~Max.	°CDB								
	Heating	Min.~Max.	°CWB								
Refrigerant	Type / GWP		R-410A / 2,087.5								
	Charge	kg/TCO _{Eq}	10.3/21.5		10.6/22.1			11.2/23.4			
Power supply	Phase/Frequency/Voltage		Hz/V								
Current - 50Hz	Maximum fuse amps (MFA)	A	15		20			22.5			

(1) Not Eurovent certified

Replacement VRV



RXYQQ8-12T

Outdoor system				RXYQQ	RQYQ140P	8T	10T	12T	14T	16T	18T	20T	22T	24T	
System	Outdoor unit module 1												RXYQQ10T	RXYQQ8T	
	Outdoor unit module 2												RXYQQ12T	RXYQQ16T	
Capacity range			HP	5	8	10	12	14	16	18	20	22	24		
Cooling capacity	Nom.		kW	14.0	22.4	28.0	33.5	40.0	45.0	50.4	56.0	61.5	67.4		
Heating capacity	Max.		kW	16.0	25.0	31.5	37.5	45.0	50.0	50.4	63.0	69.0	75.0		
Power input - 50Hz	Cooling	Nom.	kW	3.36	5.21	7.29	8.98	11.0	13.0	15.0	18.5	16.27	18.21		
	Heating	Max.	kW	3.91	5.51	7.38	9.10	11.2	12.8	12.6	17.0	16.48	18.31		
EER				4.17	4.30	3.84	3.73	3.64	3.46	3.36	3.03	3.78	3.70		
ESEER				-	6.37 (1)/7.53 (2)	5.67 (1)/7.20 (2)	5.50 (1)/6.96 (2)	5.31 (1)/6.83 (2)	5.05 (1)/6.50 (2)	4.00 (1)/3.87 (2)	4.42 (1)/5.67 (2)	5.58 (1)/7.07 (2)	5.42 (1)/6.81 (2)		
COP				4.09	4.54	4.27	4.12	4.02	3.91	4.97	3.71	4.19	4.10		
Maximum number of connectable indoor units				10	64 (3)								64 (3)		
Indoor index connection	Min.			62.5	100	125	150	175	200	225	250	275	300		
	Nom.			125	200	250	300	350	400	450	500	550	600		
	Max.			162.5	260	325	390	455	520	585	650	715	780		
Dimensions	Unit	HeightxWidthxDepth	mm	1,680x635x765				1,685x930x765				1,685x1,240x765			
Weight	Unit		kg	175	187	194	305			314					
Fan	Air flow rate	Cooling	Nom.	m ³ /min	95	162	175	185	223	260	251	261	-		
Sound power level	Cooling	Nom.	dB(A)	-	78	79	81			86			88		
Sound pressure level	Cooling	Night Quiet Mode	Level	Cooling	54.0	58		61			64	65	66	-	
				Level 1	56	58	58	58	58	60	60	-			
				Level 2	55	54	54	52	52	52	52	-			
				Level 3	53	52	52	47	47	48	48	-			
Operation range	Cooling	Min.~Max.	°CDB	-5~43								-			
	Heating	Min.~Max.	°CWB	-20~15.5								-			
Refrigerant	Type / GWP			R-410A / 2,087.5											
	Charge		kg/TCO,Eq	11.1/23.2	5.9/12.3	6/12.5	6.3/13.2	10.3/21.5	10.4/21.7	11.7/24.4	11.8/24.6	-			
Piping connections	Liquid	OD	mm	9.52	9.52			12.7				15.9			
	Gas	OD	mm	15.9	19.1	22.2	28.6					34.9			
	Total piping length	System	Actual	m	300	300							-		
Power supply	Phase/Frequency/Voltage		Hz/V	3N~/50/380-415										-	
Current - 50Hz	Maximum fuse amps (MFA)			A	15	20	25	32			40	50	63		

Outdoor system				RXYQQ	26T	28T	30T	32T	34T	36T	38T	40T	42T
System	Outdoor unit module 1				RXYQQ12T			RXYQQ16T			RXYQQ8T	RXYQQ10T	
	Outdoor unit module 2			RXYQQ14T	RXYQQ16T	RXYQQ18T	RXYQQ16T	RXYQQ18T	RXYQQ20T	RXYQQ10T	RXYQQ12T	RXYQQ16T	
	Outdoor unit module 3									RXYQQ20T	RXYQQ18T	RXYQQ16T	
Capacity range			HP	26	28	30	32	34	36	38	40	42	
Cooling capacity	Nom.		kW	73.5	78.5	83.5	90.0	95.0	101.0	106.4	111.5	118.0	
Heating capacity	Max.		kW	82.5	87.5	93.5	100.0	106.0	113.0	119.5	125.0	131.5	
Power input - 50Hz	Cooling	Nom.	kW	19.98	21.98	23.68	26.0	27.7	31.5	31.00	30.97	33.29	
	Heating	Max.	kW	20.30	21.90	23.50	25.6	27.2	29.8	29.89	30.88	32.98	
EER				3.68	3.57	3.53	3.5	3.4	3.2	3.43	3.60	3.54	
ESEER				5.39 (1)/6.89 (2)	5.23 (1)/6.69 (2)	5.17 (1)/6.60 (2)	5.05 (1)/6.50 (2)	5.01 (1)/6.44 (2)	4.68 (1)/6.02 (2)	5.03 (1)/6.36 (2)	5.29 (1)/6.74 (2)	5.19 (1)/6.65 (2)	
COP				4.06	4.00	3.98	3.9		3.8	4.00	4.05	3.99	
Maximum number of connectable indoor units					64 (3)								
Indoor index connection	Min.			325	350	375	400	425	450	475	500	525	
	Nom.			650	700	750	800	850	900	950	1,000	1,050	
	Max.			845	910	975	1,040	1,105	1,170	1,235	1,300	1,365	
Sound power level	Cooling	Nom.	dB(A)	-									
Sound pressure level	Cooling	Nom.	dB(A)	-									
Piping connections	Liquid	OD	mm	19.1									
	Gas	OD	mm	34.9					41.3				
	Total piping length	System	Actual	m	300							100	
Current - 50Hz	Maximum fuse amps (MFA)			A	63			80			100		

(1) The STANDARD ESEER value corresponds with normal VRV4 Heat Pump operation, not taking into account advanced energy saving operation functionality (2) The AUTOMATIC SEER value corresponds with normal VRV4 Heat Pump operation, taking into account advanced energy saving operation functionality (variable refrigerant temperature control operation) (3) Actual number of connectable indoor units depends on the indoor unit type (VRV indoor, Hydrobox, RA indoor, etc.) and the connection ratio restriction for the system (50% ≤ CR ≤ 130%) (4) Not Eurovent certified

RQCEQ280-360P

RQCEQ280-360P

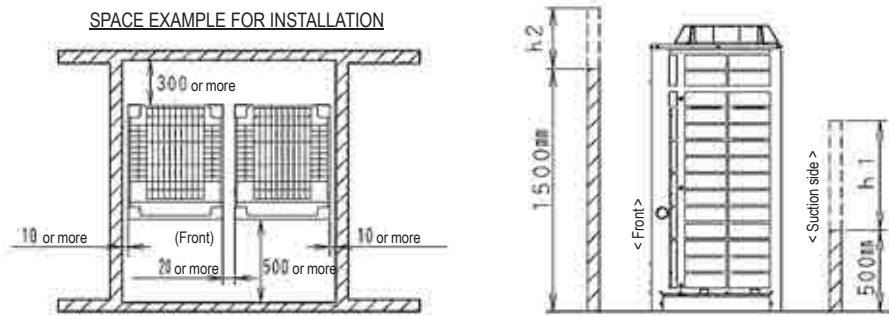
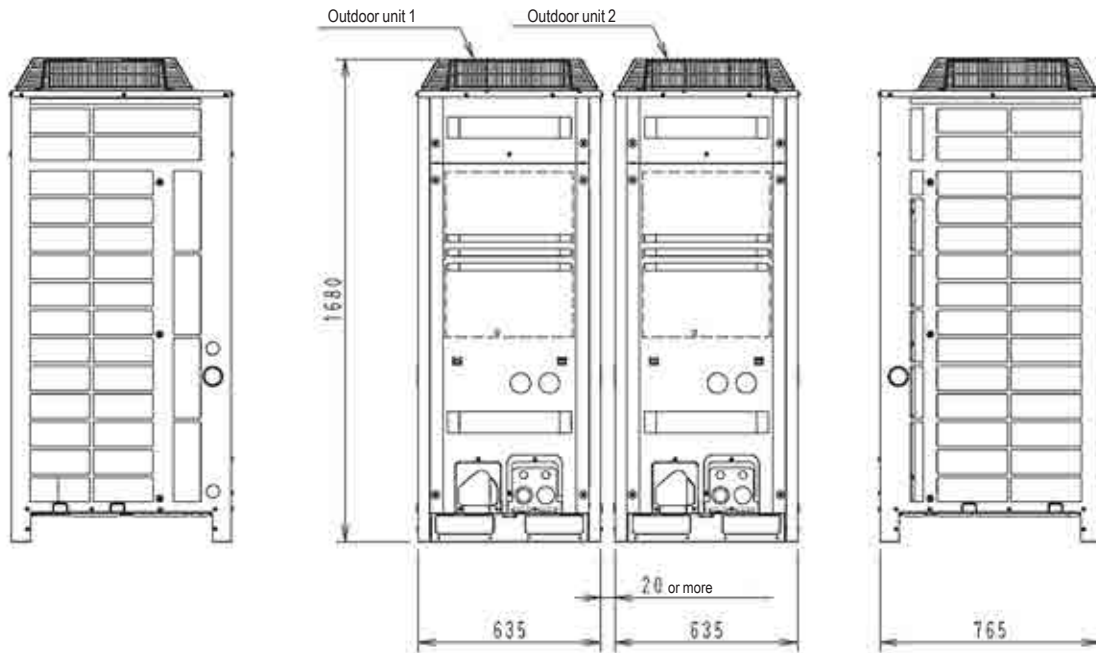
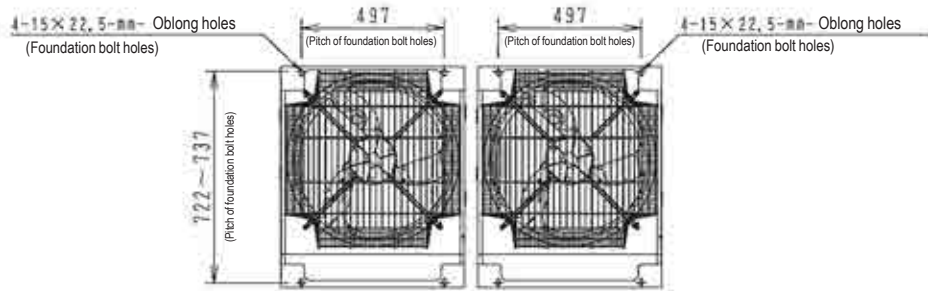

Model name	Outdoor unit 1	Drawing N°.	Outdoor Unit 2	Drawing N°.
RQCEQ280P	RQE140P	3D066441	RQE140P	3D066441
RQCEQ360P	RQE180P	3D066441	RQE180P	3D066441

Unit:mm

NOTES

- Heights of walls
 Front: 1500mm
 Suction side: 500mm
 Side: Height unrestricted
 The installation space shown in this figure is based on the condition of cooling operation at the outdoor air temperature of 35°C.
 The installation space of suction side shown above must be expanded in the following case.
 - Design outdoor temperature becomes over 35°C.
 - Operating over Max. operating load
 (In case of causing a heavy heating load at indoor unit side)
- If the above wall heights are exceeded then h2/2 and h1/2 should be added to the front and suction side service spaces respectively as shown in the following figure.
- When installing the units the most appropriate pattern should be selected from those shown above in order to obtain the best fit in the space available always bearing in mind the need to leave enough room for a person to pass between units and wall for the air to circulate freely. (If more units are to be installed than are catered for in the above patterns your layout should take account of the possibility of short circuits.)
- The units should be installed to leave sufficient space at the front for the on site refrigerant piping work to be carried out comfortably.

3D066856

RQCEQ460-636P

RQCEQ460-636P

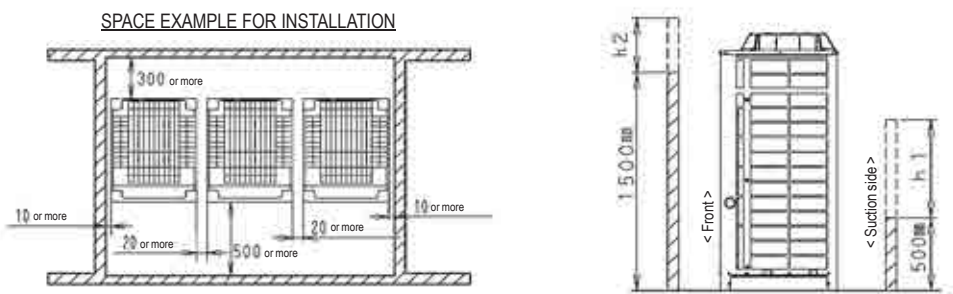
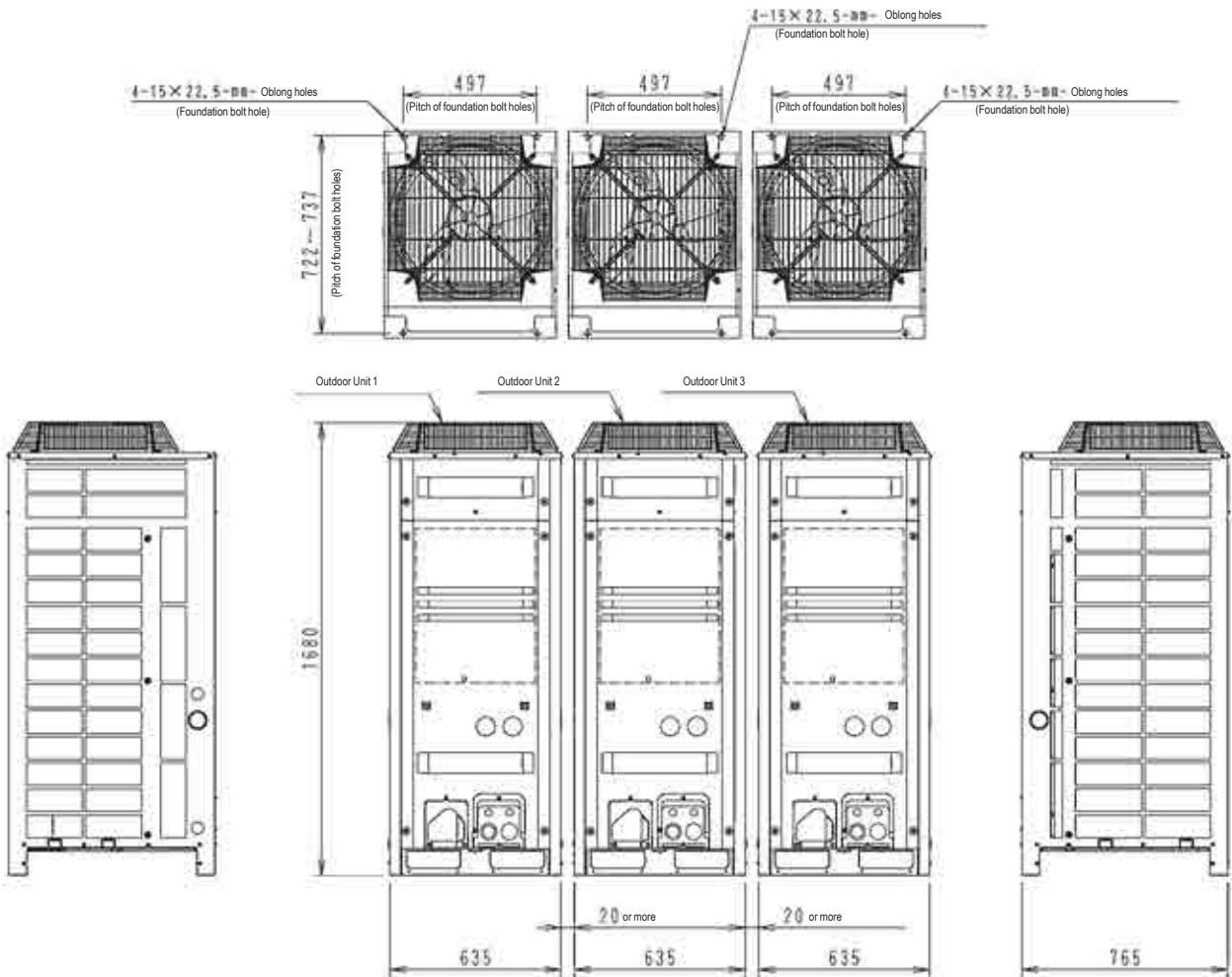

Unit:mm

Model name	Outdoor unit 1	Drawing N°	Outdoor Unit 2	Drawing N°	Outdoor unit 1	Drawing N°
RQCEQ460P	RQEQ180P	3D066441	RQEQ140P	3D066441	RQEQ140P	3D066441
RQCEQ500P	RQEQ180P	3D066441	RQEQ180P	3D066441	RQEQ140P	3D066441
RQCEQ540P	RQEQ180P	3D066441	RQEQ180P	3D066441	RQEQ180P	3D066441
RQCEQ636P	RQEQ212P	3D066441	RQEQ212P	3D066441	RQEQ212P	3D066441

NOTES

- Heights of walls
 Front: 1500mm
 Suction side: 500mm
 Side: Height unrestricted
 The installation space shown in this figure is based on the condition of cooling operation at the outdoor air temperature of 35°C.
 The installation space of suction side shown above must be expanded in the following case.
 - Design outdoor temperature becomes over 35°C.
 - Operating over Max. operating load
 (In case of causing a heavy heating load at indoor unit side)
- If the above wall heights are exceeded then h/2 and h/2 should be added to the front and suction side service spaces respectively as shown in the following figure.
- When installing the units the most appropriate pattern should be selected from those shown above in order to obtain the best fit in the space available always bearing in mind the need to leave enough room for a person to pass between units and wall for the air to circulate freely. (If more units are to be installed than are catered for in the above patterns your layout should take account of the possibility of short circuits.)
- The units should be installed to leave sufficient space at the front for the on site refrigerant piping work to be carried out comfortably.

3D066860

RQCEQ721-848P

RQCEQ712-848P

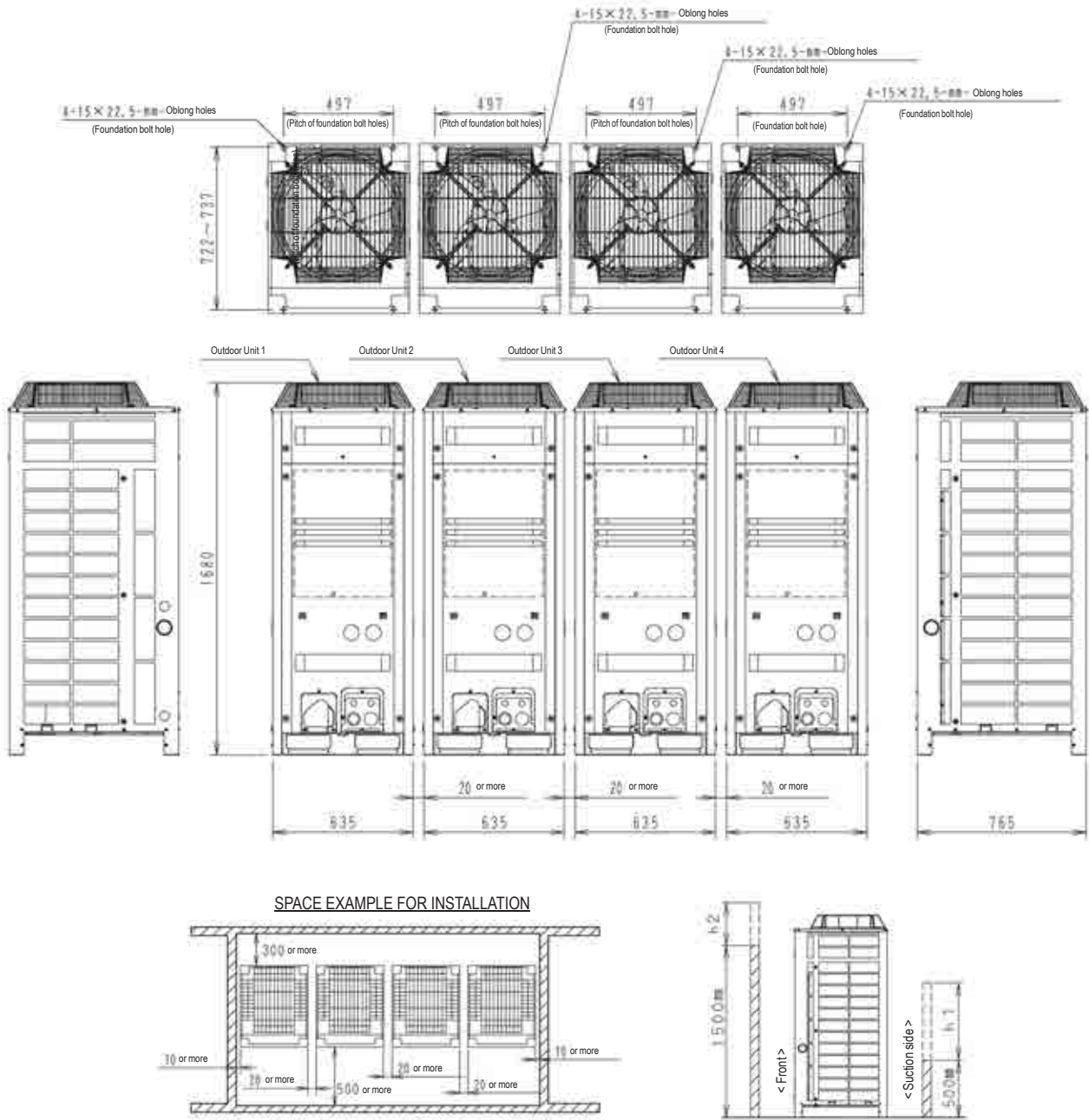

Unit: mm

Model name	Outdoor unit 1	Drawing N°.	Outdoor Unit 2	Drawing N°.	Outdoor unit 3	Drawing N°.	Outdoor unit 4	Drawing N°.
RQCEQ712P	RQEQ212P	3D066441	RQEQ180P	3D066441	RQEQ180P	3D066441	RQEQ140P	3D066441
RQCEQ744P	RQEQ212P	3D066441	RQEQ212P	3D066441	RQEQ180P	3D066441	RQEQ140P	3D066441
RQCEQ816P	RQEQ212P	3D066441	RQEQ212P	3D066441	RQEQ212P	3D066441	RQEQ180P	3D066441
RQCEQ848P	RQEQ212P	3D066441	RQEQ212P	3D066441	RQEQ212P	3D066441	RQEQ212P	3D066441

NOTES

- Heights of walls
 Front: 1500mm
 Suction side: 500mm
 Side: Height unrestricted
 The installation space shown in this figure is based on the condition of cooling operation at the outdoor air temperature of 35°C.
 The installation space of suction side shown above must be expanded in the following case.
 - Design outdoor temperature becomes over 35°C.
 - Operating over Max. operating load
 (In case of causing a heavy heating load at indoor unit side)
- If the above wall heights are exceeded then h2/2 and h1/2 should be added to the front and suction side service spaces respectively as shown in the following figure.
- When installing the units the most appropriate pattern should be selected from those shown above in order to obtain the best fit in the space available always bearing in mind the need to leave enough room for a person to pass between units and wall for the air to circulate freely. (If more units are to be installed than are catered for in the above patterns your layout should take account of the possibility of short circuits.)
- The units should be installed to leave sufficient space at the front for the on site refrigerant piping work to be carried out comfortably.

3D066865

RQYQ140P

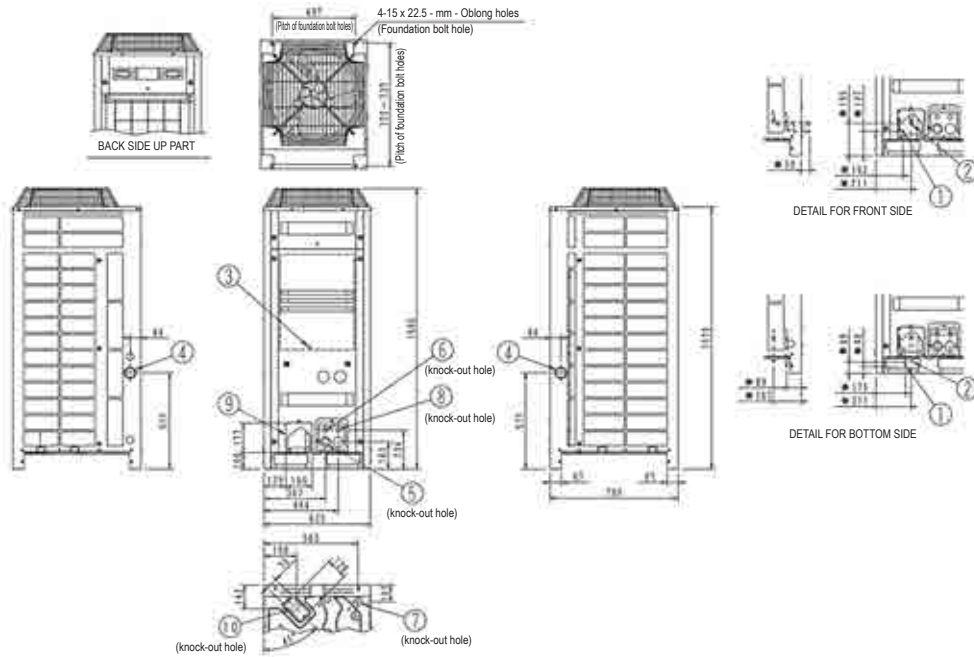

3D066442

No.	Parts name	Remarks
1	Liquid pipe connection port	ø9.5 Brazing connection
2	Gas pipe connection port	See note 3.
3	Grounding terminal	Inside of switch box (M8)
4	Power cord routing hole (side)	ø62
5	Power cord routing hole (front)	ø45
6	Power cord routing hole (front)	ø27
7	Power cord routing hole (bottom)	ø50
8	Wire routing hole (front)	ø27
9	Pipe routing hole (front)	See note 2.
10	Pipe routing hole (bottom)	See note 2.

NOTES

- 1 * shows the dimensions after fixing the accessory pipes.
- 2 For piping connection method (front and bottom sides) see the installation manual.
- 3 Gas pipe
ø15.9 Brazing connection: RQYQ140P

RXYQQ8-12T

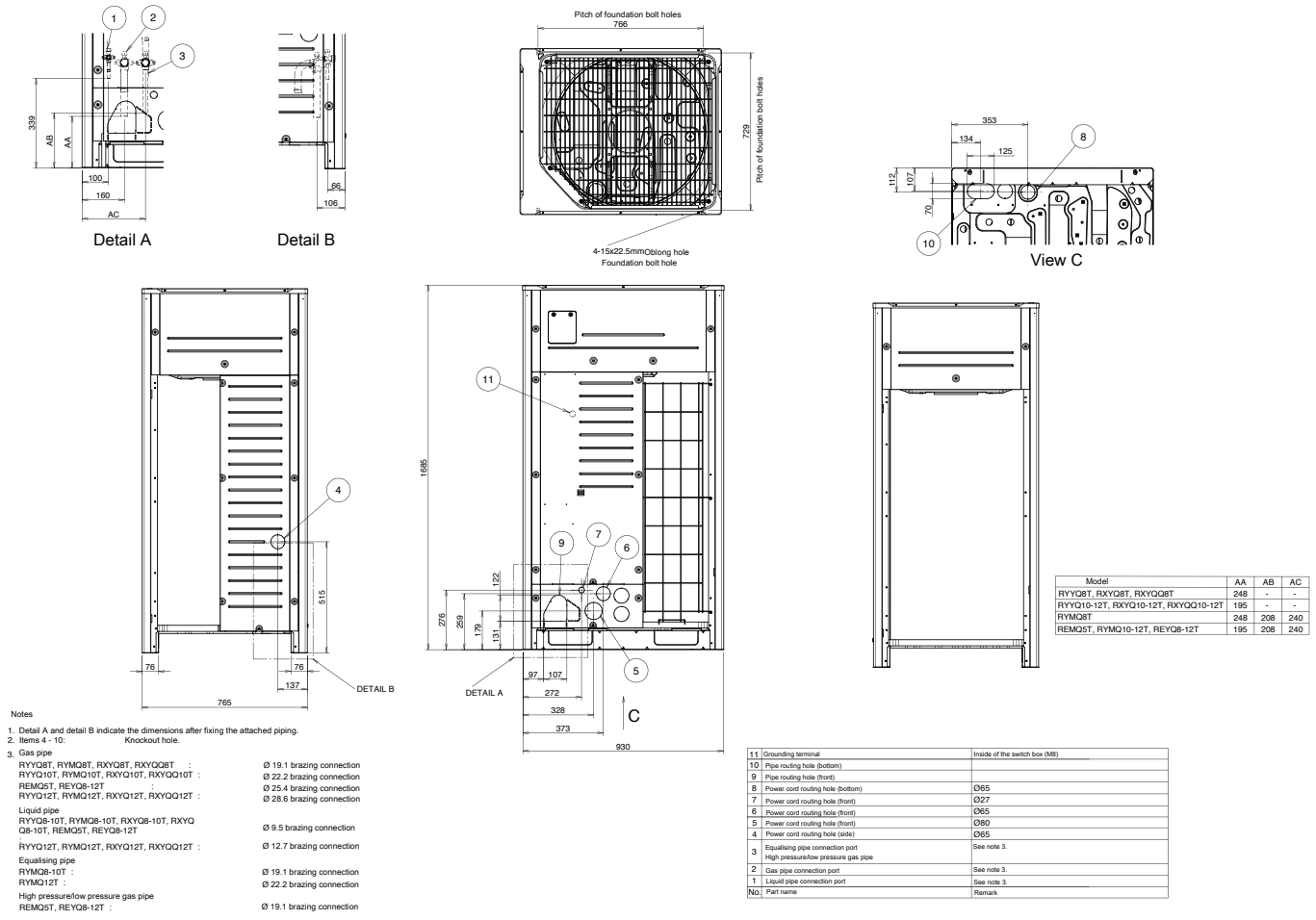

2D079532B

RXYQQ14-20T

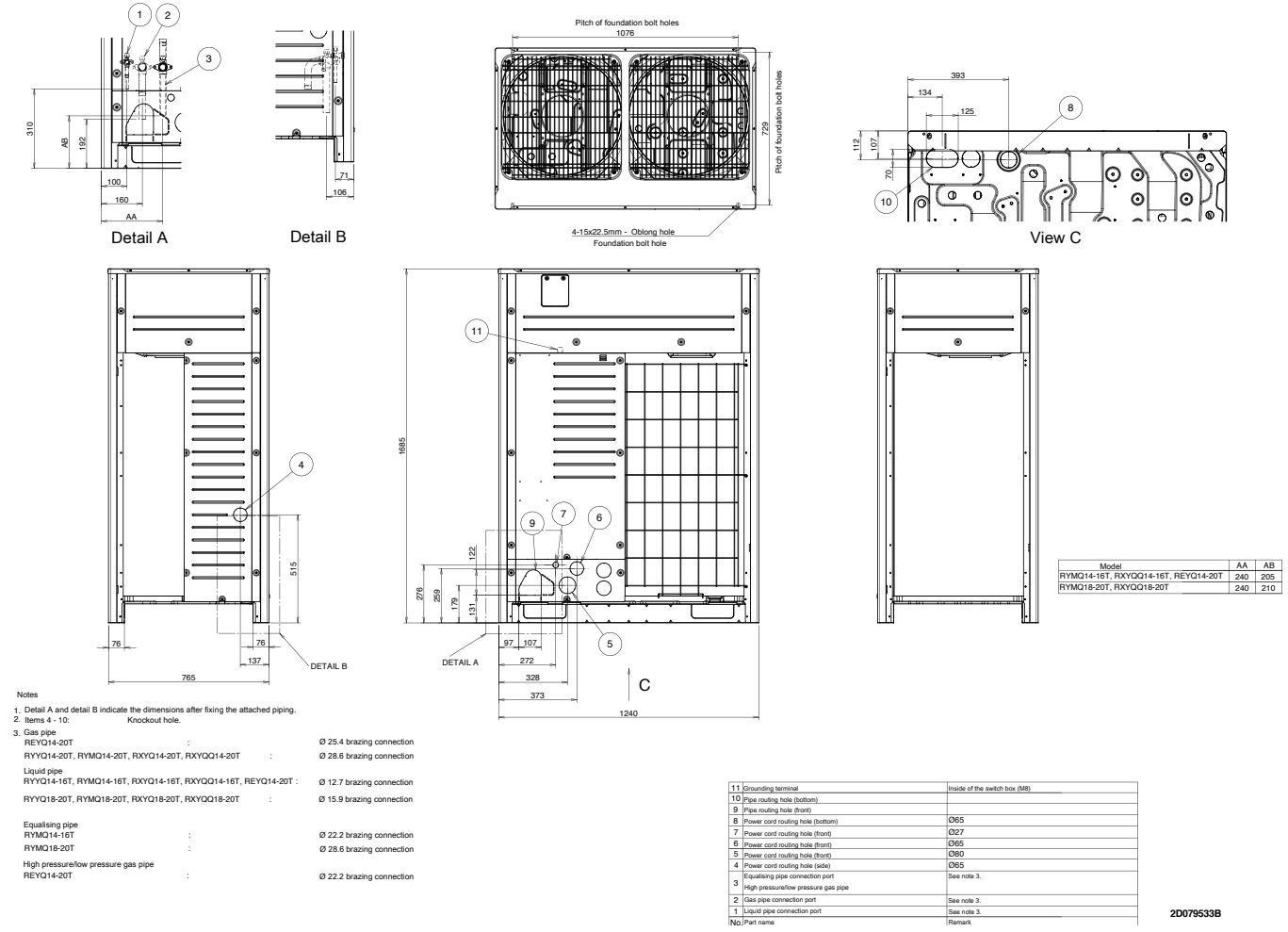

2D079533B

RQYQ140P

RQYQ140P

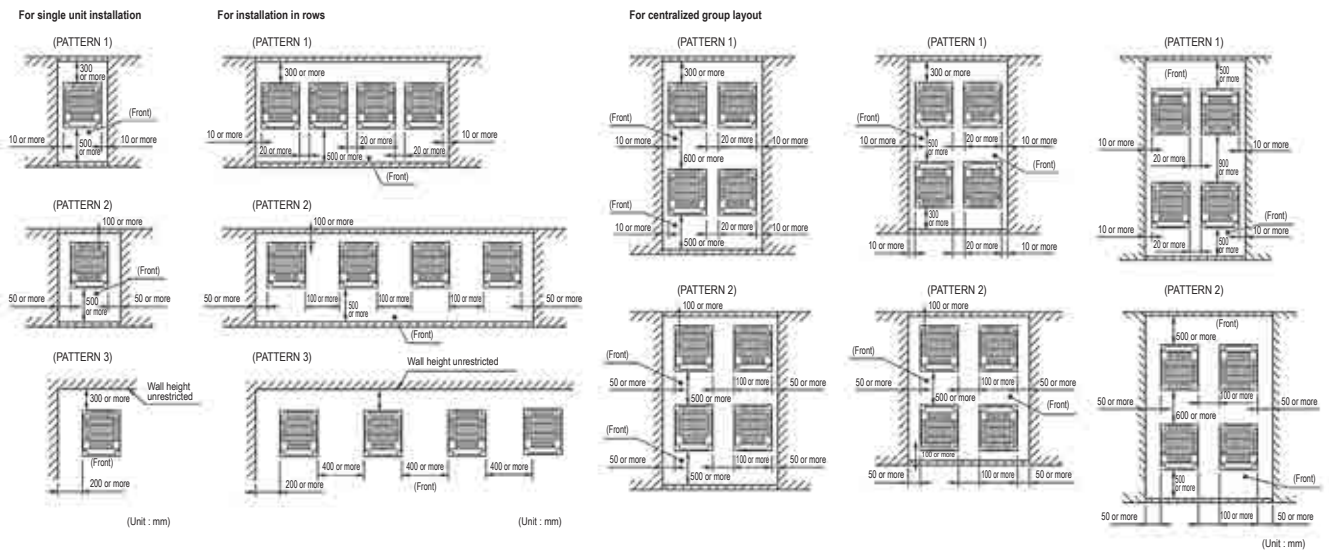

3D066327

NOTES

- Heights of walls in case of patterns 1 and 2: Front: 1500mm. Suction side: 500 mm. Side: Height unrestricted. Installation space to be shown in this drawing is based on the cooling operation at 35 degrees outdoor air temperature. When the design outdoor air temperature exceeds 35 degrees or the load exceeds maximum ability because of much generation load heat in all outdoor unit, take the suction side space more broadly than the space to be shown in this drawing.
- If the above wall heights are exceeded then h2/2 and h1/2 should be added to the front and suction side service spaces respectively as shown in the figure on the right.
- When installing the units the most appropriate pattern should be selected from those shown above in order to obtain the best fit in the space available always bearing in mind the need to leave enough room for a person to pass between units and wall and for the air to circulate freely. (If more units are to be installed than are catered for in the above patterns your layouts should take account of the possibility of short circuits.)
- The units should be installed to leave sufficient space at the front for the on site refrigerant piping work to be carried out comfortably.

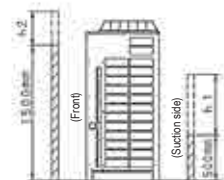

RXYQQ-T

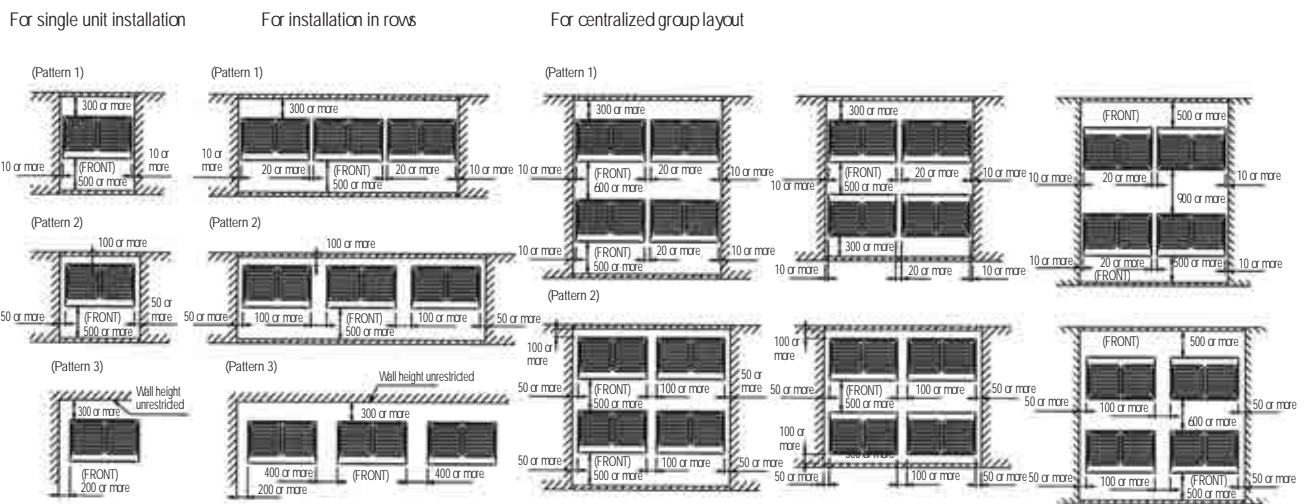

NOTES

- Heights of walls in case of patterns 1 and 2:
Front: 1500mm
Suction side: 500mm
Side: Height unrestricted
Installation space as shown on this drawing is based on the cooling operation at 35 degrees outdoor air temperature. When the design outdoor air temperature exceeds 35 degrees or the load exceeds maximum ability of much generation load of heat in all outdoor unit, take the suction side space more broadly than the space as shown on this drawing.
- If the above wall heights are exceeded then h2/2 and h1/2 should be added to the front and suction side service spaces respectively as shown in the figure on the right.
- When installing the units most appropriate pattern should be selected from those shown above in order to obtain the best fit in the space available. Always keep in mind the need to leave enough space for a person to pass between units and wall and also for the air to circulate freely. (If more units are to be installed than are catered for in the above patterns your layout should take account of the possibility of short circuits.)
- The units should be installed to leave sufficient space at the front for the on site refrigerant piping work to be carried out comfortably.

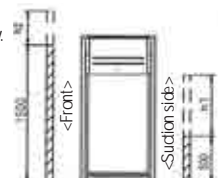

Water cooled VRV IV W-series

Ideal for high rise buildings,
using water as heat source

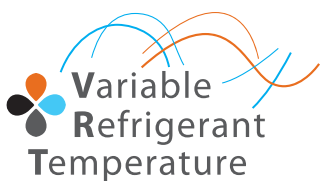

VRV IV standards: Variable refrigerant temperature

Customize your VRV for best seasonal efficiency & comfort

- › Full inverter compressors
- › Reluctance brushless DC compressor
- › Sine wave DC inverter
- › Manual demand function
- › Geothermal operation

For more information on these features refer to the VRV IV technologies tab





Geothermal operation and advantages

Geothermal operation uses the more stable temperature of the ground around the building, eliminating the need for another heat source. It reduces CO₂ emissions and is an infinitely renewable energy source.

Efficiency not influenced by outdoor conditions

The water cooled VRV unit operates at a superior efficiency, even in the most extreme outdoor temperatures thanks to geothermal operation.

Because the temperature of ground water, lakes and rivers, remains relatively constant the year round, our water-cooled system maintains its superior efficiency, even in the most extreme outdoor temperatures, when the efficiency of air-cooled systems goes down.



Wide operation range

Standard water cooled outdoor units have a wide operation range between 10°C & 45°C inlet water temperature, both in heating and cooling. In geothermal mode the operation range is extended even more, down to -10°C* in heating and 6°C in cooling mode.

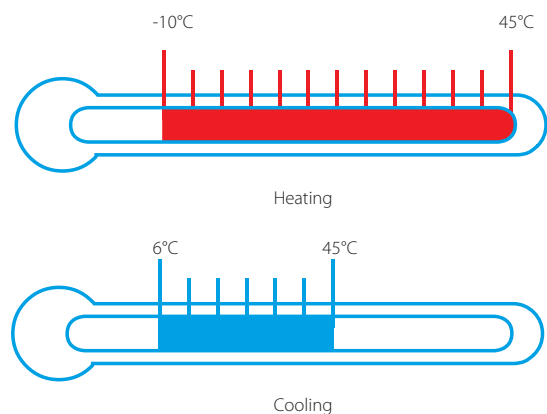

* Ethylene glycol should be added to the water when the water inlet temperature is below 5°C

High energy efficiencies results from 2-stage heat recovery

Stage 1: Heat recovery between indoor units in the same refrigerant circuit

Heat exhausted from indoor units in cooling mode is transferred to units in areas requiring heating, maximising energy efficiency and reducing electricity costs.

Stage 2: Heat recovery between the outdoor units via the water loop - also available on heat pump units!

Second stage heat recovery is achieved within the water loop between the water cooled outdoor units.

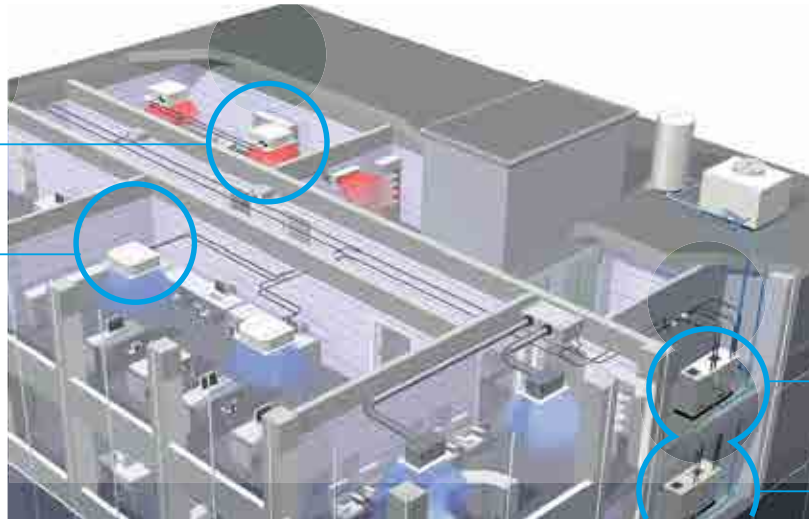

stage 1

stage 2

Heat recovery between indoor units

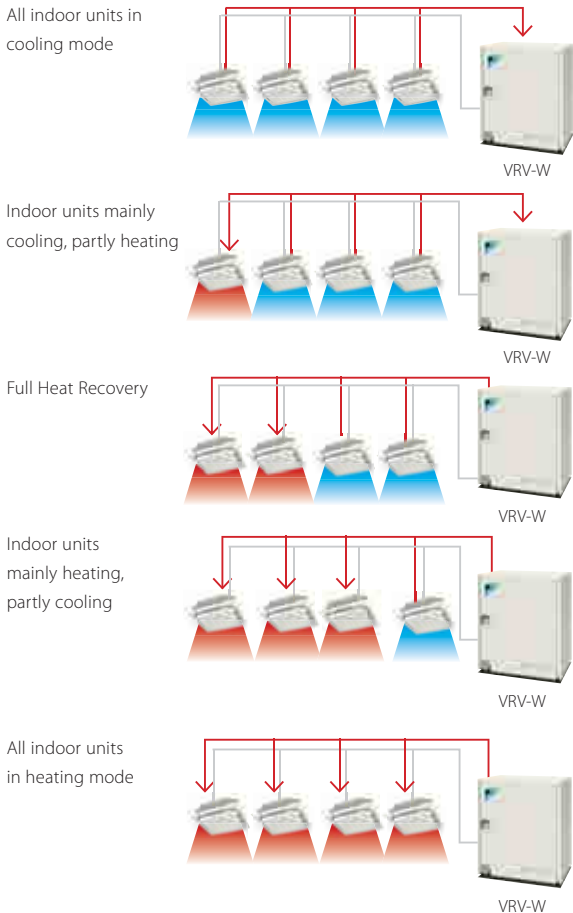

Heat recovery between outdoor units

(Heat recovery and heat pump)

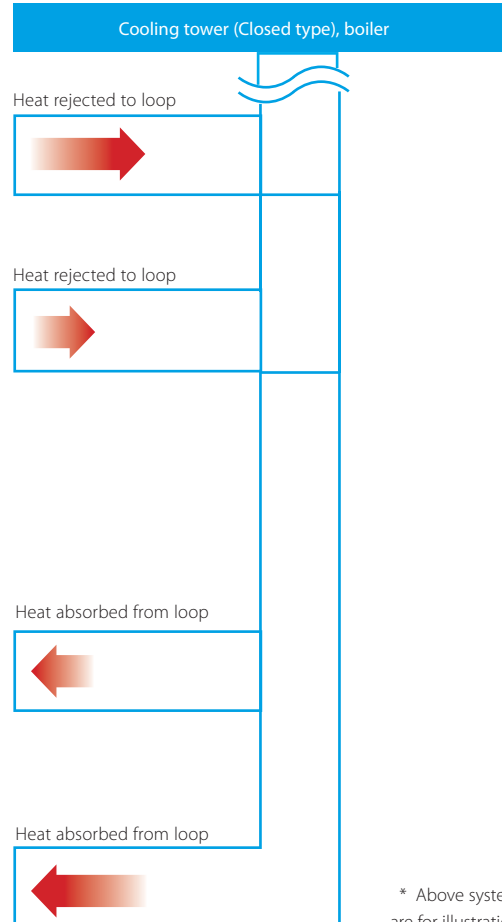

* Above system configurations are for illustration purposes only.

Space saving - Stacked configuration

The adoption of a new water heat exchanger and optimization of the refrigerant control circuit has resulted in the industry's most compact and lightweight design. The unit weight of 149kg* and height of 1,000 mm makes installation easy. Stacked configuration is also possible, contributing further to space savings.

* for 8HP unit

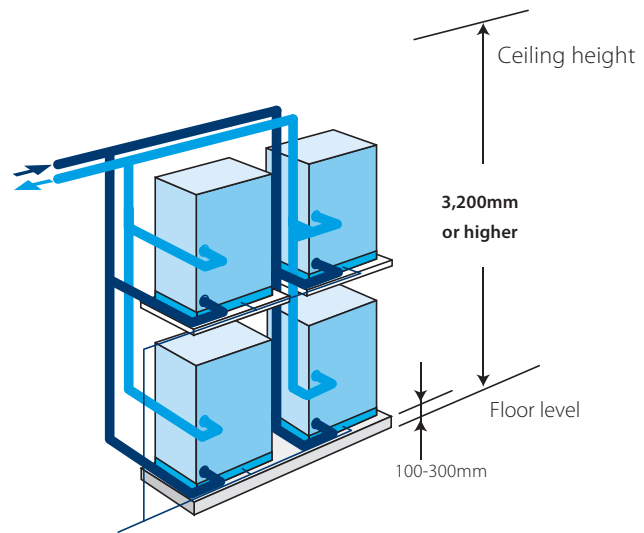

Stacked configuration is possible.

Variable water flow control

The variable water flow control option reduces energy use by the circulation pump by reducing the water flow when possible and not using a fixed water flow all the time.

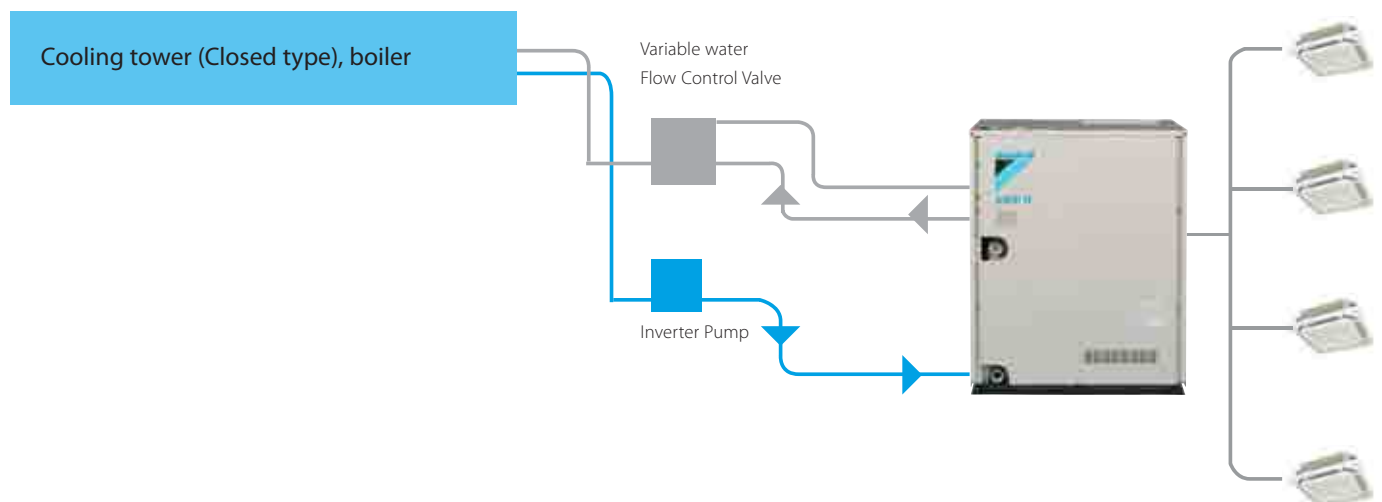

Standard water strainer

A standard water strainer reduces installation time. The new filter also has less pressure drop at higher water flows.

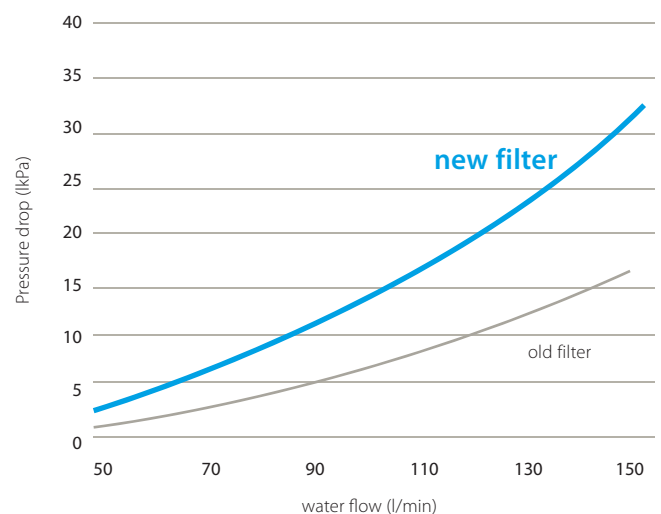

Flexible piping design

Flexible water piping

Water cooled VRV uses water as its heat source, so it is optimal for large buildings, including tall, multi-storey buildings, because the system can tolerate water pressure of up to 1.96 MPa.

Furthermore, if the currently installed heat source's water temperature is between 10°C and 45°C, it may be possible to use the existing water pipe work and heat source. This alone makes it an ideal system solution for building refurbishment projects.

Total piping length	300m
Longest length actual (Equivalent)	120m (140m)
Longest length after first branch	40m (90m ¹)
Level difference between indoor and outdoor units	50m (40m ²)
Level difference between indoor units	15m

1 Contact your local dealer for more information and restrictions
2 In case outdoor unit is located below indoor units

Actual piping length between the VRV-W and indoor units: 120m (Equivalent piping length: 140m)

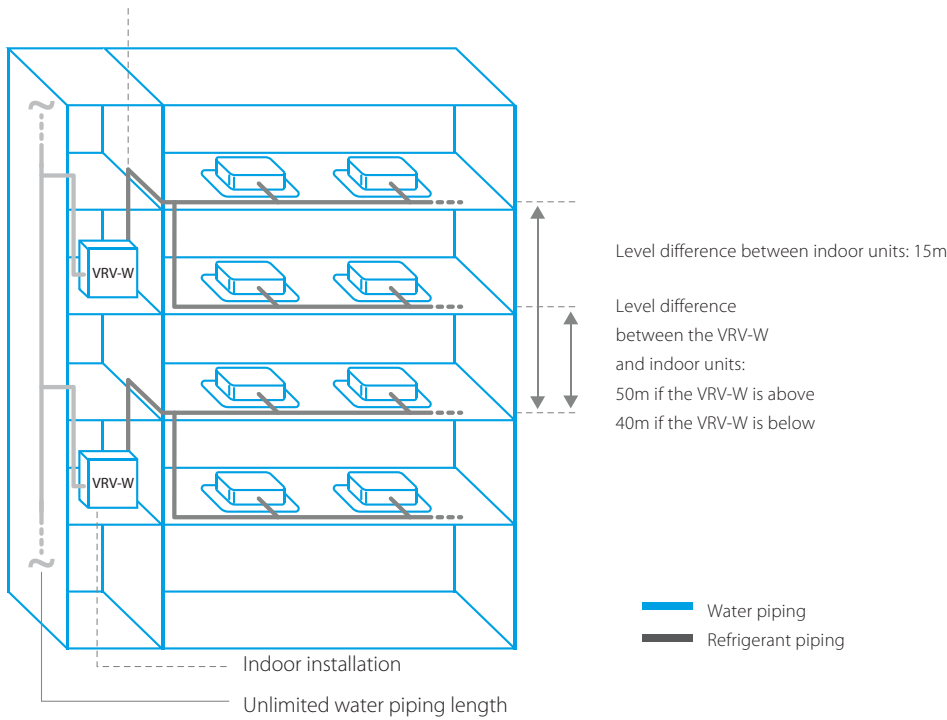

Park Phi, Enschede - The Netherlands

BREEAM excellent office building

For Gerard Schröder the choice for this system was an easy one: 'As far as I'm concerned, with the VRV Heat Recovery system, Daikin has the Rolls Royce in heat pump technology. If you want to build a sustainable office building, there really is no other alternative.'



VRV-WIII geothermal system, Daikin Altherma HT, Sky Air, aircooled chiller with heat recovery, iManager, iTouch Manager, ACNSS



PARK PHI
BREAAAM® EXCELLENT OFFICE
BUILDING
WATERCOOLED VRV

VRV IV water cooled series

Ideal for high rise buildings, using water as heat source

- › Unified range for standard and geothermal series simplifies stock. Geothermal series reduce CO₂ emissions thanks to the use of geothermal energy as a renewable energy source
- › No need for an external heating or cooling source when used in geothermal mode
- › Covers all thermal needs of a building via a single point of contact: accurate temperature control, ventilation, hot water, air handling units and Biddle air curtains
- › Compact & lightweight design can be stacked for maximum space saving
- › Incorporates VRV IV standards & technologies: Variable Refrigerant Temperature and full inverter compressors
- › 2-stage heat recovery: first stage between indoor units, second stage between outdoor units thanks to the storage of energy in the water circuit
- › Available in heat pump and heat recovery version
- › Variable Water Flow control option increases flexibility and control
- › Easy compliance with F-gas regulation thanks to automated refrigerant containment check
- › Contains all standard VRV features

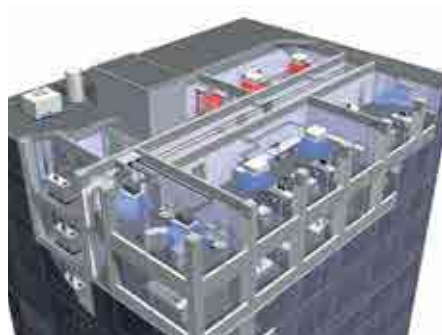

Standard operation



Geothermal operation

Outdoor unit		RWEYQ	8T	10T	16T	18T	20T	24T	26T	28T	30T	
System	Outdoor unit module 1		RWEYQ8T	RWEYQ10T	RWEYQ8T		RWEYQ10T	RWEYQ8T		RWEYQ10T		
	Outdoor unit module 2		-		RWEYQ8T	RWEYQ10T		RWEYQ8T		RWEYQ10T		
	Outdoor unit module 3		-		-		RWEYQ8T	RWEYQ8T		RWEYQ10T		
Capacity range		HP	8	10	16	18	20	24	26	28	30	
Cooling capacity	Nom.	kW	22.4	28.0	44.8	50.4	56.0	67.2	72.8	78.4	84.0	
Heating capacity	Nom.	kW	25.0	31.5	50.0	56.5	63.0	75.0	81.5	88.0	94.5	
Power input - 50Hz	Cooling	Nom.	kW	4.42	6.14	8.8	10.6	12.3	13.3	15.0	16.7	18.4
	Heating	Nom.	kW	4.21	6.00	8.4	10.2	12.0	12.6	14.4	16.2	18.0
EER			5.07	4.56	5.07	4.77	4.56	5.07	4.86	4.69	4.56	
COP			5.94	5.25	5.94	5.53	5.25	5.94	5.65	5.43	5.25	
Maximum number of connectable indoor units			36									
Indoor index connection	Min.		100	125	200	225	250	300	325	350	375	
	Nom.		200	250	400	450	500	600	650	700	750	
	Max.		260	325	520	585	650	780	845	910	975	
Dimensions	Unit	HeightxWidthxDpeth	mm		1,000x780x550						-	
Weight	Unit		kg		137						-	
Fan	Air flow rate	Cooling	Nom.	m ³ /min		-						
Sound power level	Cooling	Nom.	dBA		-							
Sound pressure level	Cooling	Nom.	dBA		50	51	53	54	55	56		
Operation range	Inlet water temperature	Cooling	Min.-Max.	°CDB		10~45						
		Heating	Min.-Max.	°CWB		-10 / 10.0~45						
Refrigerant	Type / GWP	R-410A / 2,087.5										
	Charge	kg/TCO _{Eq}	3.5/7.3	4.2/8.8	-	-	-	-	-	-	-	
Piping connections	Liquid	OD	mm		9.52		12.7		15.9		19.1	
		Gas	OD	mm		19.10 (1)		22.2 (1)		28.6 (1)		34.9 (1)
	Discharge gas	OD	mm		15.9 (2) / 19.10 (3)		19.1 (2) / 22.10 (3)		22.2 (2) / 28.60 (3)		28.6 (2) / 34.90 (3)	
		Water	Inlet/Outlet	PT1 1/4B internal thread/PT1 1/4B internal thread								
	Total piping length	System	Actual	m		300						
Power supply	Phase/Frequency/Voltage	Hz/V		3N~/50/380-415								
Current - 50Hz	Maximum fuse amps (MFA)	A	20		32				50			

(1) In case of heat pump system, gas pipe is not used (2) In case of heat recovery system (3) In case of heat pump system (4) Not Eurovent certified

RWEYQ-T

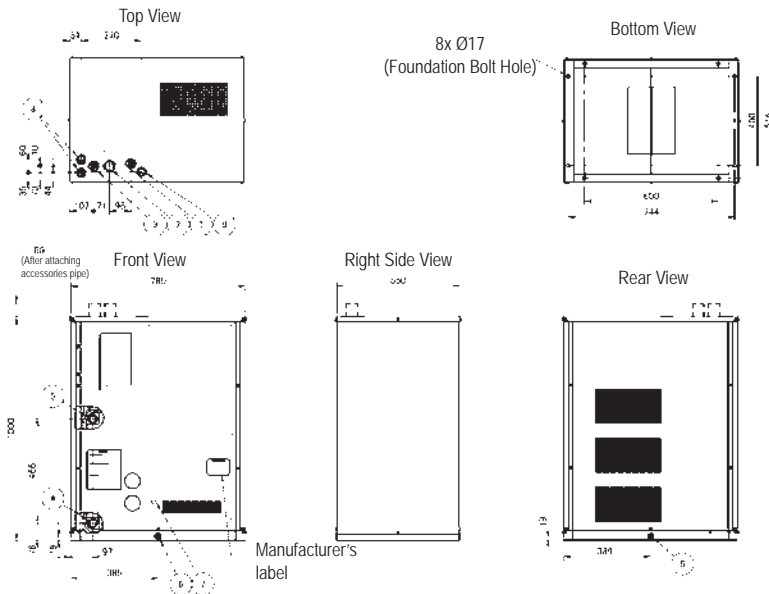

3D085178

Item	Part Name	Remark
1	Liquid Pipe	See note 2
2	Suction Gas Pipe	See note 2
3	HP/LP Gas Pipe	See note 2
4	Water Inlet	PT 1 1/4 B Internal Thread
5	Water Outlet	PT 1 1/4 B Internal Thread
6	Drain Outlet	PS 1/2 B Internal Thread
7	Earth Terminal	M5
8	Power Chord Through Hole	Ø29
9	Wiring Through Hole	Ø29
10	Pipe routing hole (bottom)	
11	Grounding terminal	Inside of switch box (M8)

NOTES

1. Earth terminal is in the switch box
2. Piping size is as follows

MODEL NAME	RWEYQ8		RWEYQ10	
	Heat Pump	Heat Recovery	Heat Pump	Heat Recovery
Liquid Pipe	Ø9.5	Ø9.5	Ø9.5	Ø9.5
Suction Gas Pipe	-	Ø19.1	-	Ø22.2
HP/LP Gas Pipe	Ø19.1	Ø15.9	Ø22.2	Ø19.1

- * Connection method: Liquid Pipe:
 Suction Gas Pipe: } Brazing connection
 HP/LP Gas Pipe: }
- * In case of heat pump, suction gas pipe is not used.

RWEYQ-T

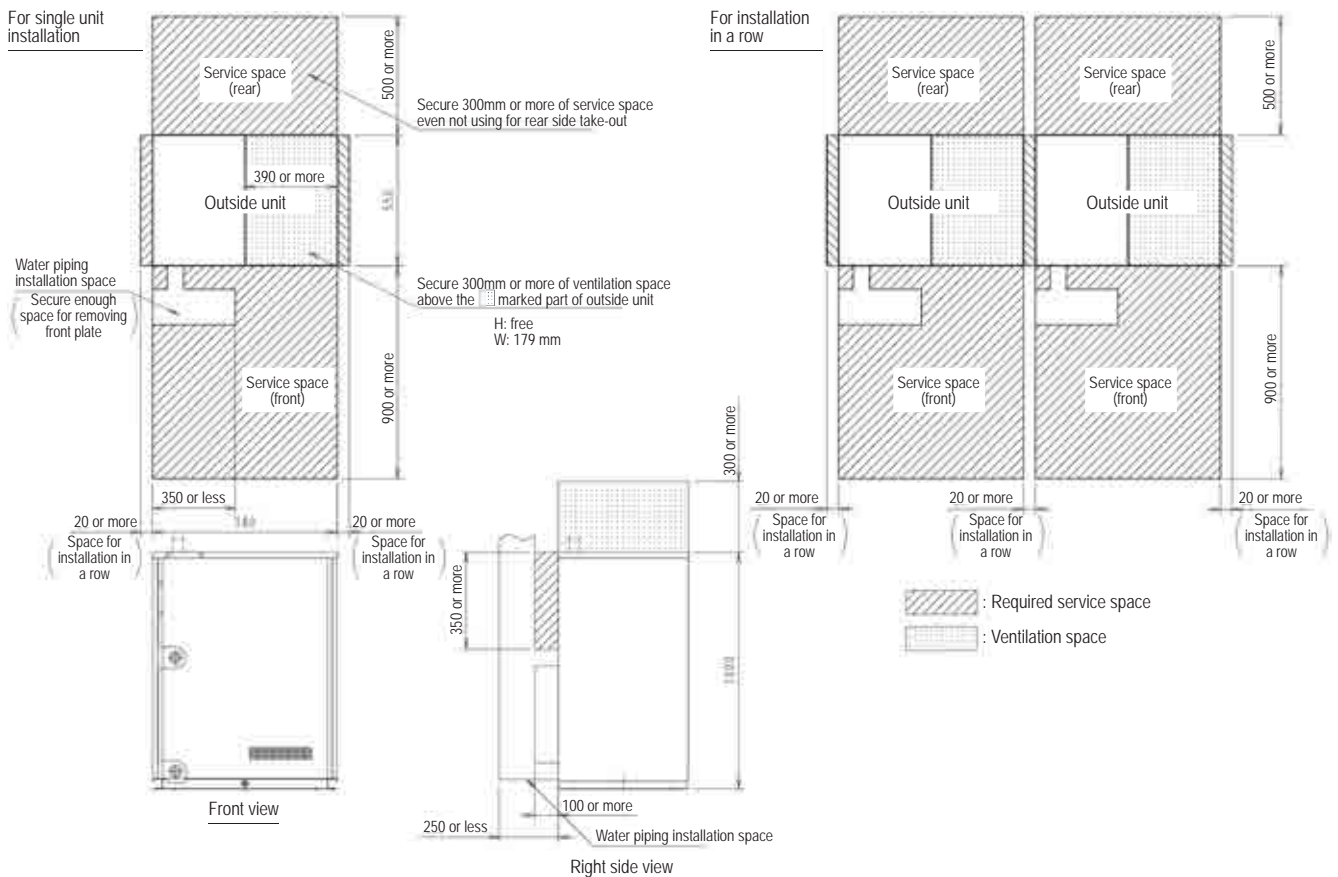



VRV Indoor units

One of the widest ranges on the market, it currently comprises no less than 26 different stylish and elegant models in 116 different variants. All designed to maximise comfort, minimise operating noise and simplify installation and servicing.

VRV Indoor units

VRV indoor units

Ceiling mounted cassette units

FXFQ-A	106
FXZQ-A	110
FXCQ-A	113
FXKQ-MA	116

Concealed ceiling units

FXDQ-M9	118
NEW FXDQ-A	120
FXSQ-A	126
FXMQ-P7 / FXMQ-MA9	128

Wall mounted unit

FXAQ-P	136
--------	-----

Ceiling suspended units

FXHQ-A	140
FXUQ-A	142

NEW Floor standing units

FXNQ-A	144
FXLQ-P	145

Stylish indoor units

BPMKS

Accessory to connect stylish indoor units	149
---	-----

Wall mounted

FTXG-LS/LW	151
CTXS-K / FTXS-K	154

Floor standing

FVXG-K	158
FVXS-F	161

Flexi type unit

FLXS-B(9)	163
-----------	-----



























Indoor Units



Benefits overview

VRV indoor

We care		Inverter technology	In combination with inverter controlled outdoor units
		Home leave operation	During absence, indoor comfort levels can be maintained
		Fan only	The air conditioner can be used as fan, blowing air without cooling or heating
		Auto cleaning filter	The filter automatically cleans itself once a day. Simplicity of upkeep means optimum energy efficiency and maximum comfort without the need for expensive or time-consuming maintenance
		Floor and presence sensor	The presence sensor directs the air away from any person detected in the room. The floor sensor detects the average floor temperature and ensures an even temperature distribution between ceiling and floor
Comfort		Draught prevention	When starting to warm up or when the thermostat is off, the air discharge direction is set horizontally and the fan to low speed, to prevent draught. After warming up, air discharge and fan speed are set as desired
		Whisper quiet	Daikin indoor units are whisper quiet. Also the outdoor units are guaranteed not to disturb the quiet of the neighbourhood
		Auto cooling-heating changeover	Automatically selects cooling or heating mode to achieve the set temperature
Air treatment		Air filter	Removes airborne dust particles to ensure a steady supply of clean air
Humidity control		Dry programme	Allows humidity levels to be reduced without variations in room temperature
Air flow		Ceiling soiling prevention	The air discharge of the indoor unit is specially designed to prevent air being blown against the ceiling to prevent ceiling stains
		Vertical auto swing	Possibility to select automatic vertical moving of the air discharge louvre, for uniform air flow and temperature distribution
		Fan speed steps	Multiple fan speeds to select, to optimize comfort levels
		Individual flap control	Individual flap control via the wired remote controller makes it simple to fix the position of each flap individually, to suit any new room configuration. Optional closure kits are available as well
Remote control & timer		Weekly timer	Timer can be set to start and stop operation anytime on a daily or weekly basis
		Infrared remote control	Infrared remote control with LCD to remotely control your indoor unit
		Wired remote control	Wired remote control to remotely control your indoor unit
		Centralised control	Centralised control to control several indoor units from one single point
Other functions		Auto-restart	The unit restarts automatically at the original settings after power failure
		Self-diagnosis	Simplifies maintenance by indicating system faults or operating anomalies
		Drain pump kit	Facilitates condensation draining from the indoor unit
		Multi tenant	The indoor unit's main power supply can be turned off when leaving the building or for servicing purposes

Ceiling mounted cassette units				Concealed ceiling units						Wall mounted unit	Ceiling suspended units		Floor standing units	
FXFQ-A	FXZQ-A	FXCQ-A	FXKQ-MA	FXDQ-M9	FXDQ-A	FXSQ-A	FXMQ-P7	FXMQ-MA9	FXTQ-A	FXAQ-P	FXHQ-A	FXUQ-A	FXNQ-A	FXLQ-P
•	•	•	•	•	•	•	•	•	•	•	•	•	•	•
•	•	•	•	•	•	•	•	•	•	•	•	•	•	•
•	•	•	•	•	•	•	•	•	•	•	•	•	•	•
•														
•	•													
•	•	•	•											
•	•	•	•	•	•	•	•	•	•	•	•	•	•	•
G1 F8 (optional)	G1	•	G1	•	•	G1 F8 (optional)	•	G1 F8 (optional)	•	•	G1	G1	G1	G1
•	•	•	•	•	•	•	•	•	•	•	•	•	•	•
•	•	•	•											
•	•	•	•							•		•		
3	3	3	2	2	3	3	3	2	3 (50~63) 2 (80~100)	2	3	3	2	2
•	•											•		
•	•	•	•	•	•	•	•	•	•	•	•	•	•	•
•	•	•	•	•	•	•	•	•	•	•	•	•	•	•
•	•	•	•	•	•	•	•	•	•	•	•	•	•	•
•	•	•	•	•	•	•	•	•	•	•	•	•	•	•
•	•	•	•	•	•	•	•	•	•	•	•	•	•	•
Standard	Standard	Standard	Standard		Standard	Standard	Standard	Optional	Standard (50-63) Optional (80-100)	Optional	Optional	Standard		
•	•	(•)	(•)	•	•	•	•	(•)	•	•	(•)	(•)	•	•

*Note: blue cells contain preliminary data

FXFQ-A



Check on
You Tube

<https://www.youtube.com/DaikinEurope>



Round flow cassette

Why choose a round flow cassette?

- 360° air discharge for optimum efficiency and comfort in shops, offices and restaurants.
- Unique auto-cleaning panel.

Unique functions which help save costs

› Daikin was the first company to launch a cassette using the round flow principle with sensors* and a unique auto-cleaning panel*.

... More energy efficient than any other

› The auto-cleaning panel* means:

- Running costs are reduced by 50% compared with standard solutions thanks to automatic daily filter cleaning.
- Less time is required to clean the filter: dust can be removed easily with a vacuum cleaner without opening the unit.



› Thanks to presence sensor, the unit changes its setpoint or switches off completely, if there are no people in the room, resulting in energy savings of up to 27%.

... And improved comfort

- › 360° air flow discharge pattern.
- › The presence sensor* directs the air away from anyone it detects in the room.
- › The floor sensor* detects the average floor temperature and ensures an even temperature distribution between the ceiling and the floor. Cold feet are history!

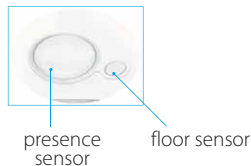

Flexible installation

› Flaps can be individually controlled or closed using the wired remote control, to suit room configuration. Optional closure kits are also available.

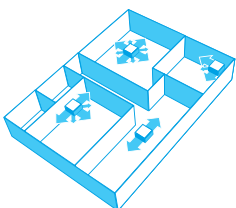

* available as an option

References

Wolverhampton, UK

Running costs were reduced by up to 50% compared with standard solutions thanks to daily filter cleaning.

Energy consumption (kWh)

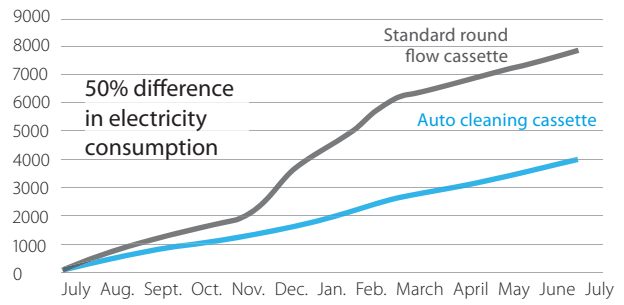

Cumulative energy comparison over 12 months

Benefits for the installer

- › Unique functions and design enhancing comfort, efficiency and installation.
- › Less time needed for onsite maintenance.
- › Use the controller to individually open or close any of the four flaps to easily adapt to a changing room layout.
- › Easy set-up of the sensor option to improve comfort and save energy.
- › Switch box and piping connections are accessible by just removing the panel, making servicing easier.

Benefits for the consultant

- › Product with unique functions in this market.
- › Designed for use in all types and sizes of commercial offices and retail environments.
- › Ideal product for improving BREEAM score/EPDB.

Benefits for the end user

- › Designed for use in all types and sizes of commercial offices and retail environments.
- › Perfect environment conditions: no more draughts or cold feet.
- › Save up to 50% on running costs with the auto-cleaning panel, which also facilitates maintenance.
- › Your customers can save up to 27% on their energy bills thanks to the sensor option.
- › Flexible use of space thanks to individual flap control.



Round flow cassette

360° air discharge for optimum efficiency and comfort

- › Daily automatic filter cleaning results in higher efficiency & comfort and lower maintenance costs
- › Two optional intelligent sensors improve energy efficiency and comfort
- › Individual flap control. Flexibility to suit every room layout without changing the location of the unit!
- › Lowest installation height in the market: 214mm for class 20-63
- › Modern style decoration panel is available in 3 different variations: white (RAL9010) with grey louvers, full white (RAL9010) or auto cleaning panel
- › Reduced energy consumption thanks to specially developed small tube heat exchanger, DC fan motor and drain pump
- › Fresh air intake integrated in the same system thus reducing installation cost as no additional ventilation is required

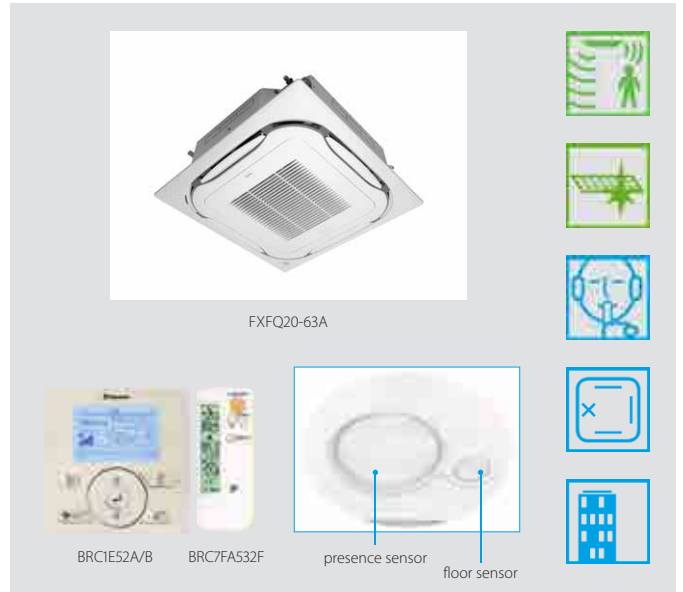

Fresh air intake opening in casing



* Brings in up to 10% of fresh air into the room

Optional fresh air intake kit

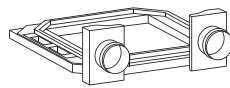

* Allows larger quantities of fresh air to be brought in
 * Distributes fresh air so it is most effectively pre-cooled / pre-heated

- › Branch duct discharge allows to optimize air distribution in irregular shaped rooms or to supply air to small adjacent rooms

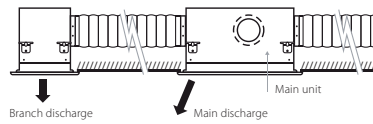

- › Standard drain pump with 850mm lift increases flexibility and installation speed

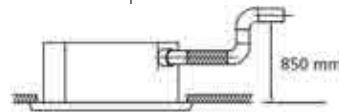

Indoor unit			FXFQ	20A	25A	32A	40A	50A	63A	80A	100A	125A						
Cooling capacity	Nom.		kW	2.2	2.8	3.6	4.5	5.6	7.1	9.0	11.2	14.0						
Heating capacity	Nom.		kW	2.5	3.2	4.0	5.0	6.3	8.0	10.0	12.5	16.0						
Power input - 50Hz	Cooling	Nom.	kW	0.038			0.053		0.061	0.092	0.115	0.186						
	Heating	Nom.	kW	0.038			0.053		0.061	0.092	0.115	0.186						
Dimensions	Unit	Height	mm	204						246		288						
		Width	mm	840														
		Depth	mm	840														
Weight	Unit		kg	19		20		21		24		26						
Casing	Material			Galvanised steel plate														
	Model			BYCQ140D7W1														
Decoration panel	Colour			Pure White (RAL 9010)														
	Dimensions	HeightxWidthxDepth	mm	60x950x950														
	Weight		kg	5.4														
	Model			BYCQ140D7W1W														
Decoration panel 2	Colour			Pure White (RAL 9010)														
	Dimensions	HeightxWidthxDepth	mm	60x950x950														
	Weight		kg	5.4														
	Model			BYCQ140D7GW1														
Decoration panel 3	Colour			Pure White (RAL 9010)														
	Dimensions	HeightxWidthxDepth	mm	145x950x950														
	Weight		kg	10.3														
Fan-Air flow rate - 50Hz	Cooling	High/Nom./Low	m³/min	12.5/10.6/8.8			13.6/11.6/9.5		15.0/12.8/10.5		16.5/13.5/10.5		22.8/17.6/12.4		26.5/19.5/12.4		33.0/26.5/19.9	
	Heating	High/Nom./Low	m³/min	12.5/10.6/8.8			13.6/11.6/9.5		15.0/12.8/10.5		16.5/13.5/10.5		22.8/17.6/12.4		26.5/19.5/12.4		33.0/26.5/19.9	
Air filter	Type			Resin net with mold resistance														
Sound power level	Cooling	High/Nom.	dB(A)	49/-			51/-		53/-		55/-		60/-		61/-			
	Heating	High/Nom./Low	dB(A)	31/29/28			33/31/29		35/33/30		38/34/30		43/37/30		45/41/36			
Sound pressure level	Cooling	High/Nom./Low	dB(A)	31/29/28			33/31/29		35/33/30		38/34/30		43/37/30		45/41/36			
	Heating	High/Nom./Low	dB(A)	31/29/28			33/31/29		35/33/30		38/34/30		43/37/30		45/41/36			
Refrigerant	Type / GWP			R-410A / 2.087,5														
Piping connections	Liquid	OD	mm	6.35						9.52								
	Gas	OD	mm	12.7						15.9								
	Drain			VP25 (O.D. 32 / I.D. 25)														
Power supply	Phase/Frequency/Voltage		Hz/V	1~/50/60/220-240/220														
Current - 50Hz	Maximum fuse amps (MFA)		A	16														
Control systems	Infrared remote control			BRC7FA532F														
	Simplified wired remote control for hotel applications			-														
	Wired remote control			BRC1D52 / BRC1E52A/B														

BYCQ140D7W1 = pure white panel with grey louvers, BYCQ140D7W1W = pure white standard panel with white louvers, BYCQ140D7GW1 = Pure white auto cleaning panel
 The BYCQ140D7W1W has white insulations. Be informed that formations of dirt on white insulation is visibly stronger & that it is consequently not advised to install the decoration panel in environments exposed to concentrations of dirt.

FXFQ20-63A WITH AUTO-CLEANING PANEL

300 or less 860-910 (Ceiling opening, see note 3)

710 (Suspension position)

See note 5

780 (Suspension position)
860-910 (Ceiling opening, see note 3)

2300 or more (Insulation space)

1 Liquid pipe connection
2 Gas pipe connection
3 Drain pipe connection
4 Power supply entry hole
5 Transmission wiring entry hole
6 Air discharge opening
7 Air suction grille
8 Corner decoration cover
9 Drain hose
10 Knock out hole

Model
FCQG35-71F, FXFQ20-63A

Notes:

- Location of the nameplates:
- Unit body: on the control box cover.
- Decoration panel: on the panel frame at the piping side under the corner cover.
- When installing an optional accessory, refer to the installation drawings.
- For fresh air intake kit an inspection part is necessary.
- Make sure the spacing between the ceiling and the cassette is no more than 35mm.
MAX ceiling opening: 310mm.
- When the conditions exceed 30°C and RH 80% in the ceiling or fresh air is inducted into the ceiling, an additional insulation is required (polyethylene foam, thickness 10 mm or more).
- In case of using a sensor kit, this position will be a sensor, refer to the drawing of the sensor kit for more detail.

Required space
In case a discharge opening is closed with the 'sealing member' option, the distance of 1500mm can be reduced to 500mm on the closed side.

FXFQ80-125A WITH AUTO-CLEANING PANEL

300 or less 860-910 (Ceiling opening, see note 3)

710 (Suspension position)

See note 5

780 (Suspension position)
860-910 (Ceiling opening, see note 3)

2500 or more (Insulation space)

1 Liquid pipe connection
2 Gas pipe connection
3 Drain pipe connection
4 Power supply entry hole
5 Transmission wiring entry hole
6 Air discharge opening
7 Air suction grille
8 Corner decoration cover
9 Drain hose
10 Knock out hole

AA	Model
246	FCQG100-140F, FXFQ80-100A
288	FCQG71-140F, FXFQ125A

Notes:

- Location of the nameplates:
- Unit body: on the control box cover.
- Decoration panel: on the panel frame at the piping side under the corner cover.
- When installing an optional accessory, refer to the installation drawings.
- For fresh air intake kit an inspection part is necessary.
- Make sure the spacing between the ceiling and the cassette is no more than 35mm.
MAX ceiling opening: 310mm.
- When the conditions exceed 30°C and RH 80% in the ceiling or fresh air is inducted into the ceiling, an additional insulation is required (polyethylene foam, thickness 10 mm or more).
- In case of using a sensor kit, this position will be a sensor, refer to the drawing of the sensor kit for more detail.

Required space
In case a discharge opening is closed with the 'sealing member' option, the distance of 1500mm can be reduced to 500mm on the closed side.

FXFQ20-63A WITH STANDARD PANEL

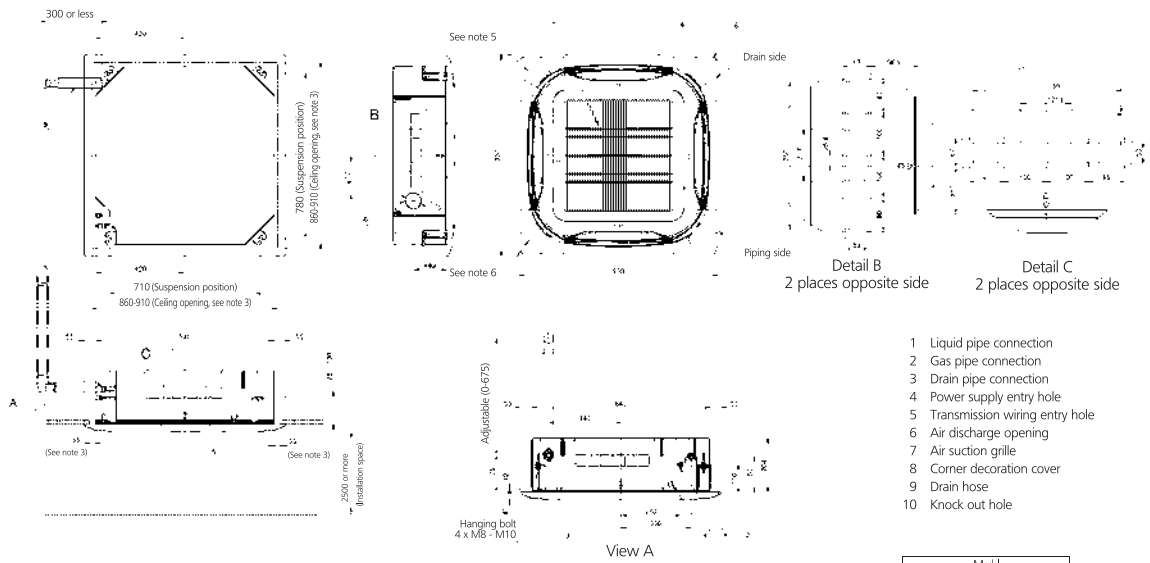

Notes:

1. Location of the nameplates:
- Unit body: on the control box cover.
- Decoration panel: on the panel frame at the piping side under the corner cover.
2. When installing an optional accessory, refer to the installation drawings.
- For fresh air intake kit an inspection part is necessary.
3. Make sure the spacing between the ceiling and the cassette is no more than 35mm.
MAX ceiling opening: 310mm.
4. When the conditions exceed 30°C and RH 80% in the ceiling or fresh air is inducted into the ceiling, an additional insulation is required (polyethylene foam, thickness 10 mm or more).
5. In case of using a sensor kit, this position will be a sensor, refer to the drawing of the sensor kit for more detail.
6. In case of using an infrared controller, this position will be a receiver, refer to the drawing of the infrared controller for more detail.

Please respect the distances as shown on figure.

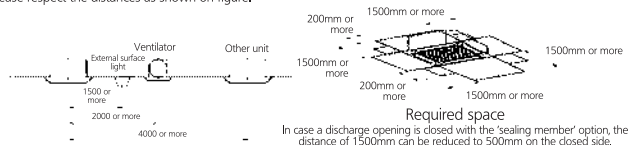

Indoor Units

FXFQ80-125A WITH STANDARD PANEL

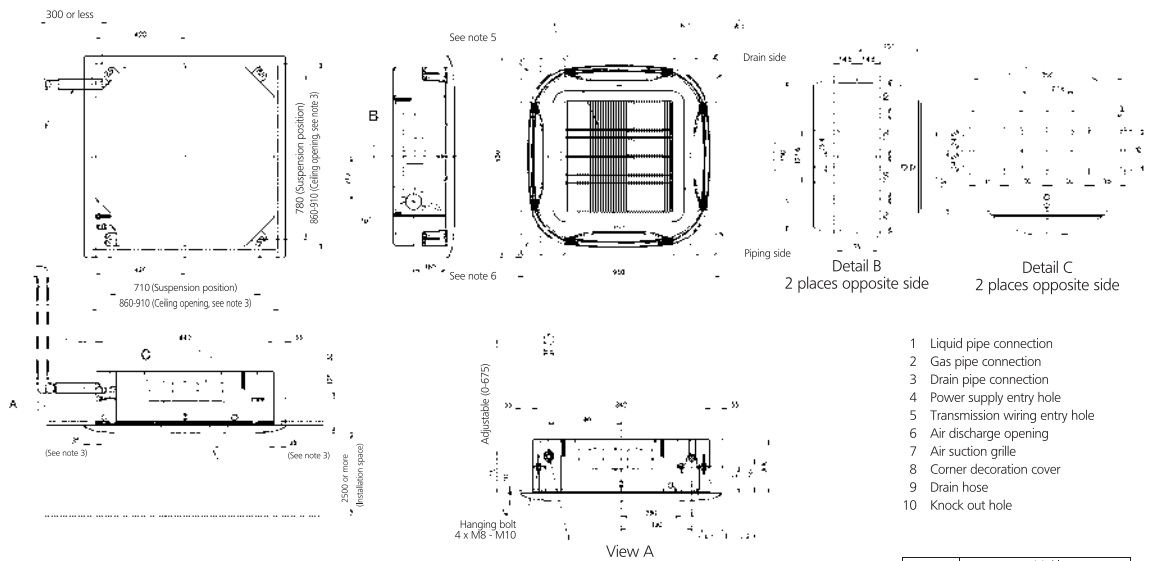

Notes:

1. Location of the nameplates:
- Unit body: on the control box cover.
- Decoration panel: on the panel frame at the piping side under the corner cover.
2. When installing an optional accessory, refer to the installation drawings.
- For fresh air intake kit an inspection part is necessary.
3. Make sure the spacing between the ceiling and the cassette is no more than 35mm.
MAX ceiling opening: 310mm.
4. When the conditions exceed 30°C and RH 80% in the ceiling or fresh air is inducted into the ceiling, an additional insulation is required (polyethylene foam, thickness 10 mm or more).
5. In case of using a sensor kit, this position will be a sensor, refer to the drawing of the sensor kit for more detail.
6. In case of using an infrared controller, this position will be a receiver, refer to the drawing of the infrared controller for more detail.

Please respect the distances as shown on figure.

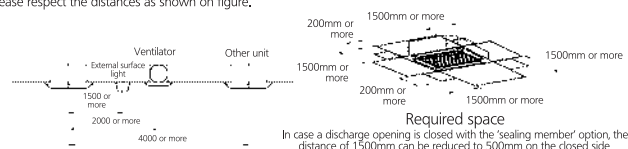

3D077130D

FXZQ-A



Check on
You Tube

<https://www.youtube.com/DaikinEurope>



Fully Flat Cassette

Design & Genius in one

- Unique design in the market that integrates fully flat into the ceiling

Benefits for the installer

- › Unique product in the market!
- › The user-friendly remote control, available in several languages, enables the easy set-up of sensor option and control of the individual flap position
- › Meeting European design taste.

Benefits for the consultant

- › Unique product in the market!
- › Blends seamlessly in any modern office interior design
- › Flexible usage of space thanks to individual flap control
- › Ideal product to improve BREEAM score/EPDB

Benefits for the end user

- › Engineering excellence and unique design in one
- › Most silent unit
- › Perfect working conditions: no more cold draughts or cold feet
- › Save up to 27% on your energy bill thanks to the optional sensors
- › Flexible usage of space thanks to individual flap control
- › User-friendly remote control, available in several languages.

Unique design

- › Designed by German design office to fully meet the European taste.
- › Integrated Fully Flat into the ceiling.
- › Fully integrated in the one ceiling tile, enabling lights, speakers and sprinklers to be installed in adjoining ceiling tiles.
- › Decoration panel available in 2 colours (white and white-silver).

Comfort through unique technology

Most silent cassette in the market (25dBA)

Presence sensor (optional)

- › When the room is empty, it can adjust the set temperature or switch off the unit – saving energy.
- › When people are detected, the direction of the airflow is adapted to avoid cold draughts being directed towards occupants.

Floor sensor (optional)

- › Detects the temperature difference and re-directs the airflow to ensure even temperature distribution.

Top efficiency

- › When the room is empty, the sensor option can adjust the set temperature or switch off the unit – saving up to 27% energy.
- › Individual flap control: easily control one or more flaps via the wired remote controller (BRC1E52) when rearranging the room. When fully closing or blocking the flaps, the option “Sealing member of air discharge outlet” is needed.



Fully flat cassette

Unique design in the market that integrates fully flat into the ceiling

- › Remarkable blend of iconic design and engineering excellence
- › Two optional intelligent sensors improve energy efficiency and comfort
- › 15 class unit especially developed for small or well-insulated rooms, such as small offices.
- › Individual flap control. Flexibility to suit every room layout without changing the location of the unit!

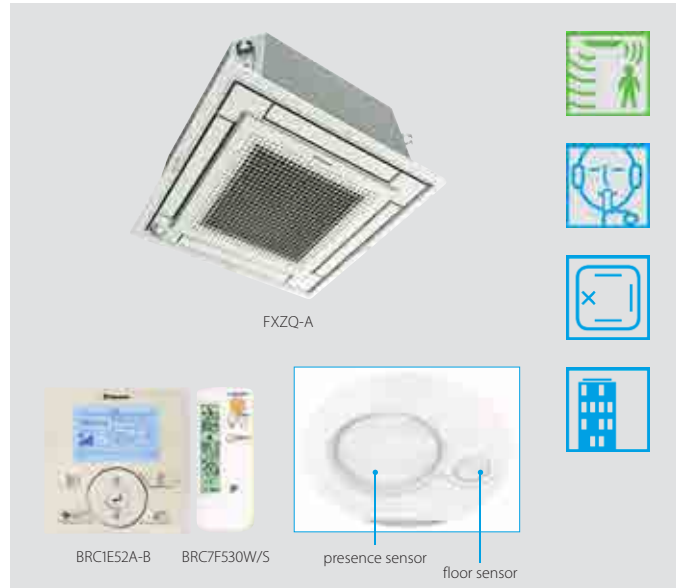
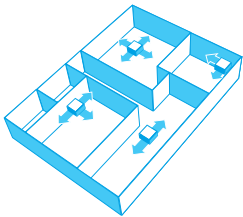

- › Reduced energy consumption thanks to specially developed small tube heat exchanger, DC fan motor and drain pump
- › Fresh air intake integrated in the same system thus reducing installation cost as no additional ventilation is required

Fresh air intake opening in casing

Optional fresh air intake kit

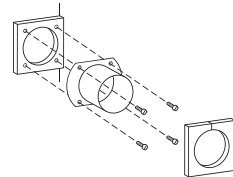

* Brings in up to 10% of fresh air into the room

* Allows larger quantities of fresh air to be brought in

- › Branch duct discharge allows to optimize air distribution in irregular shaped rooms or to supply air to small adjacent rooms

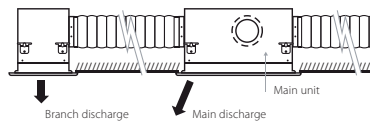

- › Standard drain pump with 850mm lift increases flexibility and installation speed

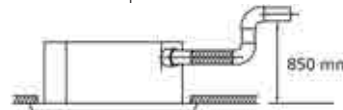

Indoor unit			FXZQ	15A	20A	25A	32A	40A	50A
Cooling capacity	Nom.		kW	1.7	2.2	2.8	3.6	4.5	5.6
Heating capacity	Nom.		kW	1.9	2.5	3.2	4.0	5.0	6.3
Power input - 50Hz	Cooling	Nom.	kW	0.043			0.045	0.059	0.092
	Heating	Nom.	kW	0.036			0.038	0.053	0.086
Dimensions	Unit	Height	mm	260					
		Width	mm	575					
		Depth	mm	575					
Weight	Unit		kg	15.5		16.5		18.5	
Casing	Material			Galvanised steel plate					
Decoration panel	Model			BYFQ60CW					
	Colour			White (N9.5)					
	Dimensions	HeightxWidthxDepth	mm	46x620x620					
	Weight		kg	2.8					
Decoration panel 2	Model			BYFQ60CS					
	Colour			White (N9.5) + Silver					
	Dimensions	HeightxWidthxDepth	mm	46x620x620					
	Weight		kg	2.8					
Decoration panel 3	Model			BYFQ60B3W1					
	Colour			White (RAL9010)					
	Dimensions	HeightxWidthxDepth	mm	55x700x700					
	Weight		kg	2.7					
Fan-Air flow rate - 50Hz	Cooling	High/Nom./Low	m ³ /min	8.5/7/6.5	8.7/7.5/6.5	9/8/6.5	10/8.5/7	11.5/9.5/8	14.5/12.5/10
	Heating	High/Nom./Low	m ³ /min	8.5/7/6.5	8.7/7.5/6.5	9/8/6.5	10/8.5/7	11.5/9.5/8	14.5/12.5/10
Air filter	Type			Resin net with mold resistance					
Sound power level	Cooling	High/Nom.	dBA	49/-		50/-	51/-	54/-	60/-
	Heating	High/Nom./Low	dBA	31.5/28/25.5	32/29.5/25.5	33/30/25.5	33.5/30/26	37/32/28	43/40/33
Sound pressure level	Cooling	High/Nom./Low	dBA	31.5/28/25.5	32/29.5/25.5	33/30/25.5	33.5/30/26	37/32/28	43/40/33
	Heating	High/Nom./Low	dBA	31.5/28/25.5	32/29.5/25.5	33/30/25.5	33.5/30/26	37/32/28	43/40/33
Refrigerant	Type / GWP			R-410A / 2.087,5					
Piping connections	Liquid	OD	mm	6.35					
	Gas	OD	mm	12.7					
	Drain			VP20 (I.D. 20/O.D. 26)					
Power supply	Phase/Frequency/Voltage		Hz/V	1~/50/220-240					
Current - 50Hz	Maximum fuse amps (MFA)		A	16					
Control systems	Infrared remote control			BRC7F530W (white panel) / BRC7EB530 (standard panel) / BRC7F530S (grey panel)					
	Simplified wired remote control for hotel applications			-					
	Wired remote control			BRC1D52 / BRC1E52A/B					

Dimensions include control box

FXZQ-A NEW PANEL

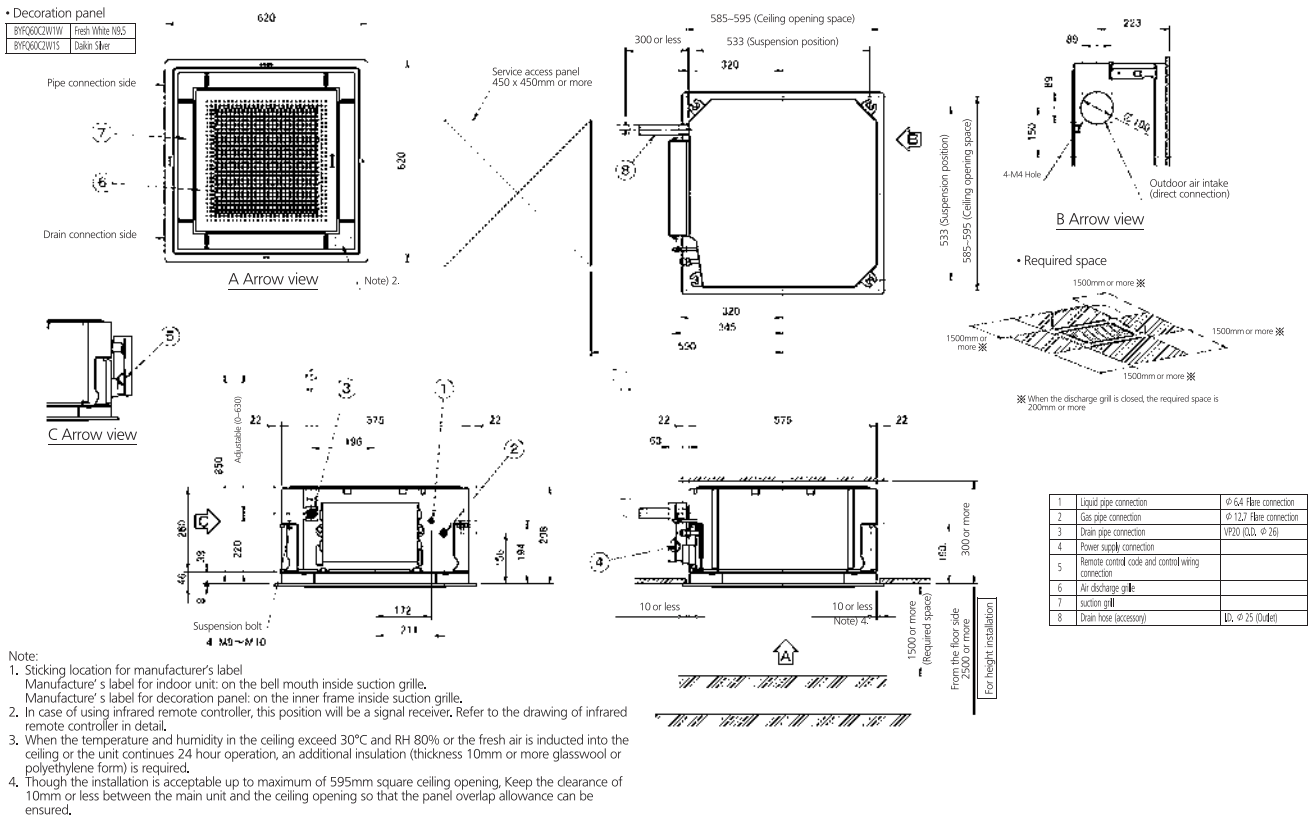

FXZQ-A OLD PANEL

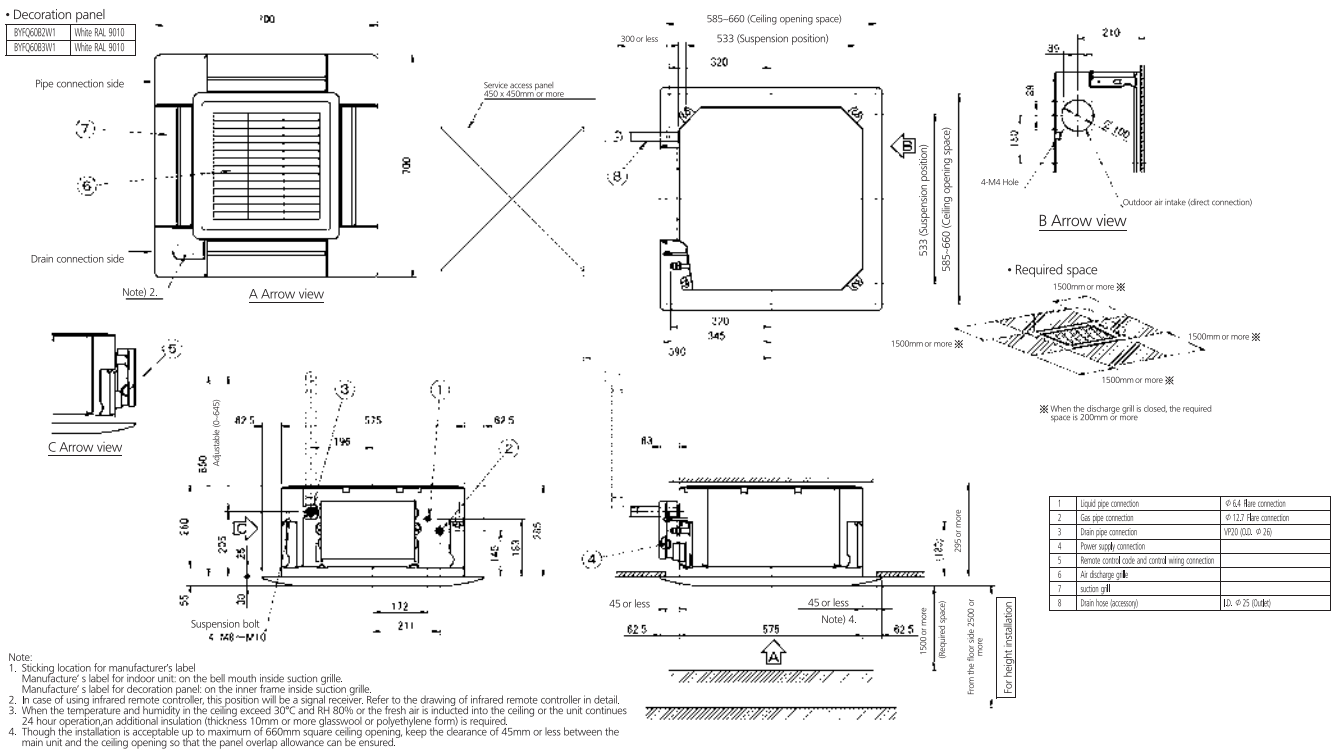

2-way blow ceiling mounted cassette

Thin, lightweight design installs easily in narrow corridors

- › Depth of all units is 620mm, ideal for narrow corridors
- › Refurbishing the room ? With individual flap control, one or more flaps can be easily closed via the wired remote control
- › Reduced energy consumption thanks to specially developed small tube heat exchanger, DC fan motor and drain pump
- › Fresh air intake integrated in the same systems thus reducing installation cost as no additional ventilation is required

Fresh air intake opening in casing



* Brings in up to 10% of fresh air into the room

- › Stylish unit blends easily with any interior. The flaps close entirely when the unit is not operating and there are no air intake grilles visible
- › Optimum comfort guaranteed with automatic air flow adjustment to the required load
- › Maintenance operations can be performed by removing the front panel
- › Branch duct discharge allows to optimize air distribution in irregular shaped rooms or to supply air to small adjacent rooms

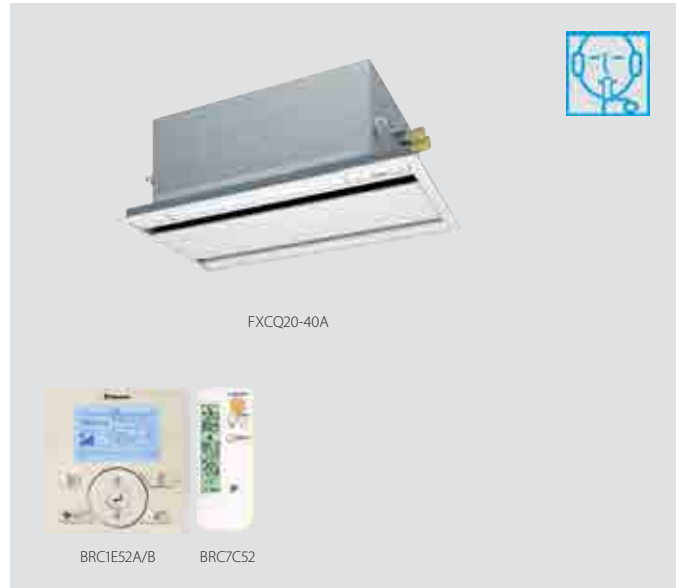
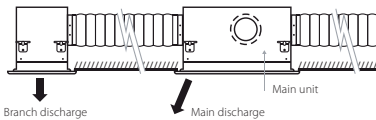

- › Standard drain pump with 500mm lift increases flexibility and installation speed

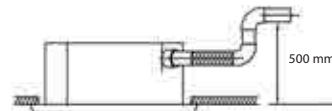

Indoor unit			FXCQ	20A	25A	32A	40A	50A	63A	80A	125A	
Cooling capacity	Nom.		kW	2.2	2.8	3.6	4.5	5.6	7.1	9.0	14.0	
Heating capacity	Nom.		kW	2.5	3.2	4.0	5.0	6.3	8.0	10.0	16.0	
Power input - 50Hz	Cooling	Nom.	kW	0.031	0.039		0.041	0.059	0.063	0.090	0.149	
	Heating	Nom.	kW	0.028	0.035		0.037	0.056	0.060	0.086	0.146	
Dimensions	Unit	Height	mm	305								
		Width	mm	775				990		1,445		
		Depth	mm	620								
		Weight	kg	19				22	25	33	38	
Casing	Material		Galvanised steel plate									
Decoration panel	Model		BYBCQ40HW1			BYBCQ63HW1			BYBCQ125HW1			
	Colour		Fresh white (6.5Y 9.5/0.5)									
	Dimensions	HeightxWidthxDepth	mm	55x1,070x700				55x1,285x700		55x1,740x700		
	Weight		kg	10			11		13			
Fan-Air flow rate - 50Hz	Cooling	High/Nom./Low	m ³ /min	10.5/9/7.5	11.5/9.5/8		12/10.5/8.5	15/13/10.5	16/14/11.5	26/22.5/18.5	32/27.5/22.5	
Air filter	Type		Resin net with mold resistance									
Sound power level	Cooling	Nom.	dB(A)	-								
Sound pressure level	Cooling	High/Nom./Low	dB(A)	32.0/30.0/28.0	34.0/31.0/29.0	34.0/32.0/30.0	36.0/33.0/31.0	37.0/35.0/31.0	39.0/37.0/32.0	42.0/38.0/33.0	46.0/42.0/38.0	
	Heating	High/Nom./Low	dB(A)	32.0/30.0/28.0	34.0/31.0/29.0	34.0/32.0/30.0	36.0/33.0/31.0	37.0/35.0/31.0	39.0/37.0/32.0	42.0/38.0/33.0	46.0/42.0/38.0	
Refrigerant	Type / GWP		R-410A / 2,087,5									
Piping connections	Liquid	OD	mm	6.35				9.52				
	Gas	OD	mm	12.7				15.9				
	Drain			VP25 (O.D. 32 / I.D. 25)								
Power supply	Phase/Frequency/Voltage		Hz/V	1~/50/220-240								
Current - 50Hz	Maximum fuse amps (MFA)		A	16								
Control systems	Infrared remote control			BRC7C52								
	Simplified wired remote control for hotel applications			-								
	Wired remote control			BRC1D52 / BRC1E52A/B								

FXCQ20-40A

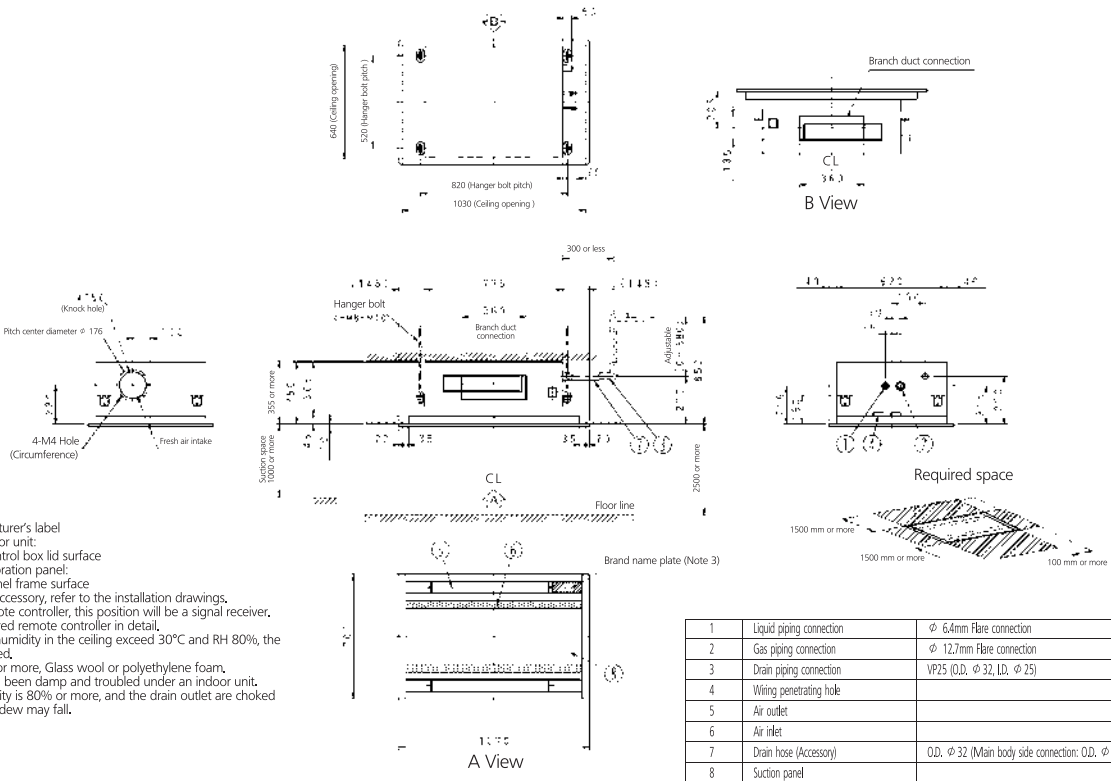

FXCQ50A

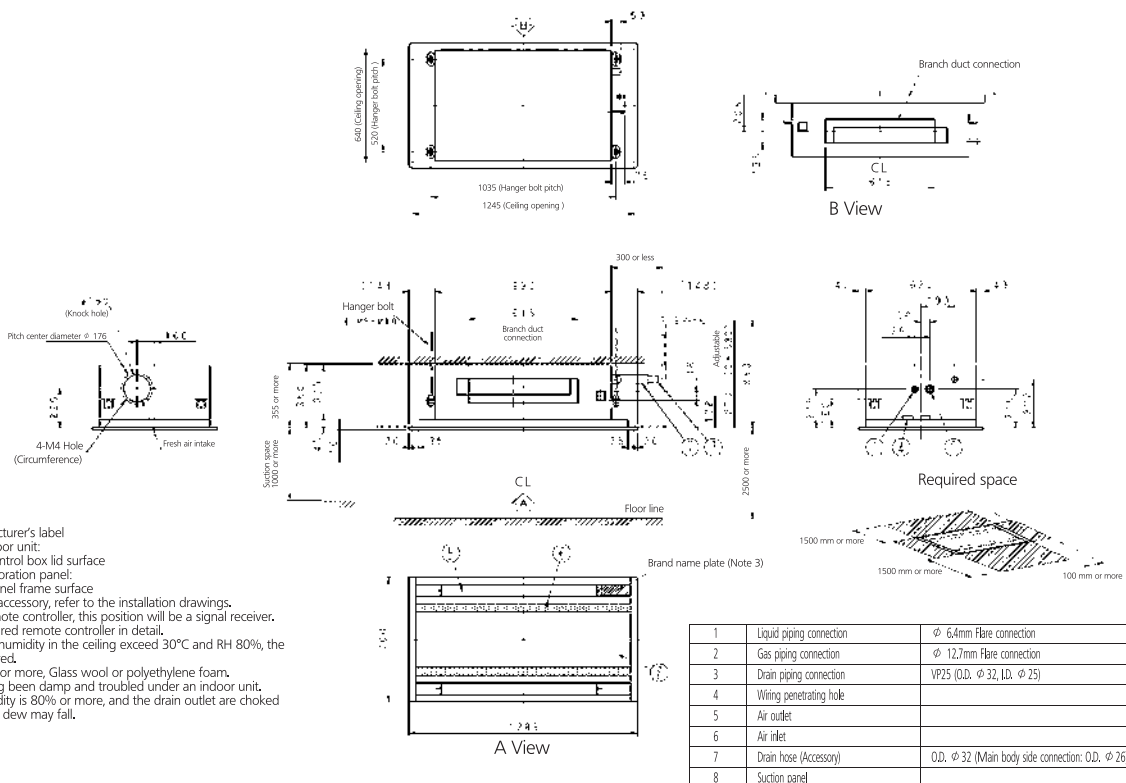

FXCQ63A

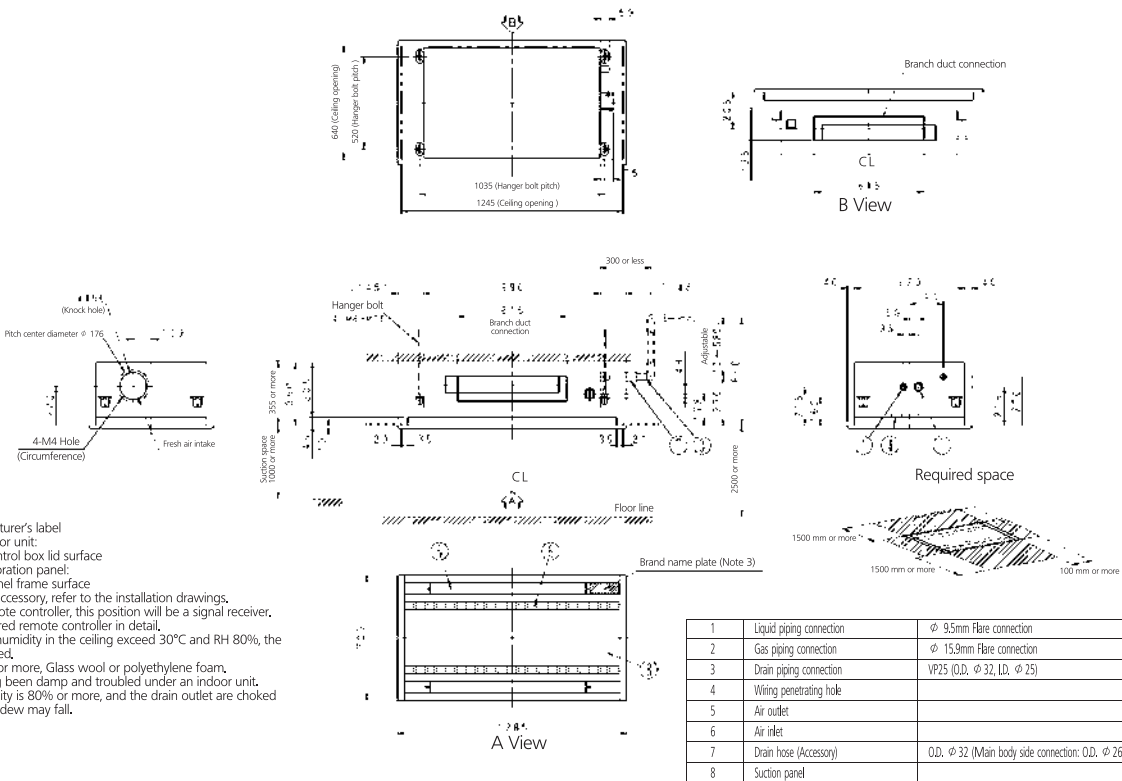

FXCQ80-125A

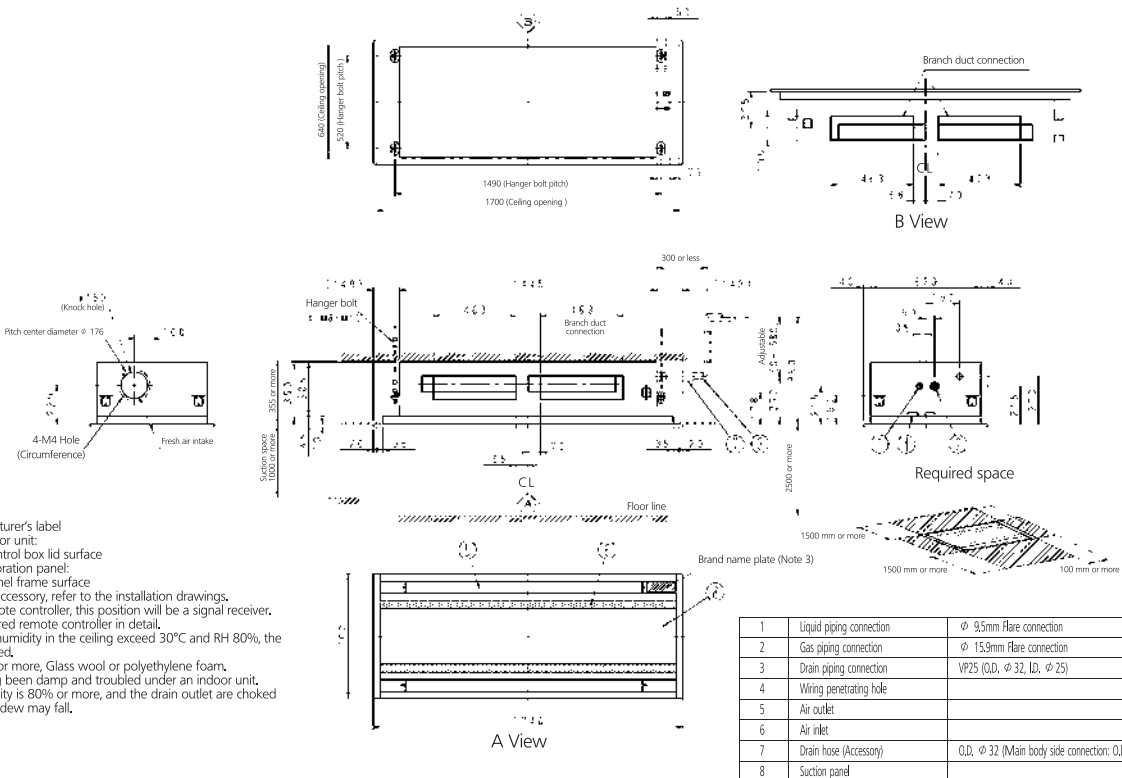

Ceiling mounted corner cassette

1-way blow unit for corner installation

- › Compact dimensions, can easily be mounted in a narrow ceiling void (only 220mm ceiling space required, 195 with panel spacer, available as accessory)
- › Optimum air flow conditions are created by either downward air discharge or frontal air discharge (via optional grille) or a combination of both

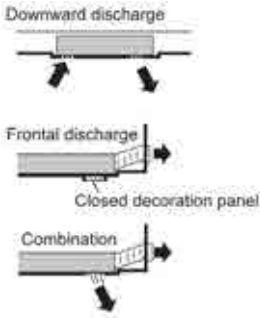

- › Maintenance operations can be performed by removing the front panel
- › Standard drain pump with 500mm lift increases flexibility and installation speed

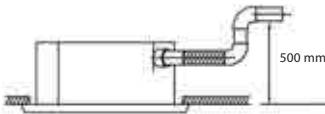

Indoor unit			FXKQ	25MA	32MA	40MA	63MA
Cooling capacity	Nom.		kW	2.8	3.6	4.5	7.10
Heating capacity	Nom.		kW	3.2	4.0	5.0	8.00
Power input - 50Hz	Cooling	Nom.	kW	0.066		0.076	0.105
	Heating	Nom.	kW	0.046		0.056	0.085
Dimensions	Unit	Height	mm	215			
		Width	mm	1,110			1,310
		Depth	mm	710			
Weight	Unit		kg	31			34
Casing	Material			Galvanised steel plate			
Decoration panel	Model			BYK45FJW1			BYK71FJW1
	Colour			White			
	Dimensions	HeightxWidthxDepth	mm	70x1,240x800			70x1,440x800
	Weight		kg	8.5			9.5
Fan-Air flow rate - 50Hz	Cooling	High/Low	m ³ /min	11/9		13/10	18/15
Air filter	Type			Resin net with mold resistance			
Sound power level	Cooling	Nom.	dBA	-			
Sound pressure level	Cooling	High/Low	dBA	38.0/33.0		40.0/34.0	42.0/37.0
Refrigerant	Type / GWP			R-410A / 2.087,5			
Piping connections	Liquid	OD	mm	6.35			9.52
	Gas	OD	mm	12.7			15.9
	Drain			VP25 (O.D. 32 / I.D. 25)			
Power supply	Phase/Frequency/Voltage		Hz/V	1~/50/60/220-240/220			
Current - 50Hz	Maximum fuse amps (MFA)		A	15			
Control systems	Infrared remote control			BRC4C61			
	Simplified wired remote control for hotel applications			-			
	Wired remote control			BRC1D52 / BRC1E52A/B			

FXKQ25, 32, 40MA

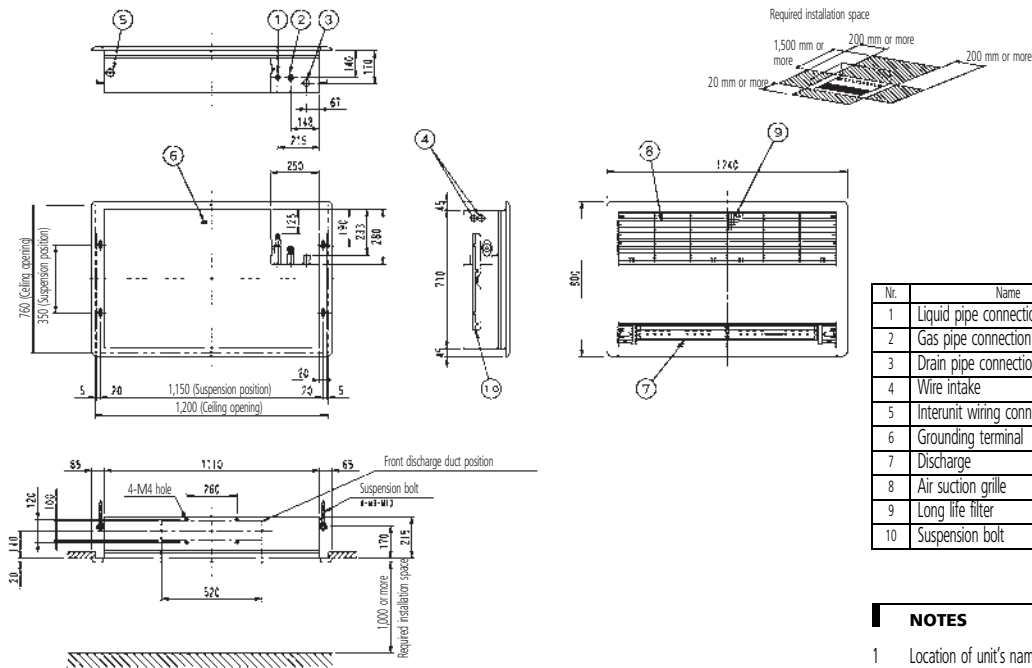

Nr.	Name	Description
1	Liquid pipe connection	ø 6.4 Flare connection
2	Gas pipe connection	ø 12.7 Flare connection
3	Drain pipe connection	VP25 (O.D. ø 32)
4	Wire intake	
5	Interunit wiring connection	
6	Grounding terminal	Inside switch box (M4)
7	Discharge	
8	Air suction grille	
9	Long life filter	
10	Suspension bolt	

NOTES

- Location of unit's name plate:
 - For main body: Bottom part of fan housing inside of air suction grille.
 - For decoration panel: Service lid face inside of air suction grille.
- When installing an optional accessory, refer to the installation drawings.

FXKQ63MA

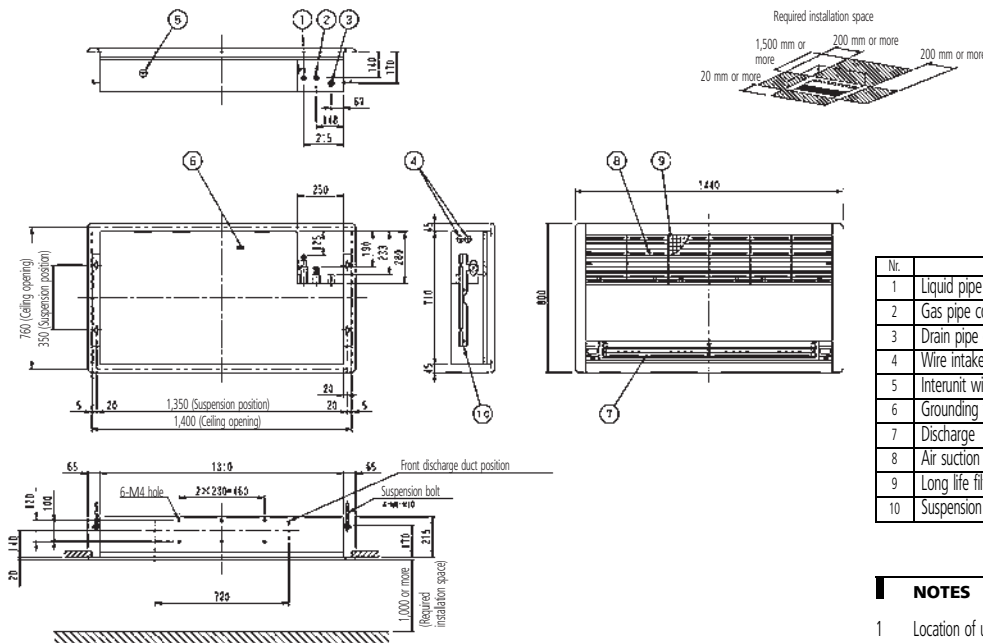

Nr.	Name	Description
1	Liquid pipe connection	ø 9.5 Flare connection
2	Gas pipe connection	ø 15.9 Flare connection
3	Drain pipe connection	VP25 (O.D. ø 32)
4	Wire intake	
5	Interunit wiring connection	
6	Grounding terminal	Inside switch box (M4)
7	Discharge	
8	Air suction grille	
9	Long life filter	
10	Suspension bolt	

NOTES

- Location of unit's name plate:
 - For main body: Bottom part of fan housing inside of air suction grille.
 - For decoration panel: Service lid face inside of air suction grille.
- When installing an optional accessory, refer to the installation drawings.

Small concealed ceiling unit

Designed for hotel applications

- › Compact unit (230mm high & 652mm deep), can easily be mounted in narrow ceiling voids
- › Discretely concealed in the ceiling: only the suction and discharge grilles are visible
- › Flexible installation, as the air suction direction can be altered from rear to bottom suction

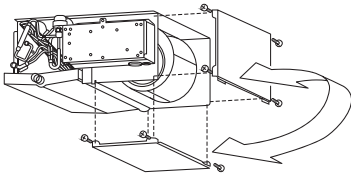

- › For easy mounting, the drain pan can be located to the left or right of the unit

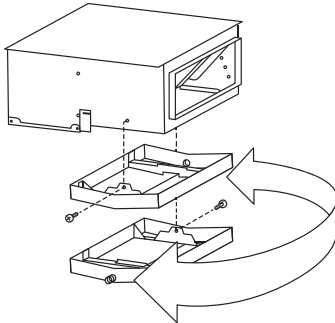

Indoor unit			FXDQ	20M9	25M9
Cooling capacity	Nom.		kW	2.2	2.8
Heating capacity	Nom.		kW	2.5	3.2
Power input - 50Hz	Cooling	Nom.	kW		0.050
	Heating	Nom.	kW		0.050
Dimensions	Unit	Height	mm		230
		Width	mm		502
		Depth	mm		652
Required ceiling void >			mm		250
Weight	Unit		kg		17
Casing	Colour			Unpainted	
	Material			Galvanised steel	
Fan-Air flow rate - 50Hz	Cooling	High/Low	m ³ /min	6.7/5.2	7.4/5.8
	Heating	High/Low	m ³ /min	6.7/5.2	7.4/5.8
Air filter	Type			Resin net with mold resistance	
Sound power level	Cooling	Nom.	dBA	50	
Sound pressure level	Cooling	High/Low	dBA	37/32	
	Heating	High/Low	dBA	37/32	
Refrigerant	Type / GWP			R-410A / 2.087,5	
Piping connections	Liquid	OD	mm	6.35	
	Gas	OD	mm	12.7	
	Drain			I.D. 21.6, O.D. 27.2	
Power supply	Phase/Frequency/Voltage		Hz/V	1~/50/230	
Current - 50Hz	Maximum fuse amps (MFA)		A	16	
Control systems	Infrared remote control			BRC4C62	
	Simplified wired remote control for hotel applications			BRC2E52C (heat recovery type) / BRC3E52C (heat pump type)	
	Wired remote control			BRC1D52 / BRC1E52A/B	

FXDQ-M9

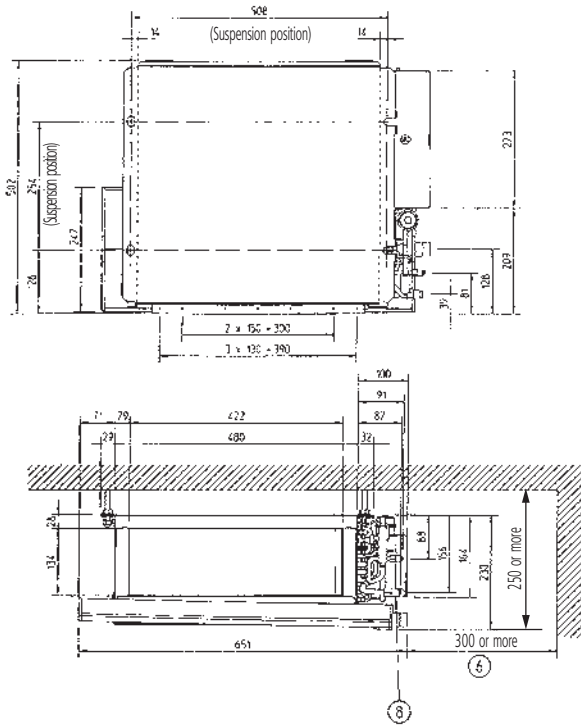

Nr	Part name
1	Liquid pipe connection (ø 6.35)
2	Gas pipe connection (ø 12.7)
3	Drain hole (o.d. ø 27.2 - i.d. ø 21.6)
4	Transmission wiring port
5	Power supply wiring port
6	Service space
7	Switch box
8	Nameplate

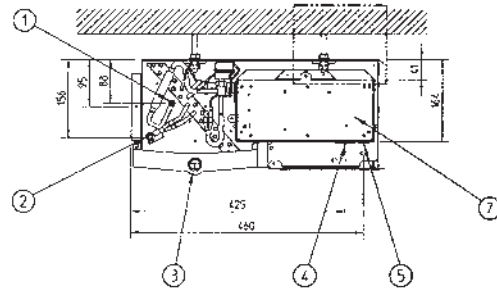

Slim concealed ceiling unit

Slim design for flexible installation

- › Compact dimensions, can easily be mounted in a ceiling void of only 240mm



- › Medium external static pressure up to 44Pa facilitates unit use with flexible ducts of varying lengths
- › Discretely concealed in the ceiling: only the suction and discharge grilles are visible
- › 15 class unit especially developed for small or well-insulated rooms, such as hotel bedrooms, small offices, etc.
- › Reduced energy consumption thanks to specially developed DC fan motor
- › Flexible installation, as the air suction direction can be altered from rear to bottom suction

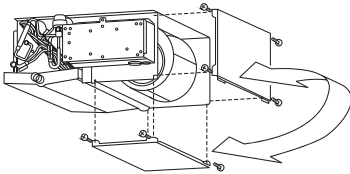

- › Standard drain pump with 750mm lift increases flexibility and installation speed

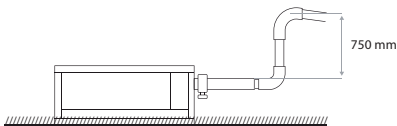

Indoor unit			FXDQ	15A	20A	25A	32A	40A	50A	63A
Cooling capacity	Nom.		kW	1.7	2.2	2.8	3.6	4.5	5.6	7.1
Heating capacity	Nom.		kW	1.9	2.5	3.2	4.0	5.0	6.3	8.0
Power input - 50Hz	Cooling	Nom.	kW	0.071			0.078		0.099	0.110
	Heating	Nom.	kW	0.068			0.075		0.096	0.107
Dimensions	Unit	Height	mm				200			
		Width	mm	750			950		1,150	
		Depth	mm				620			
Required ceiling void >			mm				240			
Weight	Unit		kg	22			26		29	
Casing	Colour			Galvanised steel / Non painted						
Fan-Air flow rate - 50Hz	Cooling	High/Nom./Low	m ³ /min	7.5/7.0/6.4	8.0/7.2/6.4			10.5/9.5/8.5	12.5/11.0/10.0	16.5/14.5/13.0
Fan-External static pressure - 50Hz	High/Nom.		Pa	30/10			44/15			
Air filter	Type			Removable / washable / mildew proof						
Sound power level	Cooling	Nom.	dBA	50	51			52	53	54
	Cooling	High/Nom./Low	dBA	32/31/27	33/31/27			34/32/28	35/33/29	36/34/30
Refrigerant	Type / GWP			R-410A / 2.087,5						
Piping connections	Liquid	OD	mm				9.52			
	Gas	OD	mm				12.7		15.9	
	Drain			VP20 (I.D. 20/O.D. 26)						
Power supply	Phase/Frequency/Voltage		Hz/V	1~/50/60/220-240/220						
Current - 50Hz	Maximum fuse amps (MFA)		A	16						
Control systems	Infrared remote control			BRC4C65						
	Simplified wired remote control for hotel applications			BRC2E52C (heat recovery type) / BRC3E52C (heat pump type)						
	Wired remote control			BRC1D52 / BRC1E52A/B						

FXDQ15-32A

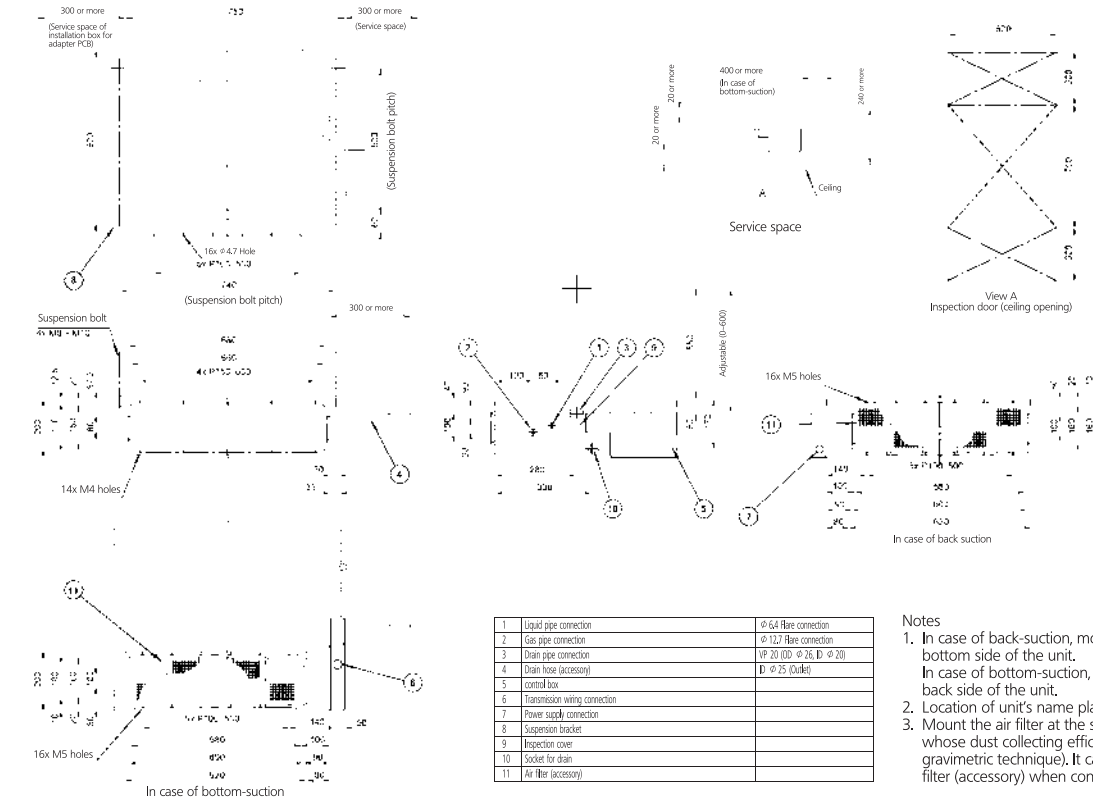

- Notes**
- In case of back-suction, mount chamber cover to bottom side of the unit.
In case of bottom-suction, mount chamber cover to back side of the unit.
 - Location of unit's name plate: control box cover.
 - Mount the air filter at the suction side. (Use an air filter whose dust collecting efficiency is at least 50% in a gravimetric technique). It can not be equipped with air filter (accessory) when connecting duct to suction side.

Indoor Units

FXDQ40-50A

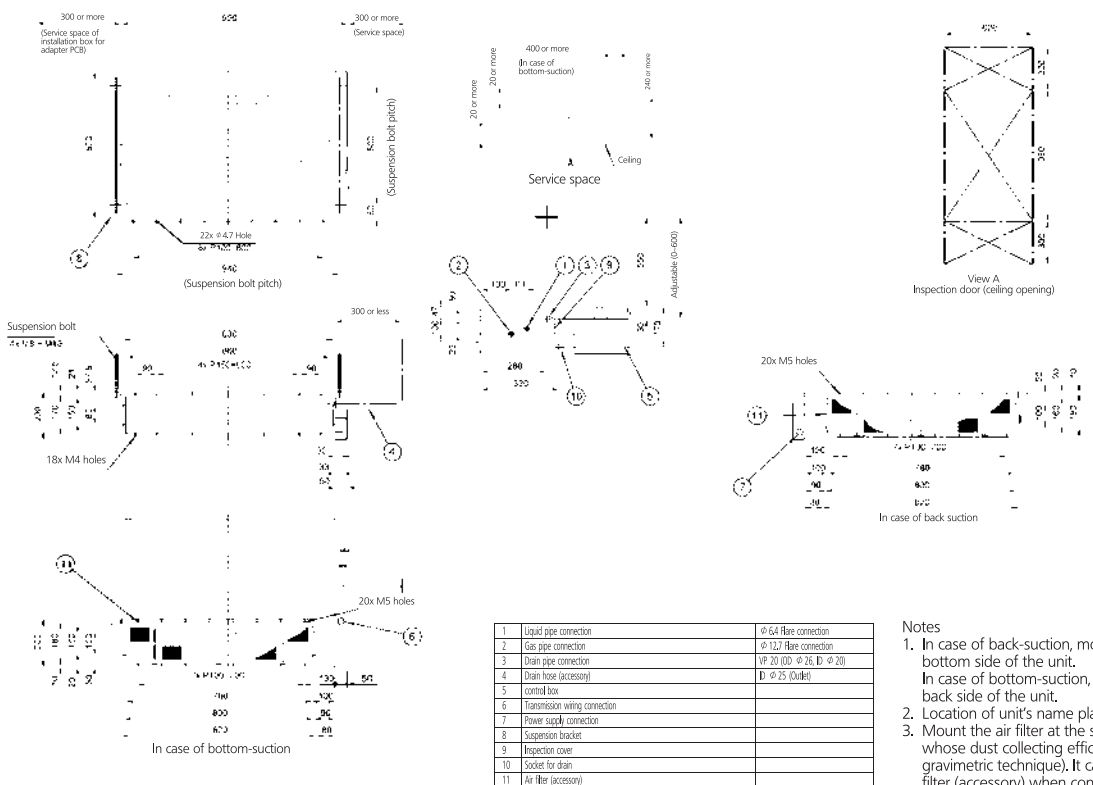

- Notes**
- In case of back-suction, mount chamber cover to bottom side of the unit.
In case of bottom-suction, mount chamber cover to back side of the unit.
 - Location of unit's name plate: control box cover.
 - Mount the air filter at the suction side. (Use an air filter whose dust collecting efficiency is at least 50% in a gravimetric technique). It can not be equipped with air filter (accessory) when connecting duct to suction side.

FXDQ63A

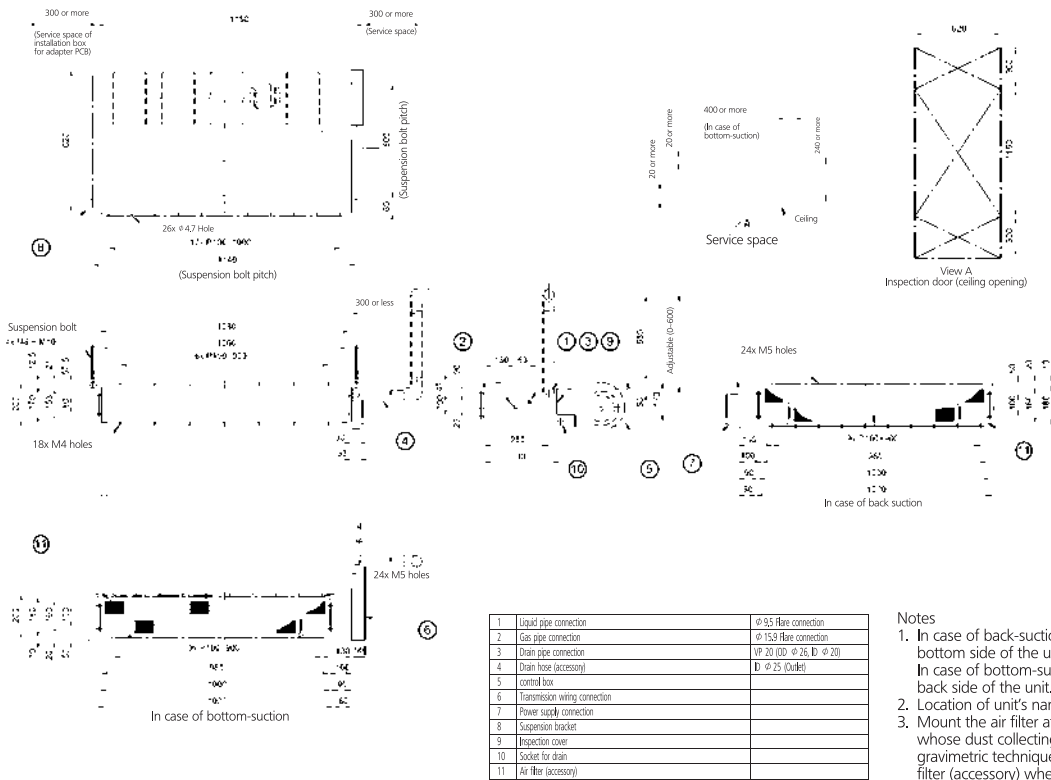

Notes

1. In case of back-suction, mount chamber cover to bottom side of the unit.
In case of bottom-suction, mount chamber cover to back side of the unit.
2. Location of unit's name plate: control box cover.
3. Mount the air filter at the suction side. (Use an air filter whose dust collecting efficiency is at least 50% in a gravimetric technique). It can not be equipped with air filter (accessory) when connecting duct to suction side.

FXQQ15A

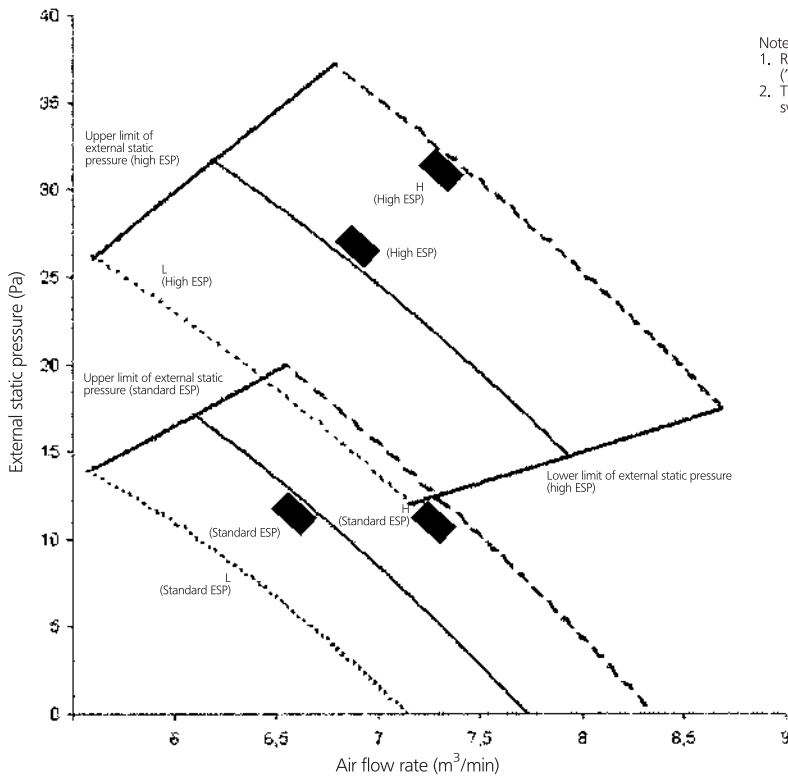

Notes:

1. Remote controller can be used to switch between 'HIGH' and 'LOW'. ('H', 'M' and 'L' for FXDQ-A2VEB model)
2. The air flow is set to 'STANDARD' before leaving the factory. It is possible to switch between 'STANDARD ESP' and 'HIGH ESP' by remote controller.

FXDQ20-25A

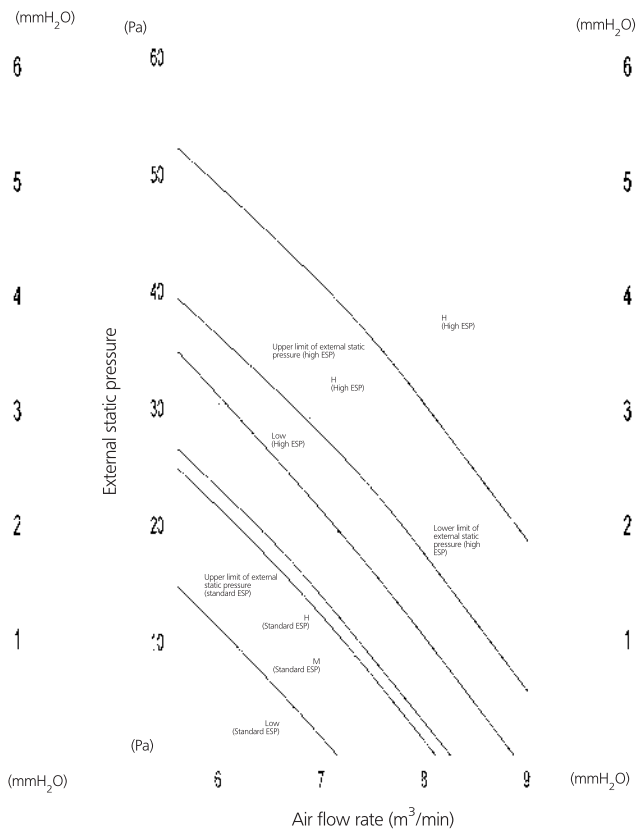

- Notes:
1. Remote controller can be used to switch between 'HIGH' and 'LOW'. ('H', 'M' and 'L' for FXDQ-A2VEB model)
 2. The air flow is set to 'STANDARD' before leaving the factory. It is possible to switch between 'STANDARD ESP' and 'HIGH ESP' by remote controller.

Indoor Units

FXDQ40A



- Notes:
1. Remote controller can be used to switch between 'HIGH' and 'LOW'. ('H', 'M' and 'L' for FXDQ-A2VEB model)
 2. The air flow is set to 'STANDARD' before leaving the factory. It is possible to switch between 'STANDARD ESP' and 'HIGH ESP' by remote controller.

FXDQ50A

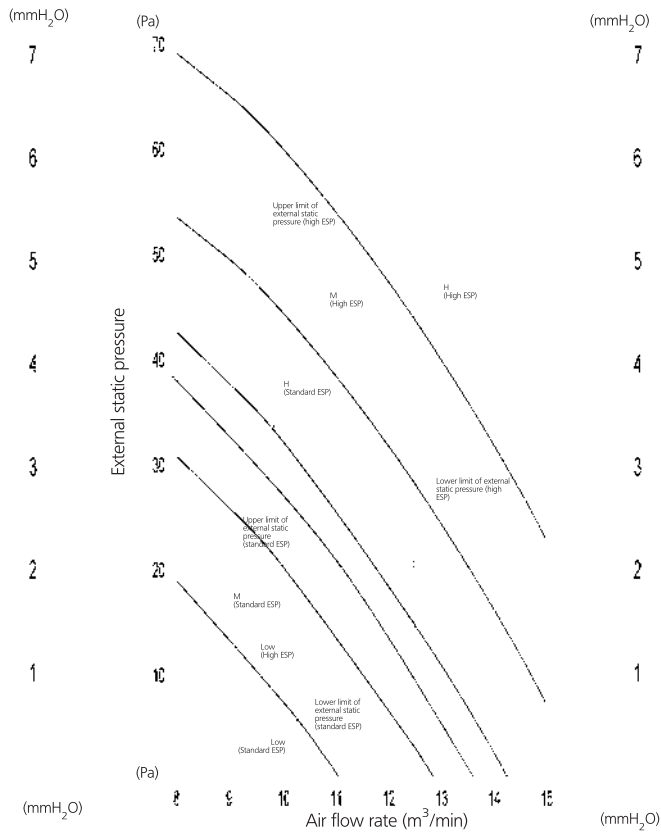

- Notes:
1. Remote controller can be used to switch between 'HIGH' and 'LOW'. ('H', 'M' and 'L' for FXDQ-A2VEB model)
 2. The air flow is set to 'STANDARD' before leaving the factory. It is possible to switch between 'STANDARD ESP' and 'HIGH ESP' by remote controller.

FXDQ63A

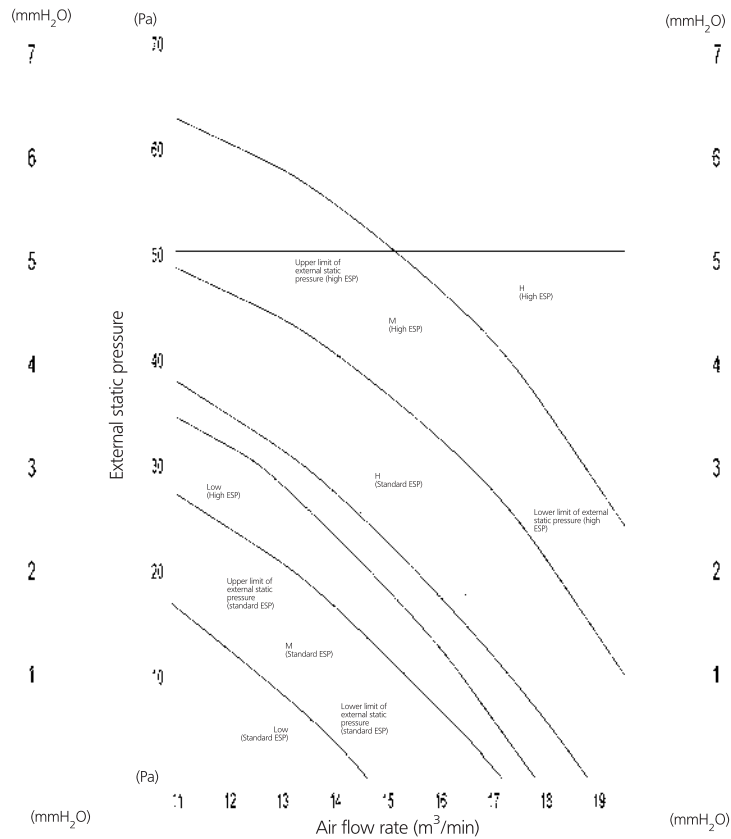

- Notes:
1. Remote controller can be used to switch between 'HIGH' and 'LOW'. ('H', 'M' and 'L' for FXDQ-A2VEB model)
 2. The air flow is set to 'STANDARD' before leaving the factory. It is possible to switch between 'STANDARD ESP' and 'HIGH ESP' by remote controller.



Concealed ceiling unit with medium ESP

Slimmest yet most powerfull medium static pressure unit on the market

Unique features for FXSQ-A:

- > Slimmest unit in class, only 245mm (295mm built-in height)
- > Low operating sound level
- > Medium external static pressure up to 150Pa facilitates using flexible ducts of varying lengths
- > Automatic air flow adjustment function measures the air volume and static pressure and adjusts it towards the nominal air flow, whatever the length of duct, making installation easier and guaranteeing comfort. Moreover, the ESP can be changed via the wired remote control to optimize the supply air volume
- > Discretely concealed in the ceiling: only the suction and discharge grilles are visible
- > 15 class unit especially developed for small or well-insulated rooms, such as hotel bedrooms, small offices, etc.
- > Reduced energy consumption thanks to specially developed DC fan motor
- > Fresh air intake integrated in the same system thus reducing installation cost as no additional ventilation is required

Fresh air intake opening in casing

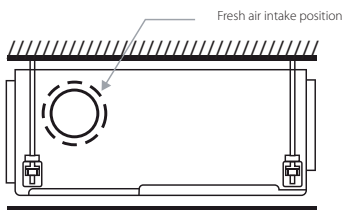

* Brings in up to 10% of fresh air into the room

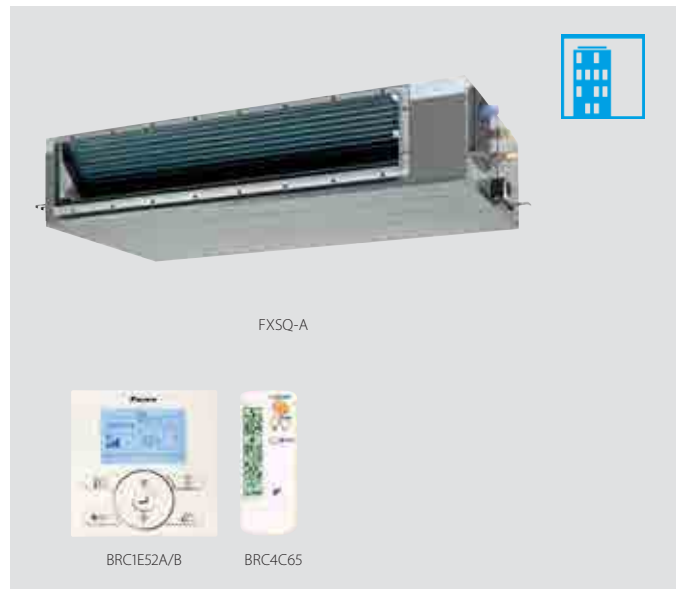

- > Flexible installation
 - air suction direction can be altered from rear to bottom suction

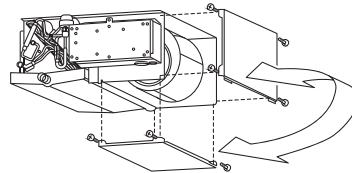

- choice between free use or connection to optional suction grilles

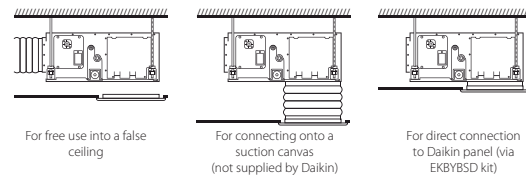

- > Standard built-in drain pump increases flexibility and installation speed

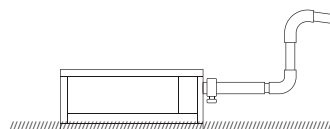



Time saving

Automatic Airflow Adjustment function

- › Automatically selects the most appropriate fan curve to achieve the units' nominal air flow within ±10%
- › Why? After installation the real ducting will frequently differ from the initially calculated air flow resistance; the real air flow may be much lower or higher than nominal, leading to a lack of capacity or uncomfortable air temperature
- › The automatic Airflow Adjustment function will adapt the unit's fan speed to any ducting automatically (10 or more fan curves are available on every model), making installation much faster

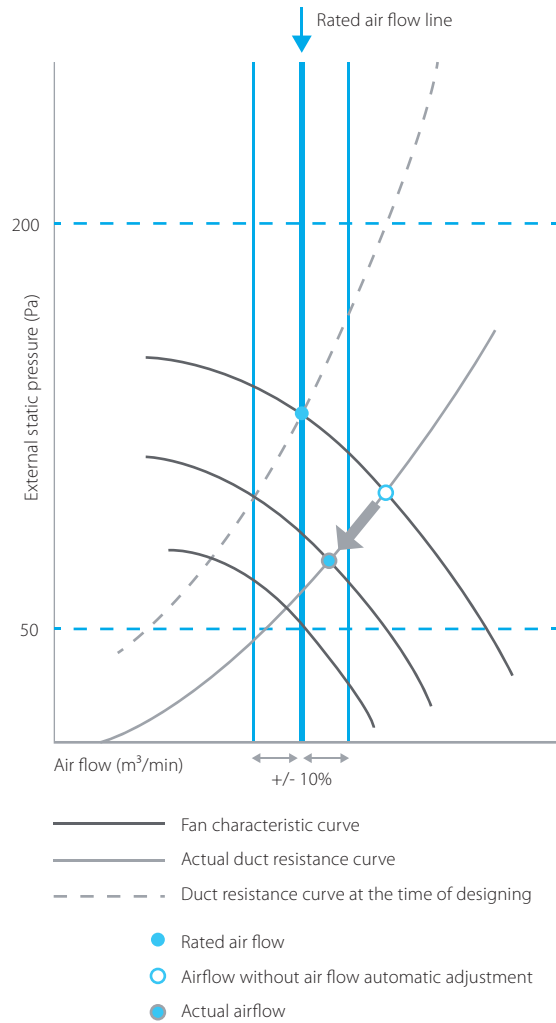

Indoor Units

Indoor unit			FXSQ	15A	20A	25A	32A	40A	50A	63A	80A	100A	125A	140A
Cooling capacity	Nom.	kW	1.7	2.2	2.8	3.6	4.5	5.6	7.1	9.0	11.2	14.0	16.0	
Heating capacity	Nom.	kW	1.9	2.5	3.2	4.0	5.0	6.3	8.0	10.0	10.0	26.0	18.0	
Power input - 50Hz	Cooling	Nom.	41			45	92	95	95	121	157	214	-	
	Heating	Nom.	38			42	89	92	92	118	154	211	-	
Dimensions	Unit	Height	245				245			245		245		245
		Width	550				700			1000		1400		1550
		Depth	800				800			800		800		800
Required ceiling void >		mm	295											
Weight	Unit	kg	23,5			24	28,5	29	35,5	36,5	46	47	51	
Casing	Colour		Not painted											
	Material		Galvanised steel plate											
Decoration panel	Model													
	Colour													
	Dimensions	HeightxWidthxDepth	mm											
	Weight		kg											
Fan-Air flow rate - 50Hz	Cooling	High/Nom./Low	m³/min	8/7/5/65	9/7/5/65	9.5/8/7	15/12.5/11	15/2/12.5/11	21/18/15	23/19.5/16	32/27/23	36/31.5/26	-	
	Heating	High/Nom./Low	m³/min	8/7/5/65	9/7/5/65	9.5/8/7	15/12.5/11	15/2/12.5/11	21/18/15	23/19.5/16	32/27/23	36/31.5/26	-	
Fan-External static pressure - 50Hz	High/Nom.	Pa	150											
Air filter	Type		Resin net with mold resistance											
Sound power level	Cooling	High/Nom.	dB(A)	54			55	60	59	61	61	64	-	
	Heating	High/Nom./Low	dB(A)	29.5/28/25	30/28/25	31/29/26	35/32/29	33/30/27	35/32/29	36/34/31	39/36/33	-		
Sound pressure level	Cooling	High/Nom./Low	dB(A)	31.5/29/26	32/29/26	33/30/27	37/34/29	35/32/28	37/34/30	37/34/31	40/37/33	-		
	Heating	High/Nom./Low	dB(A)											
Refrigerant	Type / GWP		R410A / 2078,5											
Piping connections	Liquid	OD	mm				Ø 6.35 (FLARE)				Ø 9.52 (FLARE)			
	Gas	OD	mm				Ø 12.7 (FLARE)				Ø 15.9 (FLARE)			
	Drain		VP20 (EXTERNAL DIA. 26. INTERNAL DIA. 20), drain height 625 mm											
Power supply	Phase/Frequency/Voltage	Hz/V	50Hz 220-240V											
Current - 50Hz	Maximum fuse amps (MFA)	A	16											
Control systems	Infrared remote control		BRC4C65											
	Simplified wired remote control for hotel applications		BRC2E52C (heat recovery type) / BRC3E52C (heat pump type)											
	Wired remote control		BRC1D52 / BRC1E52A/B											

Concealed ceiling unit with high ESP

Ideal for large sized spaces

FXMQ-P: ESP up to 200

- › Automatic air flow adjustment function measures the air volume and static pressure and adjusts it towards the nominal air flow, whatever the length of duct, making installation easier and guaranteeing comfort. Moreover, the ESP can be changed via the wired remote control to optimize the supply air volume
- › High external static pressure up to 200Pa facilitates extensive duct & grille network.
- › Discretely concealed in the ceiling: only the suction and discharge grilles are visible
- › Reduced energy consumption thanks to specially developed DC fan motor
- › Fresh air intake integrated in the same system thus reducing installation cost as no additional ventilation is required



Fresh air intake opening in casing

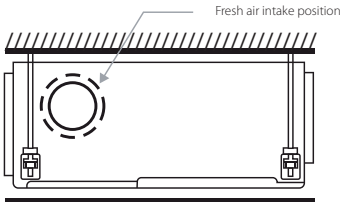

* Brings in up to 10% of fresh air into the room

- › Flexible installation
- air suction direction can be altered from rear to bottom suction

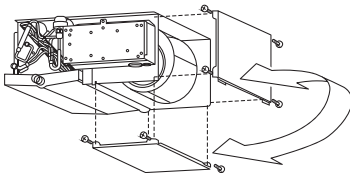

- choice between free use or connection to optional suction grilles

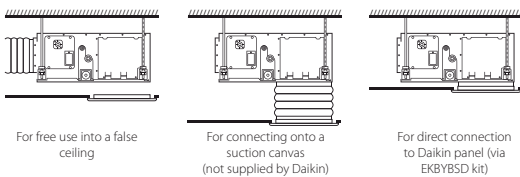

- › Standard built-in drain pump increases flexibility and installation speed

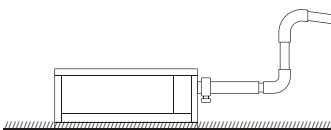

FXMQ-MA9: ESP up to 270

- › High external static pressure up to 270Pa facilitates extensive duct & grille network
- › Discretely concealed in the ceiling: only the suction and discharge grilles are visible
- › Large capacity unit: up to 31.5 kW heating capacity



Time saving

Automatic Airflow Adjustment function

- › Automatically selects the most appropriate fan curve to achieve the units' nominal air flow within $\pm 10\%$
- › Why? After installation the real ducting will frequently differ from the initially calculated air flow resistance; the real air flow may be much lower or higher than nominal, leading to a lack of capacity or uncomfortable air temperature
- › The automatic Airflow Adjustment function will adapt the unit's fan speed to any ducting automatically (10 or more fan curves are available on every model), making installation much faster

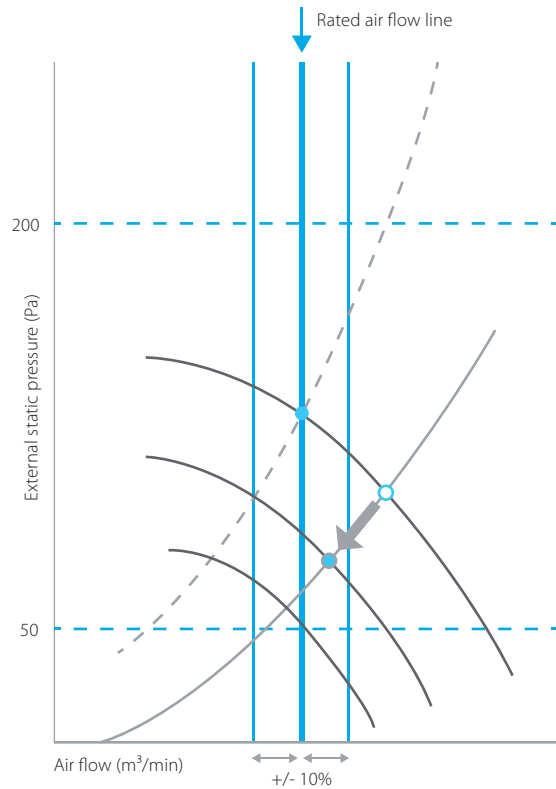

- Fan characteristic curve
- Actual duct resistance curve
- - - Duct resistance curve at the time of designing
- Rated air flow
- Airflow without air flow automatic adjustment
- Actual airflow

Indoor Units

Indoor unit			FXMQ-P7/FXMQ-MA9	50P7	63P7	80P7	100P7	125P7	200MA9	250MA9
Cooling capacity	Nom.	kW	5.6	7.1	9.0	11.2	14.0	22.4	28.0	
Heating capacity	Nom.	kW	6.3	8.0	10.0	12.5	16.0	25.0	31.5	
Power input - 50Hz	Cooling	Nom.	kW	0.110	0.120	0.171	0.176	0.241	1.294	1.465
	Heating	Nom.	kW	0.098	0.108	0.159	0.164	0.229	1.294	1.465
Dimensions	Unit	Height	mm	300					470	
		Width	mm	1,000		1,400		1,380		
		Depth	mm	700			1,100			
Required ceiling void >		mm	350							
Weight	Unit	kg	35			46		137		
Casing	Colour		Unpainted							
	Material		Galvanised steel plate							
Decoration panel	Model		BYBS71DJW1				BYBS125DJW1			
	Colour		White (10Y9/0.5)							
	Dimensions	HeightxWidthxDepth	mm	55x1,100x500			55x1,500x500		-x-x-	
	Weight		kg	4.5			6.5			
Fan-Air flow rate - 50Hz	Cooling	High/Nom./Low	m ³ /min	18/16.5/15	19.5/17.8/16	25/22.5/20	32/27.5/23	39/33.5/28	58/-/50	72/-/62
	Heating	High/Nom./Low	m ³ /min	18/16.5/15	19.5/17.8/16	25/22.5/20	32/27.5/23	39/33.5/28	-/-	-/-
Fan-External static pressure - 50Hz	High/Nom.	Pa	200/100					221/132		270/191
Air filter	Type		Resin net with mold resistance							
Sound power level	Cooling	High/Nom.	dB(A)	61/-	64/-	67/-	65/-	70/-	-/-	
Sound pressure level	Cooling	High/Nom./Low	dB(A)	41/39/37	42/40/38	43/41/39		44/42/40	48/-/45	
	Heating	High/Nom./Low	dB(A)	41/39/37	42/40/38	43/41/39		44/42/40	-/-	
Refrigerant	Type / GWP		R-410A / 2.087,5							
Piping connections	Liquid	OD	mm	6.35	9.52					
	Gas	OD	mm	12.7	15.9			19.1	22.2	
	Drain			VP25 (I.D. 25/O.D. 32)				PS1B		
Power supply	Phase/Frequency/Voltage	Hz/V	1~/50/60/220-240/220							
Current - 50Hz	Maximum fuse amps (MFA)	A	16					15		
Control systems	Infrared remote control		BRC4C65							
	Simplified wired remote control for hotel applications		BRC2E52C (heat recovery type) / BRC3E52C (heat pump type)							
	Wired remote control		BRC1D52 / BRC1E52A/B							

FXMQ50P7

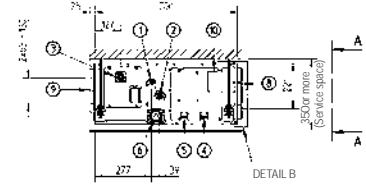
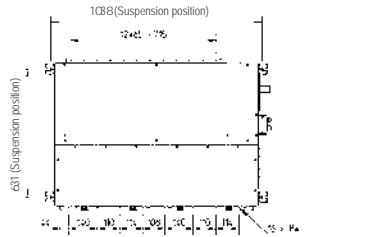
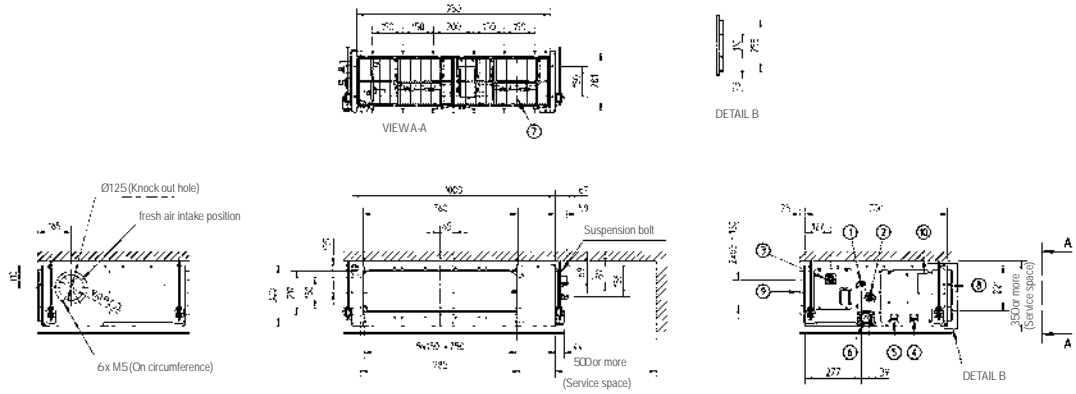

Item	Name	Description
1	Liquid pipe connection	Ø6.35 Flare connection
2	Gas pipe connection	Ø12.70 Flare connection
3	Drain pipe connection	VP25 (OD Ø32, ID Ø25)
4	Remote control wiring connection	-
5	Power supply connection	-
6	Drain hole	VP20 (OD Ø32, ID Ø25)
7	Air filter	-
8	Air suction side	-
9	Air discharge side	-
10	Nameplate	-

3TW32694-1

NOTES

- 1 Refer to 'outlook drawing for installing optional accessories' when installing optional accessories.
- 2 The required ceiling depth varies according to the configuration of the specific system.
- 3 For maintenance of the air filter, it is necessary to provide a service access panel. Refer to the 'filter installation method' drawing.

FXMQ63-80P7

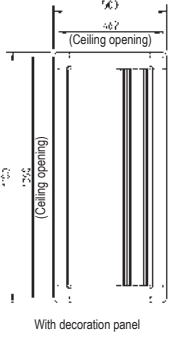
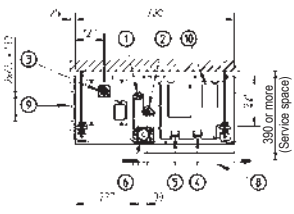
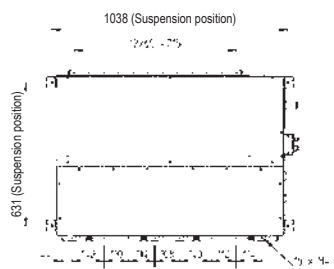
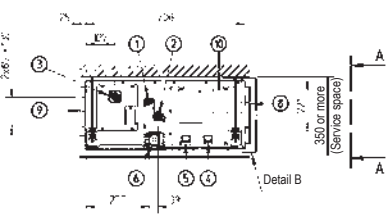
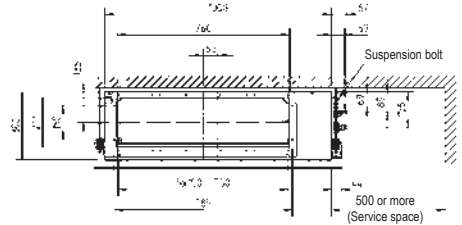
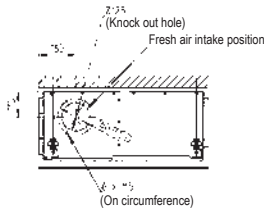

Item	Name	Description
1	Liquid pipe connection	ø 9.52 Flare connection
2	Gas pipe connection	ø 15.90 Flare connection
3	Drain pipe connection	VP25 (OD ø 32, ID ø 25)
4	Remote control wiring connection	-
5	Power supply connection	-
6	Drain hole	VP25 (OD ø 32, ID ø 25)
7	Air filter	-
8	Air suction side	-
9	Air discharge side	-
10	Nameplate	-

NOTES

1. Refer to the outlook drawing of optional accessories when installing them.
2. The required ceiling depth varies according to the configuration of the specific system.
3. For maintenance of the air filter, it is necessary to provide a service access panel.
4. Optional decoration panel: BYBS71DJW1 (light ivory white 10Y9/0.5)

FXMQ100-125P7

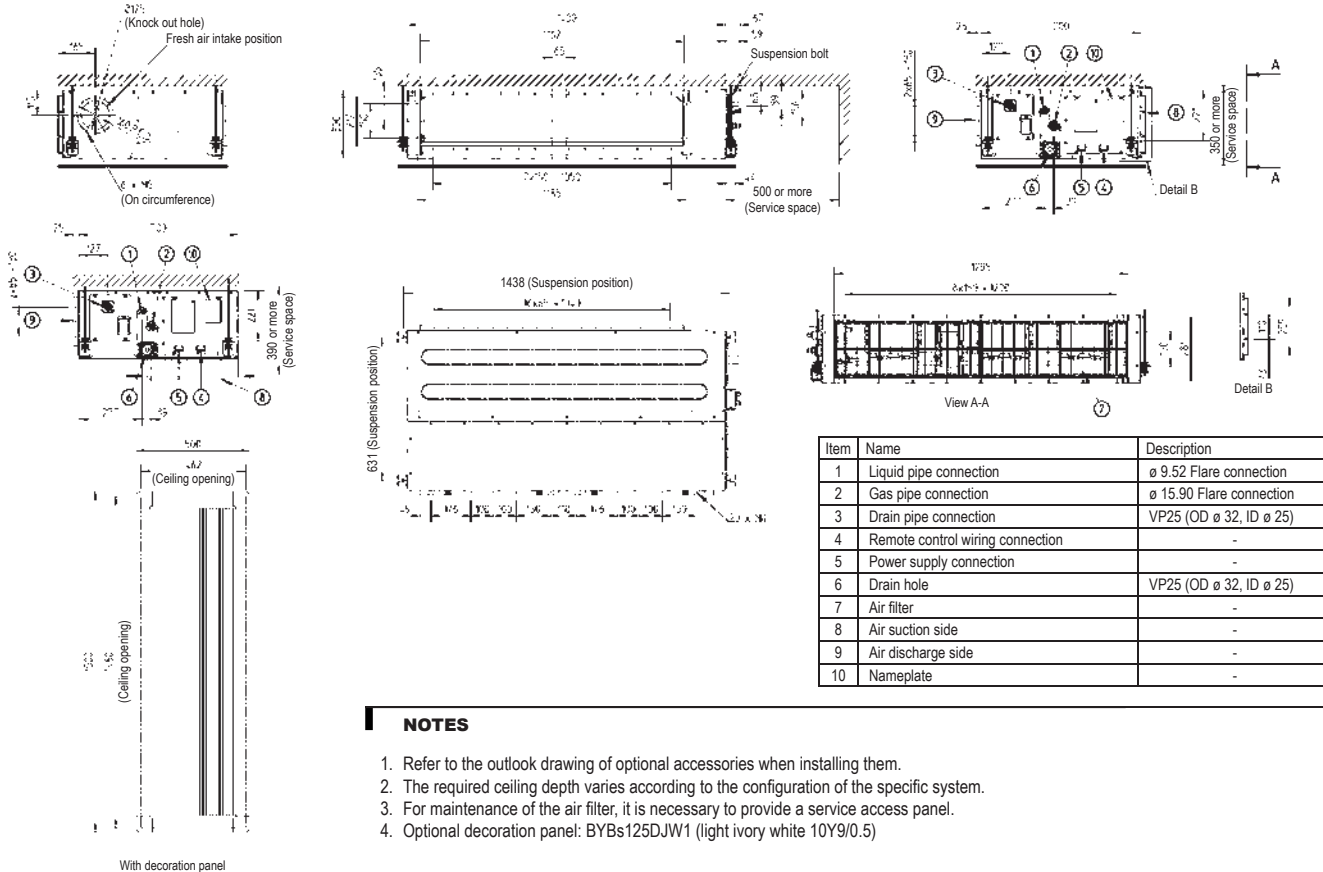

3TW31254-1B

Indoor Units

FXMQ200-250MA9

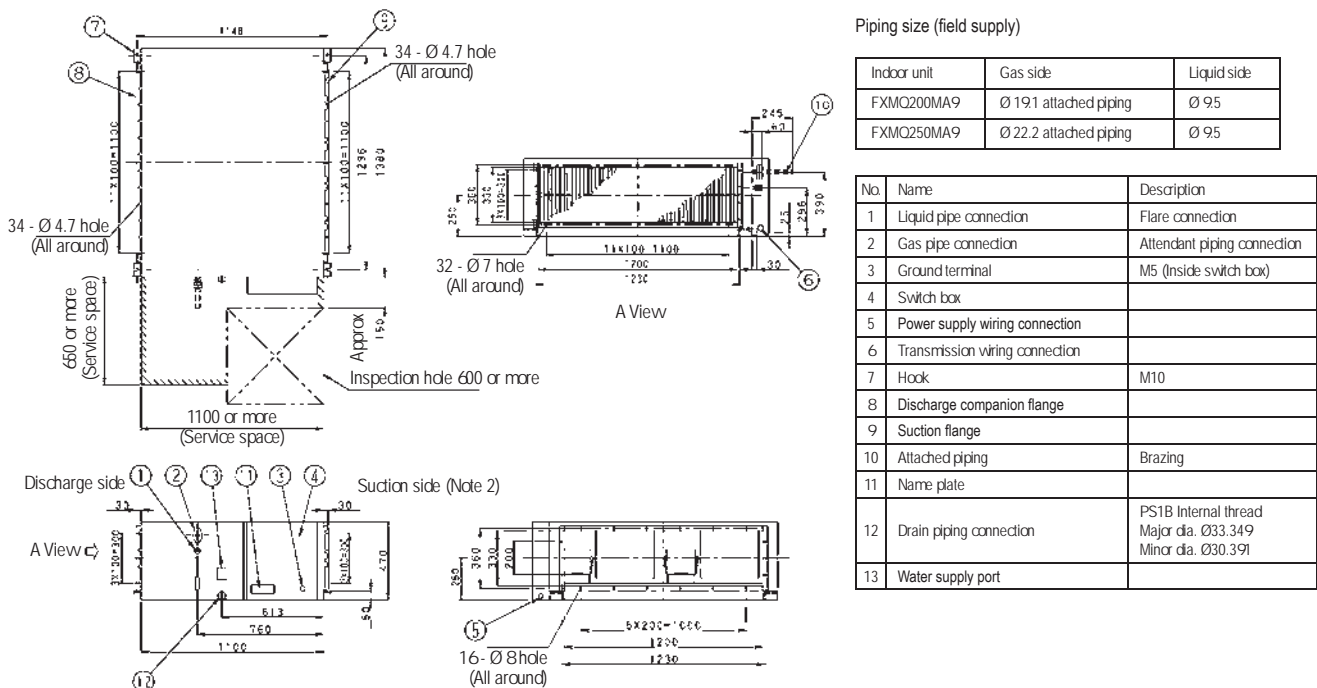

3D038851A

FXMQ50P7

Fan characteristics (1)

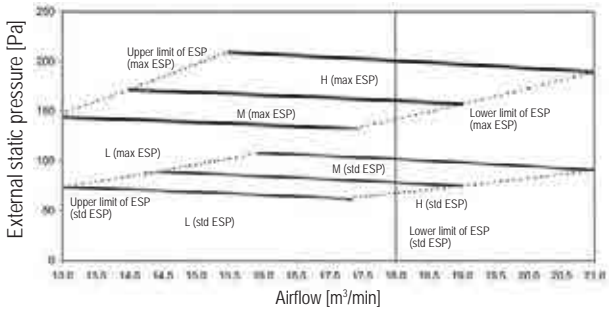

Fan characteristics (3)
(airflow auto adjustment)

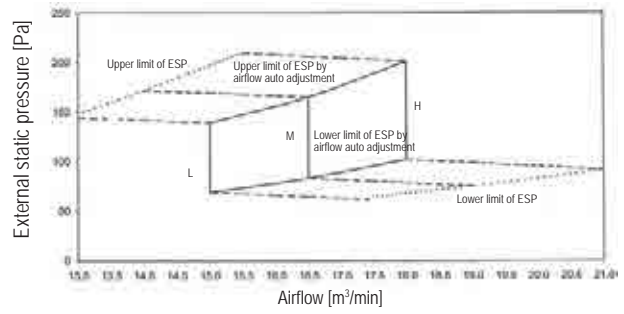

Fan characteristics (2)
(Field setting with remote control)

Range of available air flow rate (H)

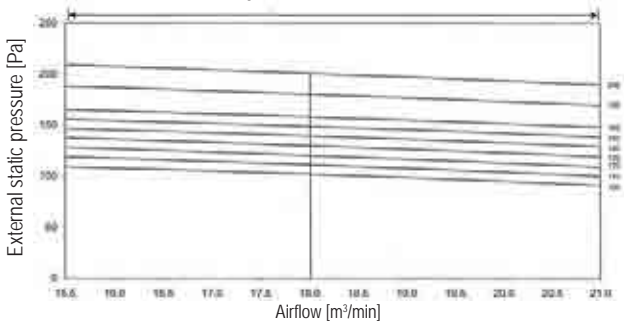

3TW32698-1

NOTES

1. Fan characteristics as shown are in "fan only" mode.
2. ESP: External static pressure

FXMQ63P7

Fan characteristics (1)

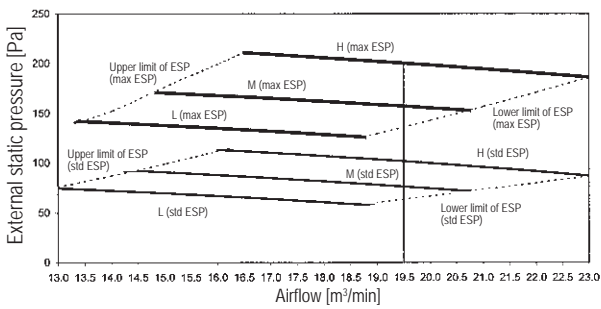

Fan characteristics (3)
(airflow auto adjustment)

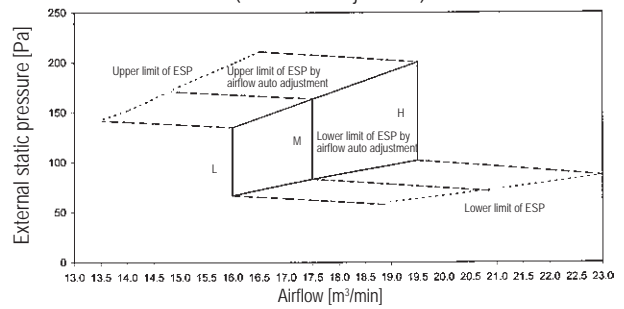

Fan characteristics (2)
(Field setting with remote control)

Range of available air flow rate (H)

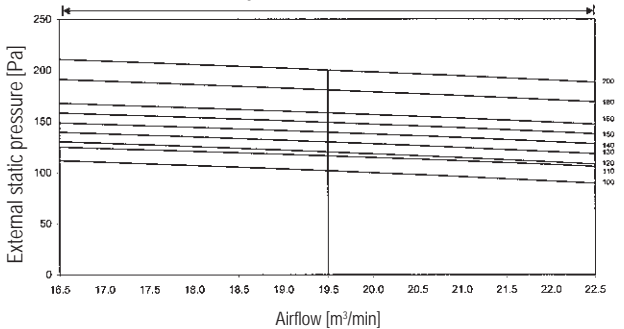

3TW32708-1

NOTES

1. Fan characteristics as shown are in "fan only" mode.
2. ESP: External static pressure

FXMQ80P7

Fan characteristics (1)

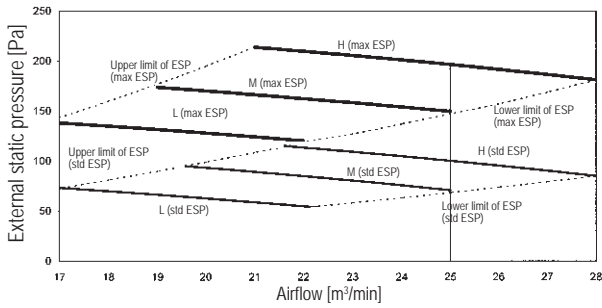

Fan characteristics (3)
(airflow auto adjustment)

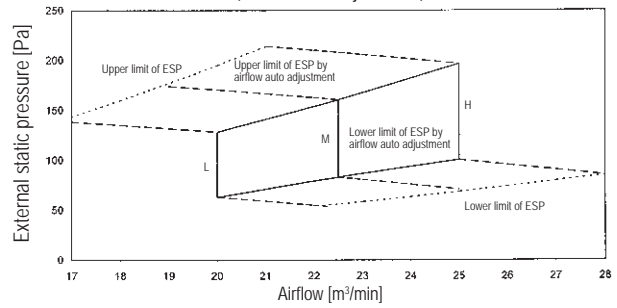

Fan characteristics (2)
(Field setting with remote control)

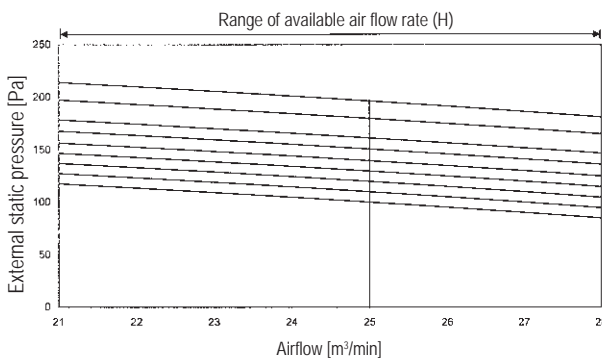

3TW32718-1

NOTES

1. Fan characteristics as shown are in "fan only" mode.
2. ESP: External static pressure

FXMQ100P7

Fan characteristics (1)

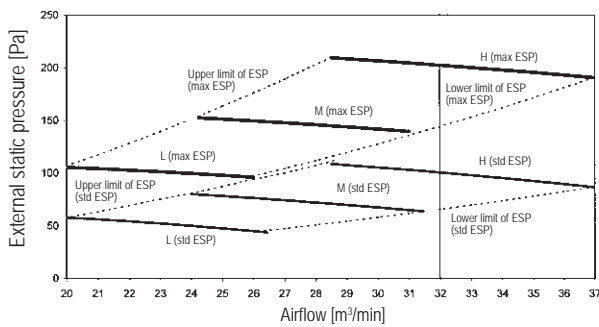

Fan characteristics (3)
(airflow auto adjustment)

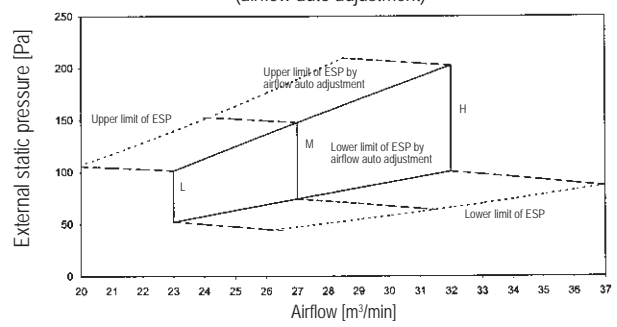

Fan characteristics (2)
(Field setting with remote control)

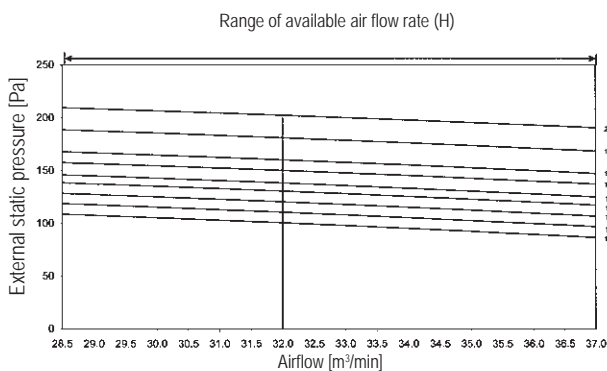

3TW32728-1

NOTES

1. Fan characteristics as shown are in "fan only" mode.
2. ESP: External static pressure.

FXMQ125P7

Fan characteristics (1)

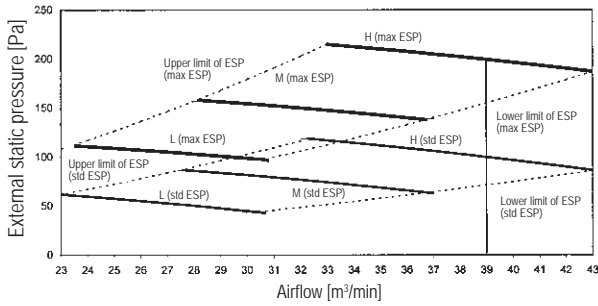

Fan characteristics (3)
(airflow auto adjustment)

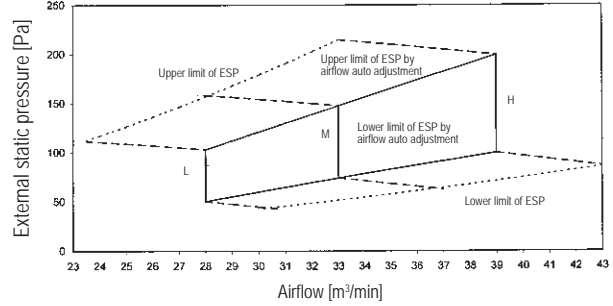

Fan characteristics (2)
(Field setting with remote control)

Range of available air flow rate (H)

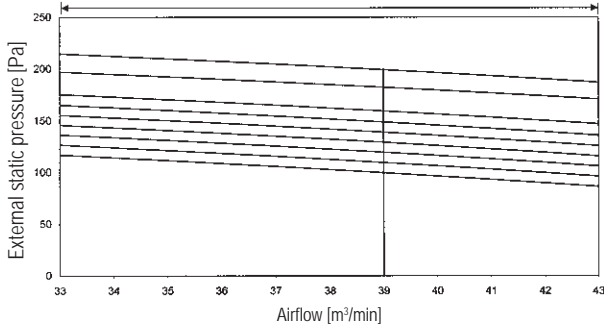

3TW32738-1

NOTES

1. Fan characteristics as shown are in "fan only" mode.
2. ESP: External static pressure

FXMQ200MA

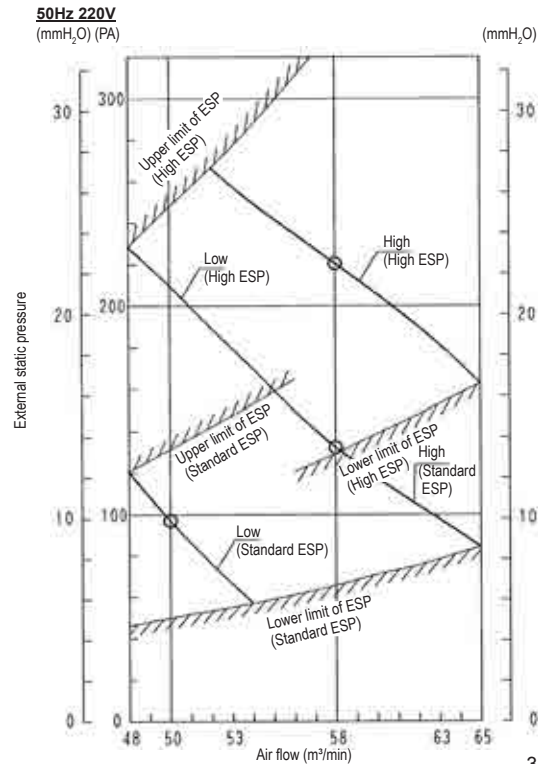

3D035172

NOTES

1. The remote control can be used to switch between "high" and "low".
2. The air flow is set to "standard" before leaving the factory. It is possible to switch between "standard ESP" and "high ESP" by changing the switch in the indoor unit electrical box.

FXMQ250MA

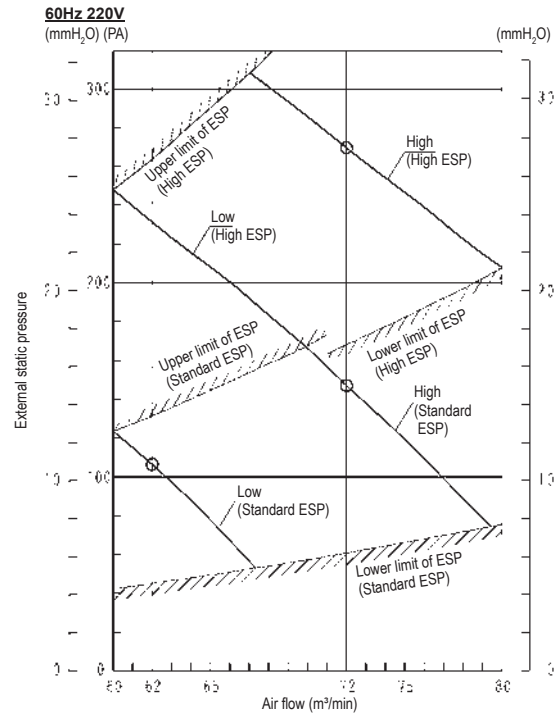

3D035173A

NOTES

1. The remote control can be used to switch between "high" and "low".
2. The air flow is set to "standard" before leaving the factory. It is possible to switch between "standard ESP" and "high ESP" by changing the switch in the indoor unit electrical box.

Concealed ceiling unit

For the highest energy efficiency

- › Automatic air flow adjustment function measures the air volume and static pressure and adjusts it towards the nominal air flow, whatever the length of duct, making installation easier and guaranteeing comfort. Moreover, the ESP can be changed via the wired remote control to optimize the supply air volume (for 50 and 63 class)
- › Narrow ceilings voids are no longer a challenge, 50 & 60 class units can swiftly be integrated as they only are 245mm in height.
- › High external static pressure up to 270Pa facilitates using flexible ducts of varying lengths
- › Discretely concealed in the ceiling: only the suction and discharge grilles are visible

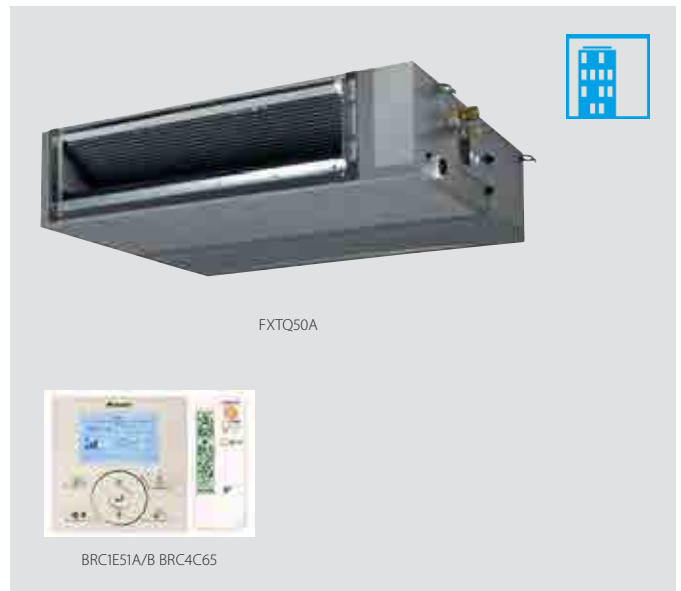

Indoor unit			FXTQ	50A	63A	80A	100A
Cooling capacity	Nom.		kW	5.6	7.1	8.7	11.2
Heating capacity	Nom.		kW	6.3	8.0	10.0	12.5
Power input - 50Hz	Cooling	Nom.	kW	0.214	0.243	1.294	1.465
	Heating	Nom.	kW	0.211	0.240	1.294	1.465
Dimensions	Unit	Height	mm	245		470	
		Width	mm	1,400	1,550	1,380	
		Depth	mm	800		1,100	
Weight	Unit		kg	47	51	137	
Casing	Material	Galvanised steel plate					
Fan-Air flow rate - 50Hz	Cooling	High/Low	m ³ /min	36/26	39/28	58/50	72/62
Fan-External static pressure - 50Hz	High/Nom.		Pa	150/50	140/50	221/132	270/191
Sound power level	Cooling	Nom.	dBA	-			
Sound pressure level	Cooling	High/Low	dBA	39/33	42/34	48/45	
Refrigerant	Type	R-410A					
Piping connections	Liquid	OD	mm	9.52			
	Gas	OD	mm	15.9		19.1	22.2
	Drain			VP20		PS1B	
Power supply	Phase/Frequency/Voltage		Hz/V	1~/50/60/220-240/220			
Current - 50Hz	Maximum fuse amps (MFA)		A	16		15	
Control systems	Infrared remote control	BRC4C65					
	Simplified wired remote control for hotel applications	BRC2E52C (heat recovery) / BRC3E52C (heat pump)					
	Wired remote control	BRC1D52 / BRC1E52A/B					

Only connectable to REYQ8-16T, RYYQ8-16T, RXYQ8-16T(9)

Wall mounted unit

For rooms with no false ceilings nor free floor space

- › Flat front panel blends easily within any interior décor and is more easy to clean
- › Can easily be installed in both new and refurbishment projects
- › 15 class unit especially developed for small or well-insulated rooms, such as hotel bedrooms, small offices, etc.
- › Reduced energy consumption thanks to specially developed DC fan motor
- › The air is comfortably spread up and downwards thanks to 5 different discharge angles that can be programmed via the remote control
- › Maintenance operations can be performed from the front of the unit



Indoor unit			FXAQ	15P	20P	25P	32P	40P	50P	63P
Cooling capacity	Nom.		kW	1.7	2.2	2.8	3.6	4.5	5.6	7.1
Heating capacity	Nom.		kW	1.9	2.5	3.2	4.0	5.0	6.3	8.0
Power input - 50Hz	Cooling	Nom.	kW	0.017	0.019	0.028	0.030	0.020	0.033	0.050
	Heating	Nom.	kW	0.025	0.029	0.034	0.035	0.020	0.039	0.060
Dimensions	Unit	Height	mm	290						
		Width	mm	795				1,050		
		Depth	mm	238						
Weight	Unit		kg	11				14		
Casing	Colour			White (3.0Y8.5/0.5)						
Fan-Air flow rate - 50Hz	Cooling	High/Low	m ³ /min	7.0/4.5	7.5/4.5	8/5	8.5/5.5	12/9	15/12	19/14
Air filter	Type			Washable resin net						
Sound power level	Cooling	Nom.	dBA	-						
Sound pressure level	Cooling	High/Low	dBA	34.0/29.0	35.0/29.0	36.0/29.0	37.5/29.0	39.0/34.0	42.0/36.0	47.0/39.0
Refrigerant	Type / GWP			R-410A / 2.087,5						
Piping connections	Liquid	OD	mm	6.35						
	Gas	OD	mm	12.7						
	Drain			VP13 (I.D. 13/O.D. 18)						
Power supply	Phase/Frequency/Voltage		Hz/V	1~/50/220-240						
Current - 50Hz	Maximum fuse amps (MFA)		A	16						
Control systems	Infrared remote control			BRC7E518						
	Simplified wired remote control for hotel applications			-						
	Wired remote control			BRC1E52A/B / BRC1D52						

FXAQ15-32P

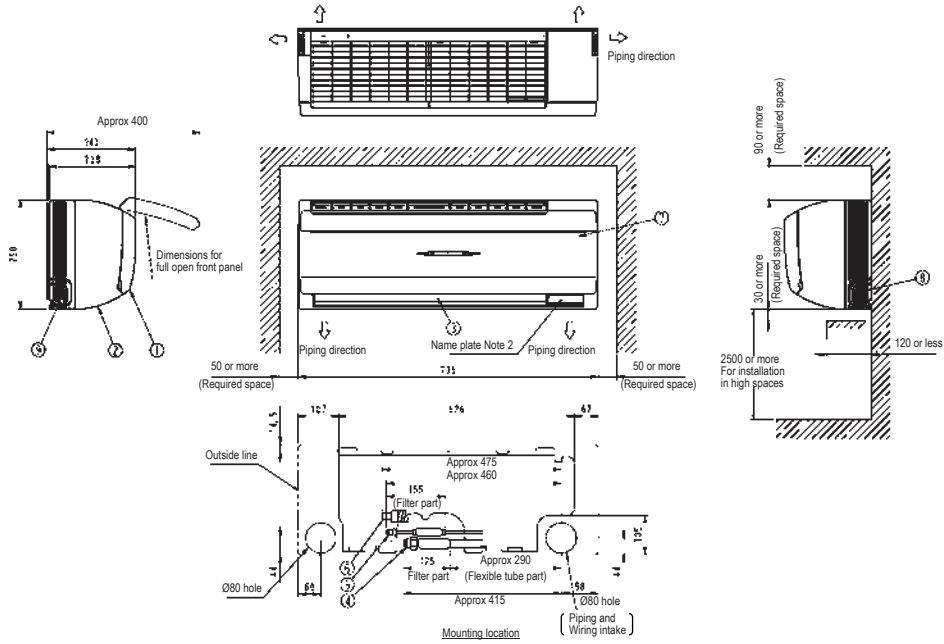

3D065064A

Nr	Name	Description
1	Front panel	
2	Front grill	
3	Air outlet	
4	Gas pipe	Ø12.7mm Flare connection
5	Liquid pipe	Ø6.4mm Flare connection
6	Drain hose	VP13 (External dia. Ø18)
7	Grounding terminal	M4
8	Right side pipe connection hole	
9	Left side pipe connection hole	

NOTES

- 1 Location of unit's of Name Plate: Right side surface of casing.
- 2 In case of using infrared remote control, this position will be a signal receiver. Refer to the drawing of infrared remote control in detail.

FXAQ40-50P

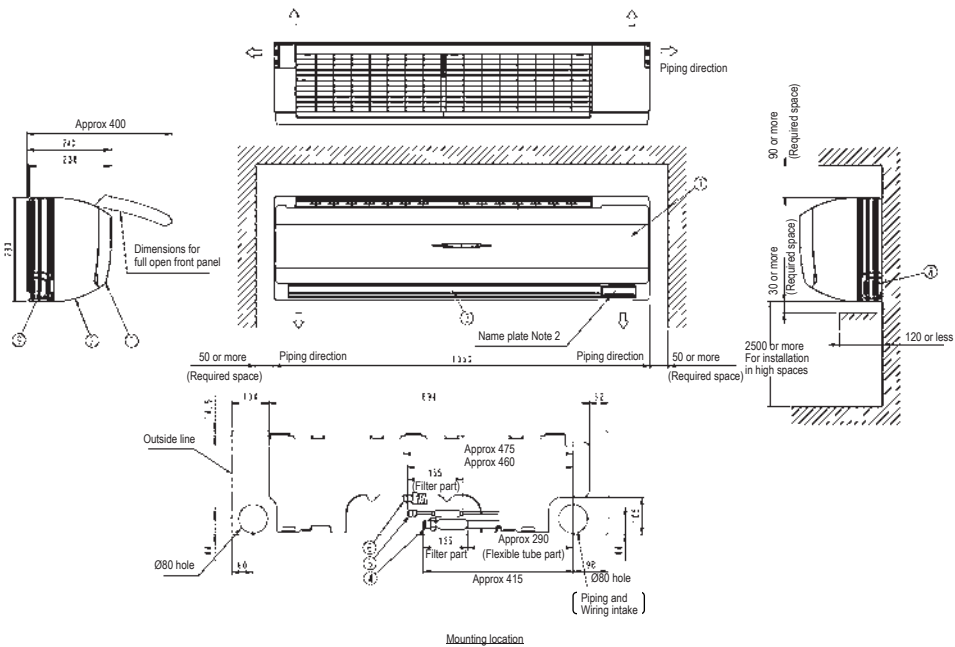

3D065065A

Nr	Name	Description
1	Front panel	
2	Front grill	
3	Air outlet	
4	Gas pipe	Ø12.7mm Flare connection
5	Liquid pipe	Ø6.4mm Flare connection
6	Drain hose	VP13 (External dia. Ø18)
7	Grounding terminal	M4
8	Right side pipe connection hole	
9	Left side pipe connection hole	

NOTES

- 1 Location of unit's of Name Plate: Right side surface of casing.
- 2 In case of using infrared remote control, this position will be a signal receiver. Refer to the drawing of infrared remote control in detail.

FXAQ63P

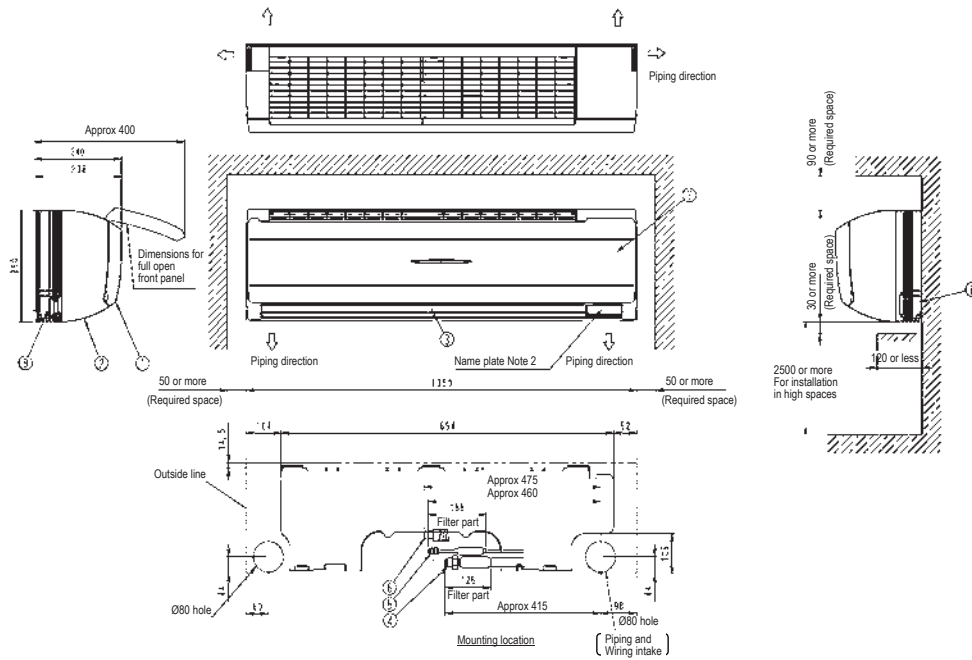

3D065066A

Nr	Name	Description
1	Front panel	
2	Front grill	
3	Air outlet	
4	Gas pipe	Ø15.9mm Flare connection
5	Liquid pipe	Ø9.5mm Flare connection
6	Drain hose	VP13 (External dia. Ø18)
7	Grounding terminal	M4
8	Right side pipe connection hole	
9	Left side pipe connection hole	

NOTES

- 1 Location of unit's of Name Plate: Right side surface of casing.
- 2 In case of using infrared remote control, this position will be a signal receiver. Refer to the drawing of infrared remote control in detail.

Ceiling suspended unit

For wide rooms with no false ceilings nor free floor space

- › Ideal for comfortable air flow in wide rooms thanks to Coanda effect: up to 100° discharge angle

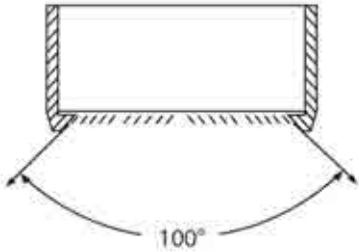

- › Even rooms with ceilings up to 3.8m can be heated up or cooled down very easily without capacity loss
- › Can easily be installed in both new and refurbishment projects
- › Can easily be mounted in corners and narrow spaces, as it only needs 30mm lateral service space

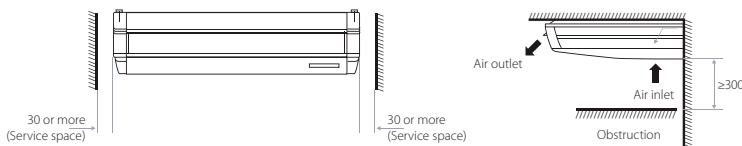

- › Fresh air intake integrated in the same systems thus reducing installation cost as no additional ventilation is required

Fresh air intake opening in casing

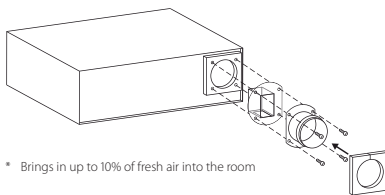

* Brings in up to 10% of fresh air into the room

- › Reduced energy consumption thanks to specially developed DC fan motor and drain pump
- › Stylish unit blends easily with any interior. The flaps close entirely when the unit is not operating



Indoor unit			FXHQ	32A	63A	100A
Cooling capacity	Nom.		kW	3.6	7.1	11.2
Heating capacity	Nom.		kW	4.0	8.0	12.5
Power input - 50Hz	Cooling	Nom.	kW	0.107	0.111	0.237
	Heating	Nom.	kW	0.107	0.111	0.237
Dimensions	Unit	Height	mm	235		
		Width	mm	960	1,270	1,590
		Depth	mm	690		
Weight	Unit		kg	24	33	39
Casing	Colour			Fresh White		
	Material			Resin		
Fan-Air flow rate - 50Hz	Cooling	High/Nom./Low	m ³ /min	14.0/12.0/10.0	20.0/17.0/14.0	29.5/24.0/19.0
	Heating	High/Nom./Low	m ³ /min	14.0/12.0/10.0	20.0/17.0/14.0	29.5/24.0/19.0
Air filter	Type			Resin net with mold resistance		
Sound power level	Cooling	Nom.	dB(A)	-		
Sound pressure level	Cooling	High/Nom./Low	dB(A)	36.0/34.0/31.0	37.0/35.0/34.0	44.0/37.0/34.0
	Heating	High/Nom./Low	dB(A)	36.0/34.0/31.0	37.0/35.0/34.0	44.0/37.0/34.0
Refrigerant	Type / GWP			R-410A / 2.087,5		
Piping connections	Liquid	OD	mm	6.35	9.52	
	Gas	OD	mm	12.7	15.9	
	Drain			VP20 (I.D. 20/O.D. 26)		
Power supply	Phase/Frequency/Voltage		Hz/V	1~/50/220-240		
Current - 50Hz	Maximum fuse amps (MFA)		A	16		
Control systems	Infrared remote control			BRC7G53		
	Simplified wired remote control for hotel applications			-		
	Wired remote control			BRC1E52A/B / BRC1D52		

FXHQ32A

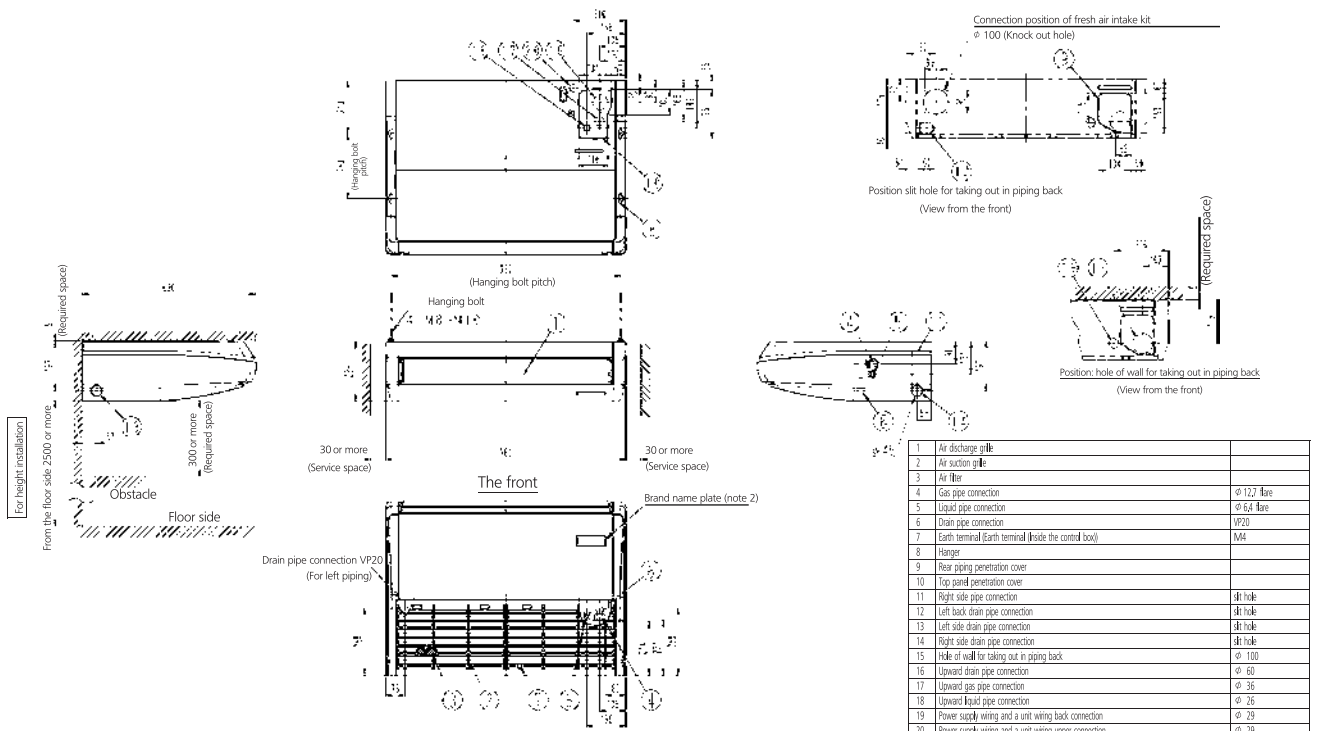

- Note:
1. Location of unit's name plate: bottom of fan housing inside the suction grille.
 2. In case of using infrared remote controller, this position will be a signal receiver. Refer to the drawing of infrared remote controller in detail.
 3. Please do not place the thing been damp and troubled under an indoor unit. When the case where humidity is 80% or more, and the drain outlet are choked up and the air filter are dirty, dew may fall

Indoor Units

FXHQ63A

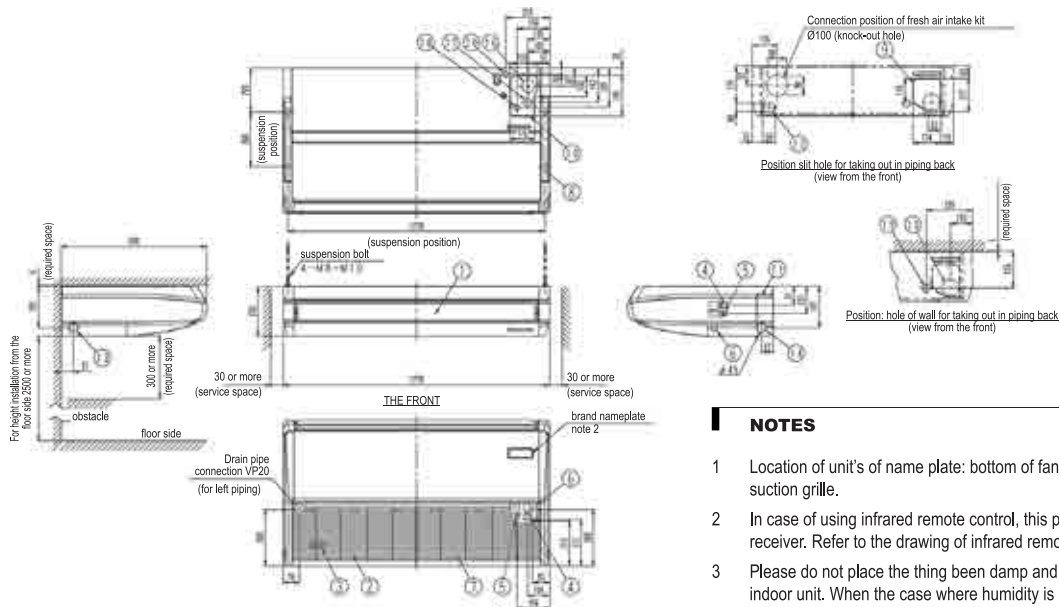

3D069632A

NOTES

- 1 Location of unit's name plate: bottom of fan housing inside the suction grille.
- 2 In case of using infrared remote control, this position will be a signal receiver. Refer to the drawing of infrared remote control in detail.
- 3 Please do not place the thing been damp and troubled under an indoor unit. When the case where humidity is 80% or more, the drain outlet are choked up and the air filter are dirty, dew may fall.

Nr	Name	Description
1	Air discharge grille	
2	Air suction grille	
3	Air filter	
4	Gas pipe connection	Ø15.9 flare
5	Liquid pipe connection	Ø9.5 flare
6	Drain pipe connection	VP20
7	Earth terminal (inside electric components box)	M4
8	Hanger bracket	
9	Backward piping and wiring connection opening lid	
10	Upward piping and wiring connection opening lid	

11	Right side pipe connection	slit hole
12	Left back drain pipe connection	slit hole
13	Left side drain pipe connection	slit hole
14	Right side drain pipe connection	slit hole
15	Hole of wall for taking out in piping back	Ø100
16	Upward drain pipe connection	Ø60
17	Upward gas pipe connection	Ø36
18	Upward liquid pipe connection	Ø26
19	Power source wiring and a unit wiring back connection	Ø29
20	Power source wiring and a unit wiring upper connection	Ø29

4-way blow ceiling suspended unit

Unique Daikin unit for high rooms with no false ceilings nor free floor space

- › Even rooms with ceilings up to 3.5m can be heated up or cooled down very easily without capacity loss
- › Can easily be installed in both new and refurbishment projects
- › Refurbishing the room ? With individual flap control, one or more flaps can be easily closed via the wired remote control

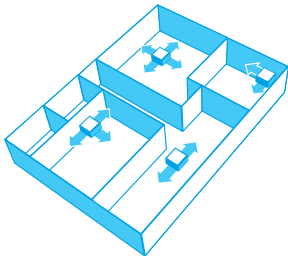

- › Reduced energy consumption thanks to specially developed small tube heat exchanger, DC fan motor and drain pump
- › Stylish unit blends easily with any interior. The flaps close entirely when the unit is not operating
- › Optimum comfort guaranteed with automatic air flow adjustment to the required load
- › 5 different discharge angles between 0 and 60° can be programmed via the remote control

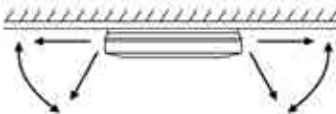

- › Standard drain pump with 500mm lift increases flexibility and installation speed

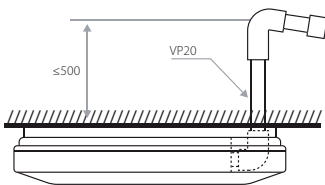

Indoor unit		FXUQ	71A	100A	
Cooling capacity	Nom.	kW	8.0	11.2	
Heating capacity	Nom.	kW	9.0	12.5	
Power input - 50Hz	Cooling	Nom.	0.090	0.200	
	Heating	Nom.	0.073	0.179	
Dimensions	Unit	Height	198		
		Width	950		
		Depth	950		
Weight	Unit	kg	26	27	
Casing	Colour	Fresh White			
	Material	Resin			
Fan-Air flow rate - 50Hz	Cooling	High/Nom./Low	m ³ /min	22.5/19.5/16.0	31.0/26.0/21.0
	Heating	High/Nom./Low	m ³ /min	22.5/19.5/16.0	31.0/26.0/21.0
Air filter	Type	Resin net with mold resistance			
Sound power level	Cooling	Nom.	-		
Sound pressure level	Cooling	High/Nom./Low	dBA	40.0/38.0/36.0	47.0/44.0/40.0
	Heating	High/Nom./Low	dBA	40.0/38.0/36.0	47.0/44.0/40.0
Refrigerant	Type / GWP	R-410A / 2.087,5			
Piping connections	Liquid	OD	mm		
	Gas	OD	mm		
	Drain	I.D. 20/O.D. 26			
Power supply	Phase/Frequency/Voltage	Hz/V			
Current - 50Hz	Maximum fuse amps (MFA)	A			
Control systems	Infrared remote control	BRC7C58			
	Simplified wired remote control for hotel applications	-			
	Wired remote control	BRC1E52A/B / BRC1D52			

FXUQ-A

Note:

1. Location for manufacture's label: On the control box lid inside suction grille.
2. This is where the signal of infrared remote controller is received. Refer to the outside drawing of infrared remote controller in detail.
3. When closing the discharge grill (2 or 3 way discharge), direction of pipe connection will be limited, please refer to installation manual.
4. Please do not place the thing been damp and troubled under an indoor unit. When the case where humidity is 80% or more, and the drain outlet are choked up and the air filter are dirty, dew may fall.

(Unit: mm)

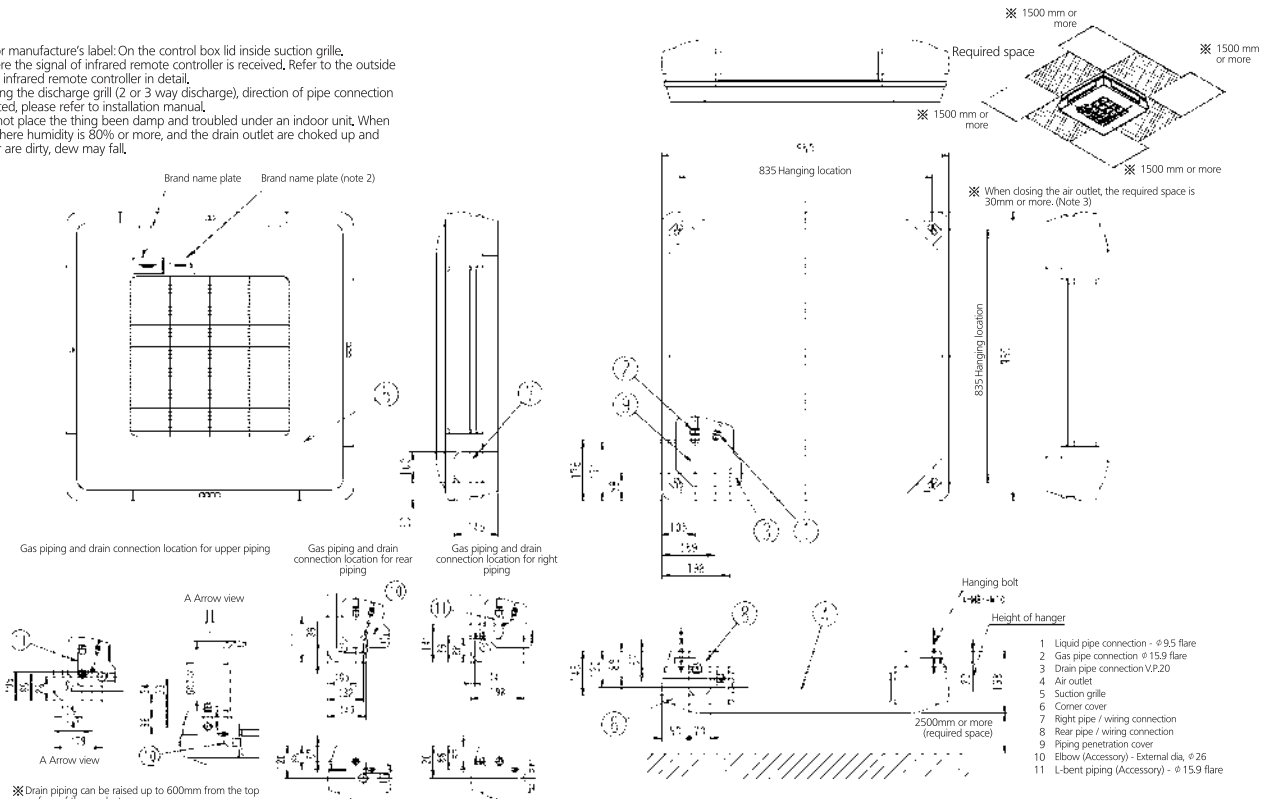

Indoor Units

Concealed floor standing unit

Designed to be concealed in walls

- › High ESP allows flexible installation
- › Its low height enables the unit to fit perfectly beneath a window
- › Blends unobtrusively with any interior décor: only the suction and discharge grilles are visible



- › Requires very little installation space as the depth is only 200mm

Indoor unit		FXNQ	20A	25A	32A	40A	50A	63A
Cooling capacity	Nom.	kW	2.2	2.8	3.6	4.5	5.6	7.1
Heating capacity	Nom.	kW	2.5	3.2	4.0	5.0	6.3	8.0
Power input - 50Hz	Cooling	Nom.	0.071			0.078	0.099	0.110
	Heating	Nom.	0.068			0.075	0.096	0.107
Dimensions	Unit	Height	720 / 620 (1)					
		Width	750		950		1,150	
		Depth	200					
Weight	Unit	kg	22			26		29
		Casing	Color	Unpainted				
		Material	Galvanised steel plate					
Fan-Air flow rate - 50Hz	Cooling	High/Nom./Low	8.0/7.2/6.4			10.5/9.5/8.5	12.5/11/10.0	16.5/14.5/13.0
Fan-External static pressure - 50Hz	High/Nom.	Pa	41/10		42/10	52/15	59/15	55/15
Air filter			Resin net with mold resistance					
Sound power level	Cooling	Nom.	51			52	53	54
		High/Nom./Low	30/28.5/27			32/30/28	33/31/29	35/33/32
Refrigerant	Type / GWP		R-410A / 2.087,5					
Piping connections	Liquid	OD	6.35		9.52			
	Gas	OD	12.7		15.9			
	Drain		VP20 (I.D. 20/O.D. 26)					
Power supply	Phase/Frequency/Voltage	Hz/V	1~/50/60/220-240/220					
Current - 50Hz	Maximum fuse amps (MFA)	A	16					
Control systems	Infrared remote control		BRC4C65					
	Simplified wired remote control for hotel applications		BRC2E52C (heat recovery type) / BRC3E52C (heat pump type)					
	Wired remote control		BRC1D52 / BRC1E52A/B					

(1) Without stands

Floor standing unit

For perimeter zone air conditioning

- › Unit can be installed as free standing model by use of optional back plate
- › Its low height enables the unit to fit perfectly beneath a window
- › Stylish modern casing finished in pure white (RAL9010) and iron grey (RAL7011) blends easily with any interior
- › Requires very little installation space

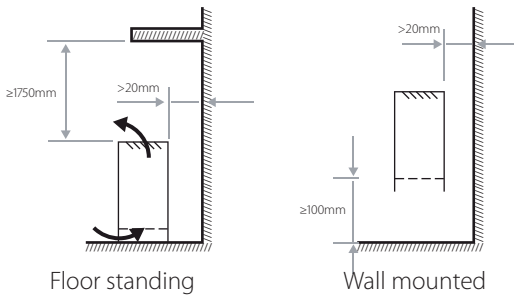

- › Wall mounted installation facilitates cleaning beneath the unit where dust tends to accumulate

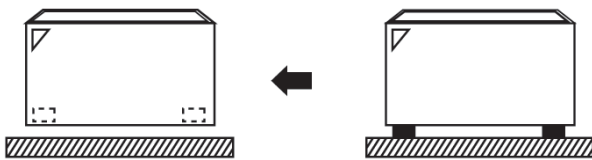

- › Wired remote control can easily be integrated in the unit

Indoor unit			FXLQ	20P	25P	32P	40P	50P	63P
Cooling capacity	Nom.		kW	2.2	2.8	3.6	4.5	5.6	7.1
Heating capacity	Nom.		kW	2.5	3.2	4.0	5.0	6.3	8.000
Power input - 50Hz	Cooling	Nom.	kW	0.049		0.090		0.110	
	Heating	Nom.	kW	0.049		0.090		0.110	
Dimensions	Unit	Height	mm	600					
		Width	mm	1,000		1,140		1,420	
		Depth	mm	232					
		Weight	kg	27		32		38	
Casing	Colour		Fresh white (RAL9010) / Dark grey (RAL7011)						
Fan-Air flow rate - 50Hz	Cooling	High/Low	m ³ /min	7/6		8/6	11/8.5	14/11	16/12
Air filter	Type		Resin net						
Sound power level	Cooling	Nom.	dB(A)	-					
Sound pressure level	Cooling	High/Low	dB(A)	35/32		38/33		39/34	40/35
Refrigerant	Type / GWP		R-410A / 2.087,5						
Piping connections	Liquid	OD	mm	6.35					9.52
	Gas	OD	mm	12.7					15.9
	Drain			O.D. 21 (Vinyl chloride)					
Power supply	Phase/Frequency/Voltage		Hz/V	1~/50/60/220-240/220					
Current - 50Hz	Maximum fuse amps (MFA)		A	15					
Control systems	Infrared remote control			BRC4C65					
	Simplified wired remote control for hotel applications			BRC2E52C (heat recovery type) / BRC3E52C (heat pump type)					
	Wired remote control			BRC1D52 / BRC1E52A/B					

FXLQ20-25P

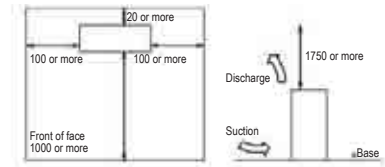
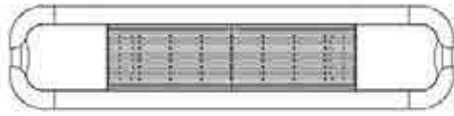

Required installation space

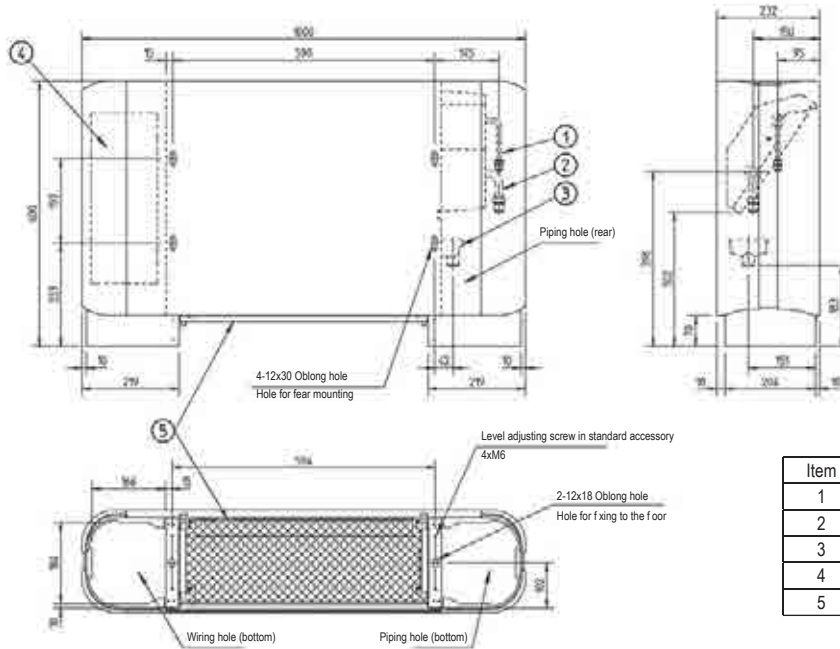

Item	Name	Description
1	Liquid pipe connection	Ø6.4 Flare connection
2	Gas pipe connection	Ø12.7 Flare connection
3	Drain pipe connection	O.D.Ø21
4	Switch box	
5	Air filter	

3TW32294-1

FXLQ32-40P
FXLQ32-40P

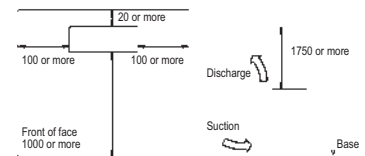

Required installation space

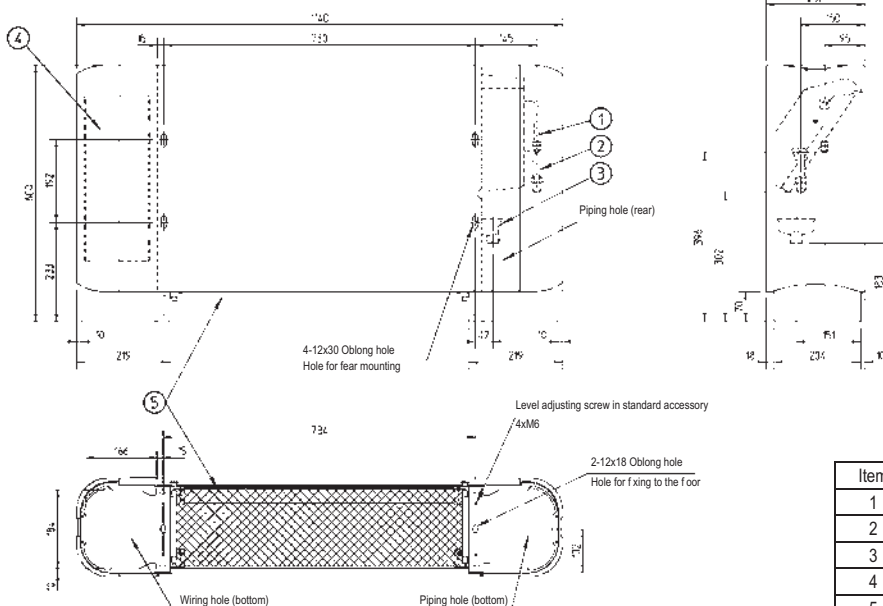

Item	Name	Description
1	Liquid pipe connection	Ø6.4 Flare connection
2	Gas pipe connection	Ø12.7 Flare connection
3	Drain pipe connection	O.D.Ø21
4	Switch box	
5	Air filter	

3TW32314-1

FXLQ50-63P

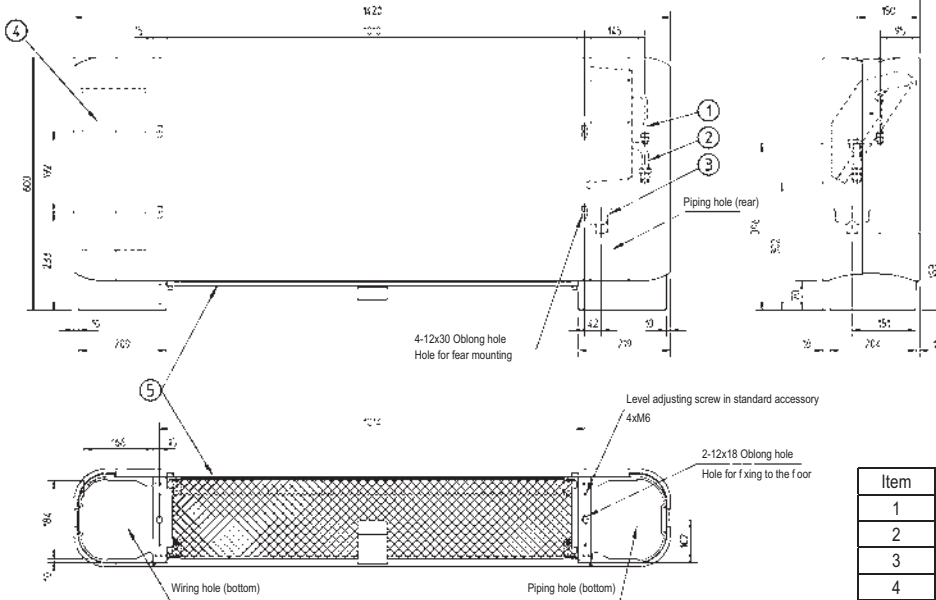
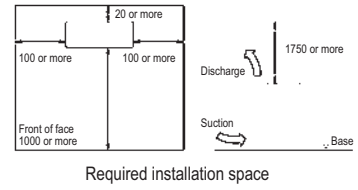
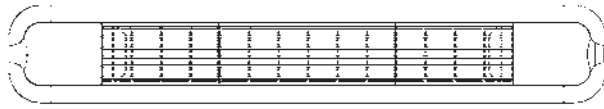

Model	A	B
FXL050	Ø6.4	Ø12.7
FXL063	Ø9.5	Ø15.9

Item	Name	Description
1	Liquid pipe connection	ØA Flare connection
2	Gas pipe connection	ØB Flare connection
3	Drain pipe connection	O.D.Ø21
4	Switch box	
5	Air filter	

3TW32334-1



Stylish indoor units overview

Depending on the application, Split and Sky Air indoor units can be connected to our VRV IV and VRV III-S outdoor units. Refer to the **outdoor unit portfolio** for combination restrictions.

Type	Model	Product name	Image	Capacity class (kW)							Connectable outdoor unit						
				15	20	25	35	42	50	60	71	RYYQ-T	RXYQ-T(9)	RXYSQ-P8V1 ³	RXYSQ-P8Y1 ³		
Ceiling mounted cassette	Round flow cassette <small>(incl. auto-cleaning function)</small>	FCQG-F					●			●	●				✓	✓	
	Fully flat cassette <small>universal design award 2014</small>	FFQ-C					●	●		●	●				✓	✓	
Concealed ceiling	Small concealed ceiling unit	FDBQ-B					●								✓	✓	
	Slim concealed ceiling unit	FDXS-F(9)					●	●		●	●				✓	✓	
	Concealed ceiling unit with inverter-driven fan	FBQ-D						●		●	●				✓	✓	
Wall mounted	Daikin Emura Wall mounted unit <small>reddot award 2014 winner</small>	FTXG-LW/LS				●	●	●		●				✓	✓	✓	✓
	Wall mounted unit	CTXS-K FTXS-K		●	●	●	●	●		●				✓	✓	✓	✓
	Wall mounted unit	FTXS-G									●	●		✓	✓	✓	✓
Ceiling suspended	Ceiling suspended unit	FHQ-C					●			●	●				✓	✓	
	Nexura floor standing unit	FVXG-K					●	●		●				✓	✓	✓	✓
Floor standing	Floor standing unit	FVXS-F					●	●		●				✓	✓	✓	✓
	Flexi type unit	FLXS-B(9)					●	●		●	●			✓	✓	✓	✓

¹ Decoration panel BYCQ140CG + BRC1E52A/B needed
² To connect stylish indoor units a BPMKS unit is needed
³ For RXYSQ units a mix of RA indoor units and VRV indoor units is not allowed.

VRV heatpump combined with stylish indoor units

Combine VRV indoor units with stylish indoor units

on a VRV IV heat pump

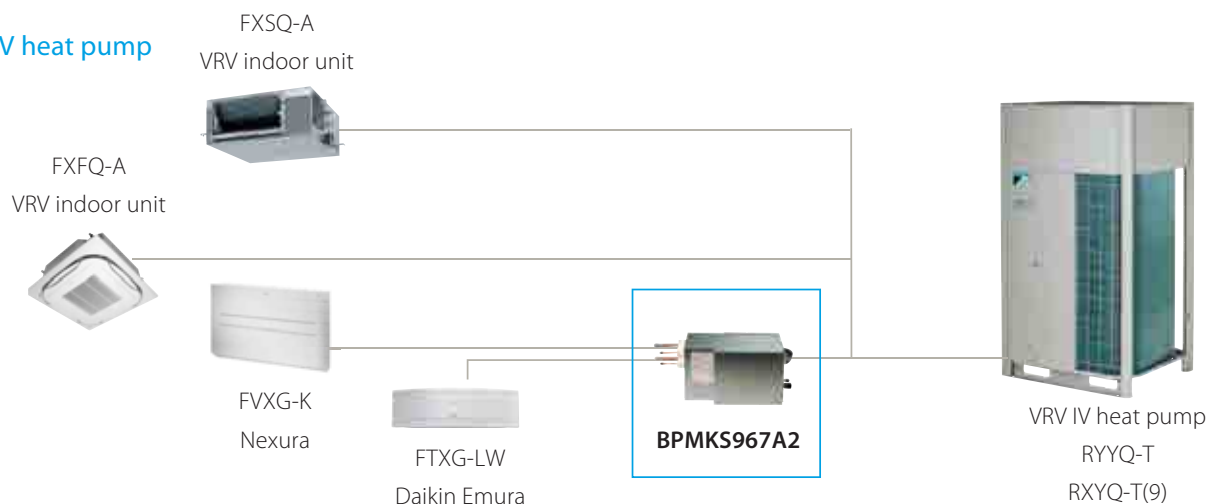

Connect only stylish indoor units to VRV III-S outdoor units

on a VRV III-S heat pump

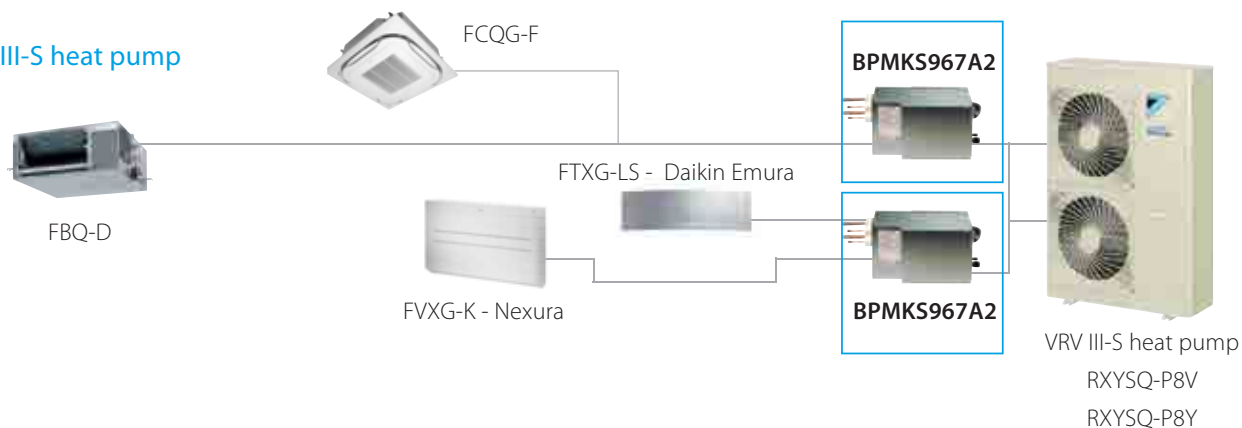

BPMKS967A

Branch provider

To connect Split and Sky Air indoor units to VRV outdoor units



Branch provider			BPMKS967B2	BPMKS967B3
Connectable indoor units			1~2	1~3
Max. indoor unit connectable capacity			14.2	20.8
Max. connectable combination			71+71	60+71+71
Dimensions	Height x Width x Depth	mm	180x294x350	
Weight		kg	7	8

Daikin Emura Form. Function. Redesigned



Why choose Daikin Emura?

- Unique **design**. Designed in Europe for Europe.
- High seasonal **efficiency**, further improved by energy saving techniques like weekly timer and intelligent eye.
- Optimal **comfort** thanks to advanced technologies e.g. 2-area intelligent eye, whisper quiet operation and online controller.



Benefits

- › A remarkable blend between iconic design and engineering excellence
- › Stylish design in matt crystal white and silver
- › Whisper quiet with sound levels down to 19 dBA
- › Horizontal and vertical autoswing
- › 2-area intelligent eye saves energy by reducing the set point if nobody is present and directs airflow away from people, thus avoiding cold draught
- › Weekly timer
- › Online controller:
Always in control no matter where you are



Wall mounted unit

Design at its best, delivering superior efficiency and comfort

- › Seasonal efficiency values up to A+++
- › Remarkable blend of iconic design and engineering excellence with an elegant finish in silver and anthracite or in matt crystal white
- › Designed to perfectly balance technological leadership and the beauty of aerodynamics
- › Online controller (optional): control your indoor from any location with an app, via your local network or internet
- › Whisper quiet in operation: the operating of the unit can hardly be heard. The sound pressure level goes down to 19dBA!



Indoor unit		FTXG	20LW/S	25LW/S	35LW/S	50LW/S
Casing	Colour		White/Silver			
Dimensions	Unit	HeightxWidthxDepth	mm			
			303x998x212			
Weight	Unit		kg			
			12			
Air filter	Type		Removable / washable / mildew proof			
Fan - Air flow rate	Cooling	High/Nom./Low/Silent operation	m ³ /min		10.9/7.8/4.8/2.9	
	Heating	High/Nom./Low/Silent operation	m ³ /min		10.9/8.9/6.8/3.6	
Sound power level	Cooling		dBA		54	
	Heating		dBA		59	
Sound pressure level	Cooling	High/Nom./Low/Silent operation	dBA		56	
	Heating	High/Nom./Low/Silent operation	dBA		59	
Power supply	Phase / Frequency / Voltage	Hz / V	1~ / 50 / 220-240			
	Control systems	Infrared remote control	ARC466A1			



Wall mounted unit

Discreet, modern design for optimal efficiency and comfort thanks to 2 area intelligent eye

- › Discreet, modern design. Its smooth curve blends beautifully with the wall resulting in an unobtrusive presence that matches all interior décors.
- › High quality matt crystal white finish
- › Whisper quiet in operation: the operating of the unit can hardly be heard. The sound pressure level goes down to 19dBA!
- › Ideal for installation in bedrooms (20,25 class) and larger or irregular shaped living areas (35,42,50 class)
- › 2 area intelligent eye: air flow is sent to a zone other than where the person is located at that moment; if no people are detected, the unit will automatically switch over to the energy-efficient setting (FTXS35,42,50K)
- › Online controller (optional): control your indoor from any location with an app, via your local network or internet



Indoor unit		CTXS15K	CTXS35K	FTXS 20K	FTXS 25K	FTXS 35K	FTXS 42K	FTXS 50K	FTXS 60G	FTXS 71G		
Casing	Colour	White										
Dimensions	Unit	289x780x215			289x900x215		298x900x215		290x1,050x250			
Weight	Unit	8			11		11		12			
Air filter	Type	Removable / washable / mildew proof										
Fan - Air flow rate	Cooling	High/Nom./Low/Silent operation	m ³ /min	7.9/6.3/4.7/3.9	9.2/7.2/5.2/3.9	8.8/6.7/4.7/3.9	9.1/7.0/5.0/3.9	11.2/8.5/5.8/4.1	11.2/11.2/7.0/4.1	11.9/11.9/7.4/4.5	16.0/16.0/11.3/10.1	17.2/17.2/11.5/10.5
	Heating	High/Nom./Low/Silent operation	m ³ /min	9.0/7.5/6.0/4.3	10.1/8.1/6.3/4.3	9.5/7.8/6.0/4.3	10.0/8.0/6.0/4.3	12.1/9.3/6.5/4.2	12.4/10.0/7.8/5.2	13.3/10.8/8.4/5.5	17.2/14.9/12.6/11.3	19.5/16.7/14.2/12.6
Sound power level	Cooling		dBA	55	59	58		59		60		63
	Heating		dBA	56		58		59		60	59	62
Sound pressure level	Cooling	High/Nom./Low/Silent operation	dBA	37/31/25/21	42/35/28/21	40/32/24/19	41/33/25/19	45/37/29/19	45/39/33/21	46/40/34/23	45/41/36/33	46/42/37/34
	Heating	High/Nom./Low/Silent operation	dBA	38/33/28/21	41/36/30/21	40/34/27/19	41/34/27/19	45/39/29/19	45/39/33/22	47/40/34/24	44/40/35/32	46/42/37/34
Power supply	Phase / Frequency / Voltage	Hz / V 1~ / 50 / 220-240										
Control systems	Infrared remote control	ARC466A6							ARC452A3			

CTXS15K / FTXS20-25K

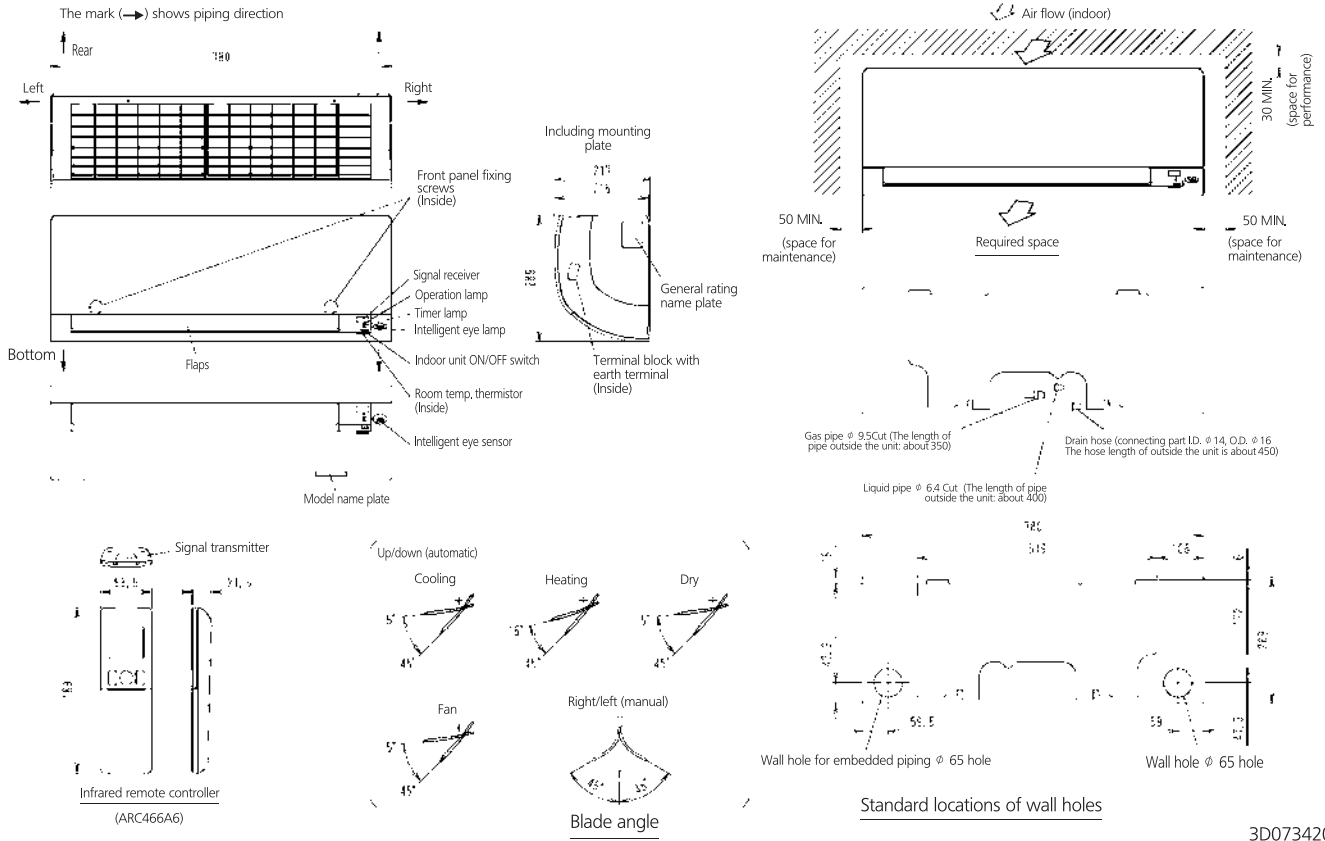

3D073420A

Indoor Units

FTXS35-42K / CTXS35K

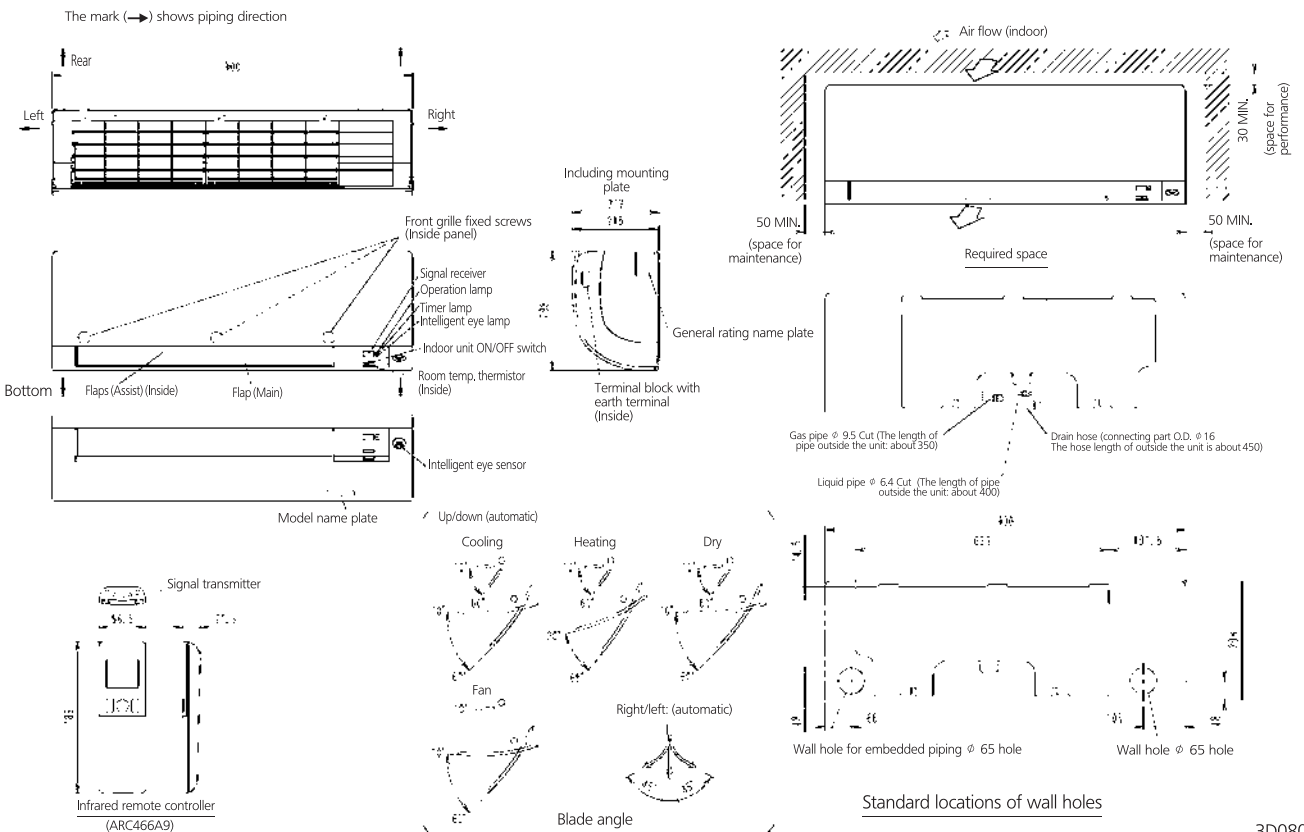

3D080105A

FTXS50K

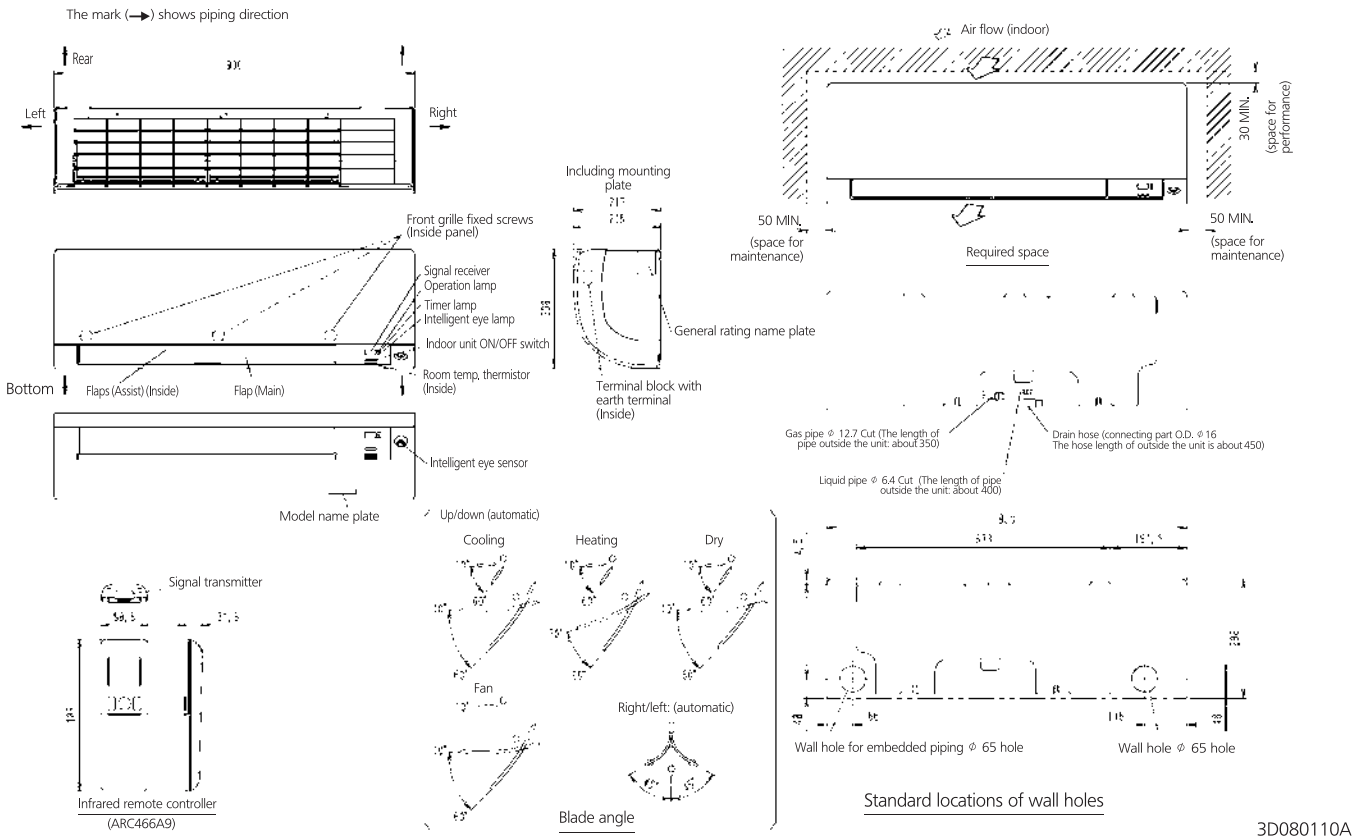

FTXS60G

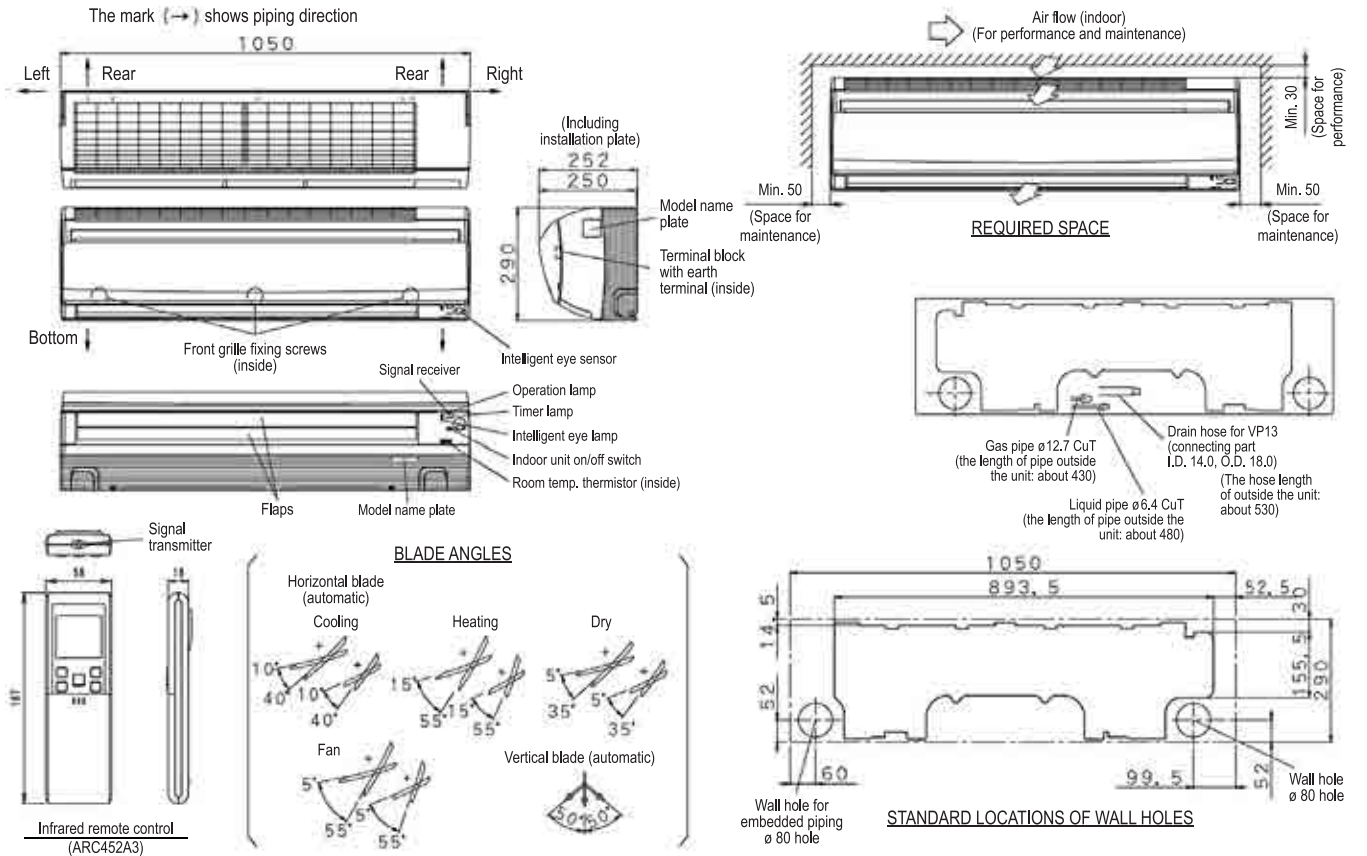

FTXS71G

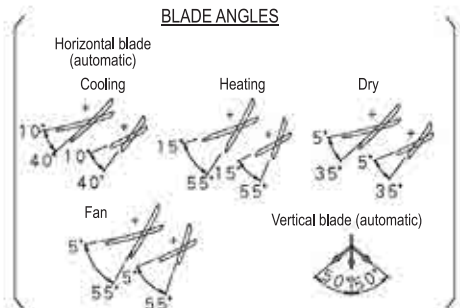
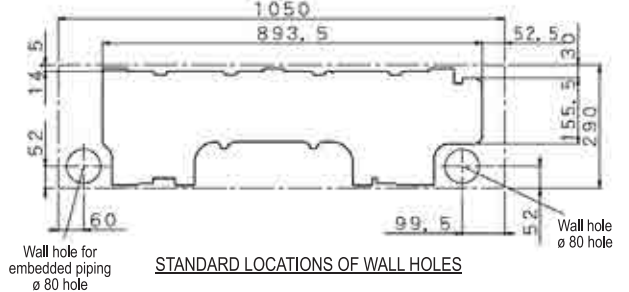
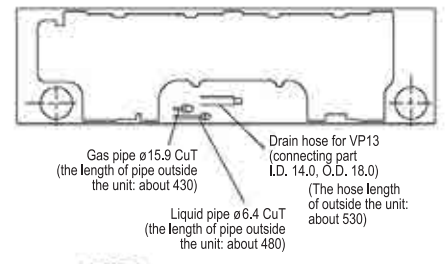
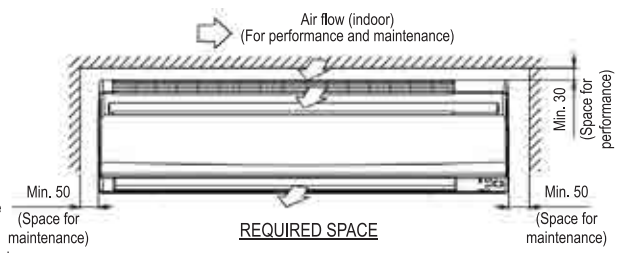
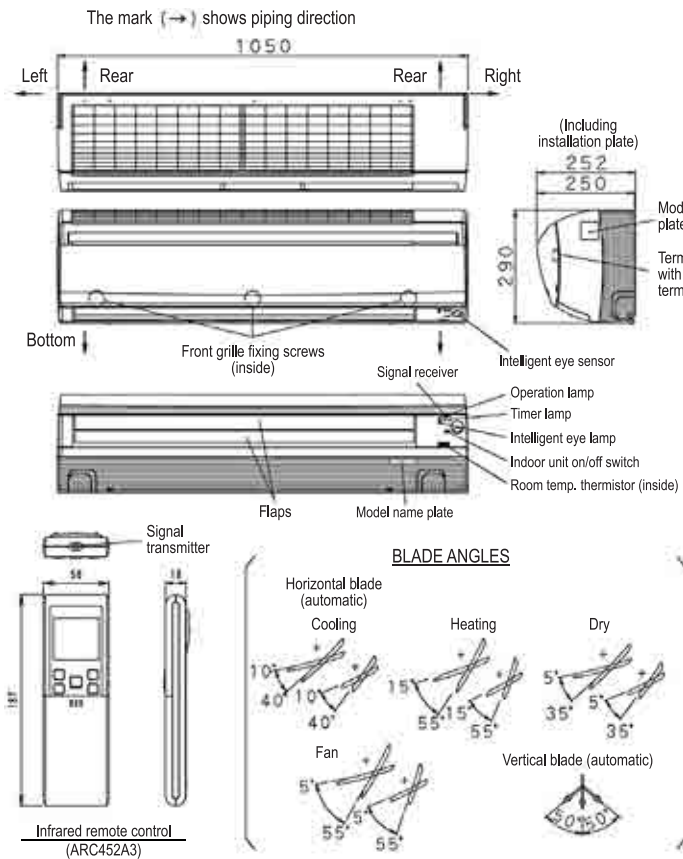

Indoor Units

3D065515

The best of two worlds united

Pure comfort and design



Why choose Nexura?

- Unique radiant heat panel that heats up just like a traditional radiator
- Whisper quiet operation down to 19 dBA
- Unobtrusive yet stylish design
- Reduced air flow, creating an even distribution of air through the room

Comfort is key

Nexura makes your world a comfortable one. The coolness of a summer breeze or the cosiness of an extra heat source brings a feeling of well-being to your space all year round. Its unobtrusive yet stylish design with a front panel that radiates additional heat, its low noise level and reduced air flow turn your room into a haven.

Radiant heat panel

To add even more comfort on cold days, the aluminium front panel of the Nexura unit has the capability of warming up, just like a traditional radiator. The result? A comfortable feeling of warm air that envelopes you. And all you have to do to activate this unique feature is push the "radiant" button on your remote control.

Online controller

Always in control, no matter where you are.

Benefits

- > Vertical autoswing
- > Weekly timer

Control your indoor from any location with an app, via your local network or internet.



Floor standing unit with radiant heat panel

Stylish floor standing unit with radiant heat panel for comfortable heat and very low noise

- › The aluminium part of the front panel of the Nexura indoor unit has the capability of warming up, just like a traditional radiator, to add even more comfort on cold days
- › Quiet and discrete, Nexura offers you the best in heating and cooling, in comfort and design
- › The indoor unit distributes air at the sound of a whisper. The noise produced amounts to barely 22dB(A) in cooling and 19dB(A) in radiant heat mode. In comparison, the ambient sound in a quiet room amounts to 40dB(A) on average.
- › Comfortable vertical auto swing ensures draughtfree operation and prevents ceiling soiling
- › Online controller (optional): control your indoor from any location with an app, via your local network or internet
- › Can be installed against a wall or recessed



Indoor unit	FVXG	25K	35K	50K
Casing	Colour	Fresh white (6.5Y 9.5/0.5)		
Dimensions	Unit	600x950x215		
Weight	Unit	22		
Air filter	Type	Removable / washable / mildew proof		
Fan - Air flow rate	Cooling	High/Nom./Low/Silent operation	8.9/8.9/5.3/4.5	9.1/9.1/5.3/4.5
	Heating	High/Nom./Low/Silent operation	9.9/7.8/5.7/4.7	10.2/8.0/5.8/5.0
Sound power level	Cooling		52	58
	Heating		53	60
Sound pressure level	Cooling	High/Nom./Low/Silent operation	38/32/26/23	39/33/27/24
	Heating	High/Nom./Low/Silent operation/Radiant heat	39/32/26/22/19	40/33/27/23/19
Power supply	Phase / Frequency / Voltage	1~ / 50 / 220-240		
Control systems	Infrared remote control	ARC466A2		

(1) EER/COP according to Eurovent 2012, for use outside EU only (2) Nominal efficiency: cooling at 35°/27° nominal load, heating at 7°/20° nominal load

FVXG25-35K

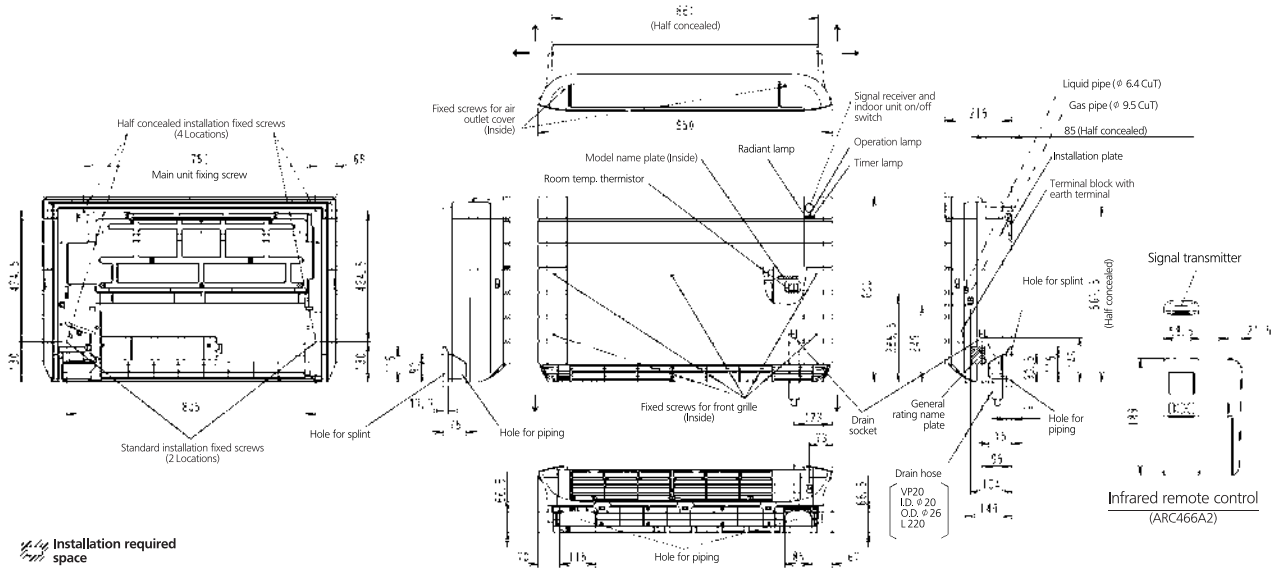

Installation required space

Air flow (Indoor)

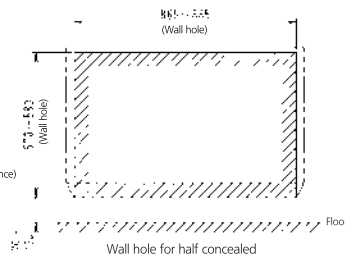
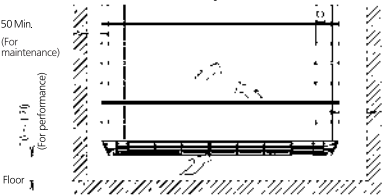

Adjusting the air flow direction

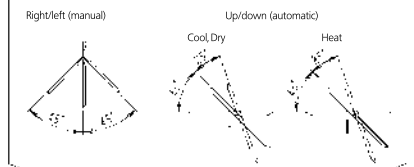

Note) The mark (→) shows piping direction

3D071595

FVXG50K

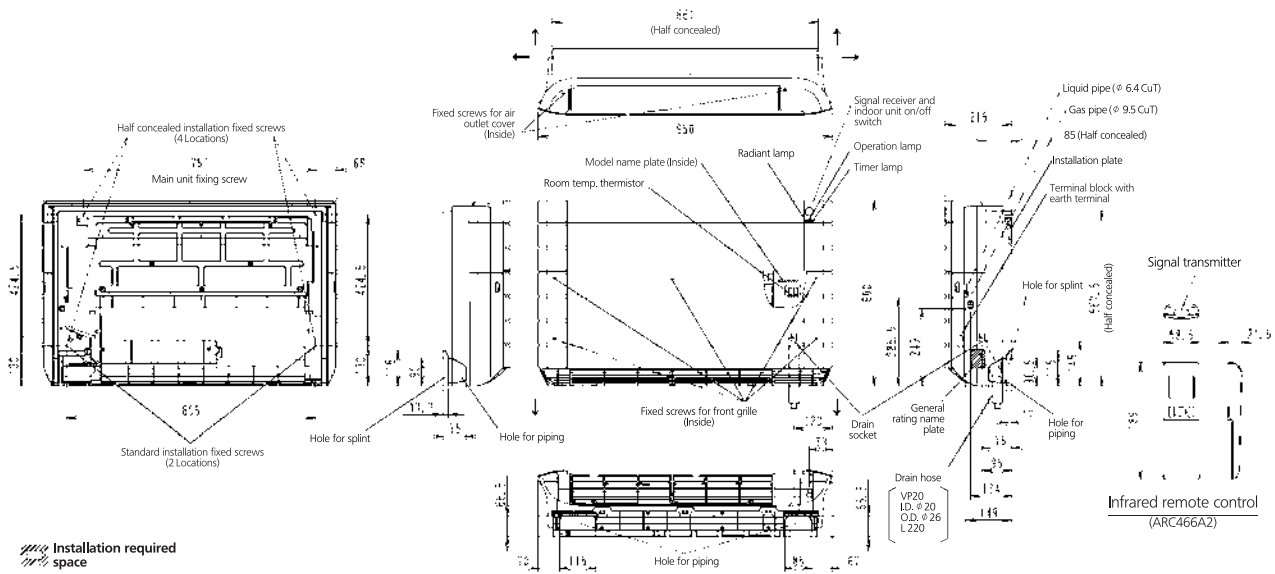

Installation required space

Air flow (Indoor)

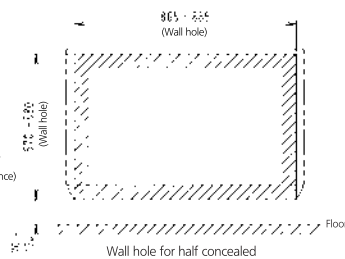
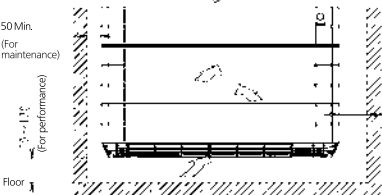

Adjusting the air flow direction

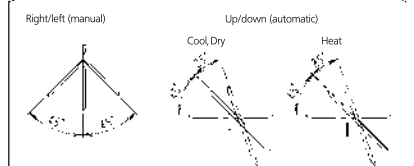

Note) The mark (→) shows piping direction

3D071596

Floor standing unit

Floor standing unit for optimal heating comfort thanks to dual airflow

- › Its low height enables the unit to fit perfectly beneath a window
- › Can be installed against a wall or recessed
- › Vertical auto swing moves the discharge flaps up and down for efficient air and temperature distribution throughout the room
- › Online controller (optional): control your indoor from any location with an app, via your local network or internet

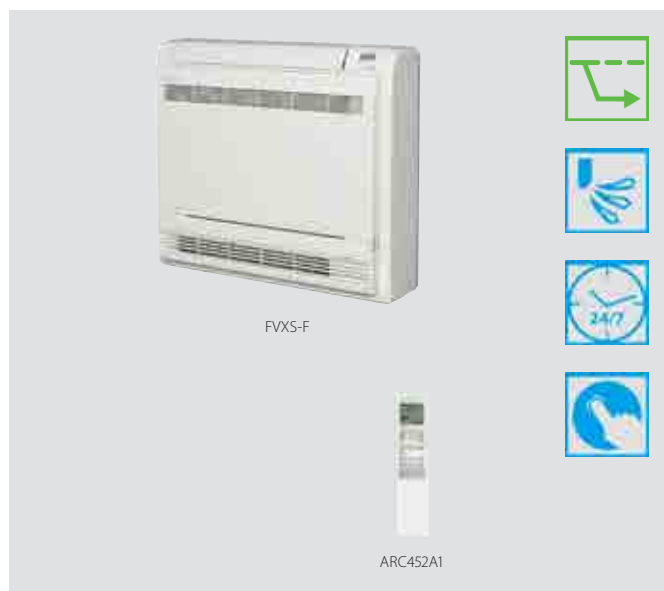

Indoor unit		FVXS	25F	35F	50F	
Casing	Colour			White		
Dimensions	Unit	HeightxWidthxDepth	mm			
			600x700x210			
Weight	Unit		kg			
			14			
Air filter	Type		Removable / washable / mildew proof			
Fan - Air flow rate	Cooling	High/Nom./Low/Silent operation	m ³ /min	8.2/8.2/4.8/4.1	8.5/8.5/4.9/4.5	10.7/10.7/7.8/6.6
	Heating	High/Nom./Low/Silent operation	m ³ /min	8.8/6.9/5.0/4.4	9.4/7.3/5.2/4.7	11.8/10.1/8.5/7.1
Sound power level	Cooling			52		
	Heating			52		
Sound pressure level	Cooling	High/Nom./Low/Silent operation	dBA	38/32/26/23	39/33/27/24	44/40/36/32
	Heating	High/Nom./Low/Silent operation	dBA	38/32/26/23	39/33/27/24	45/40/36/32
Power supply	Phase / Frequency / Voltage		Hz / V			
			1~ / 50 / 220-240			
Control systems	Infrared remote control		ARC452A1			

(1) EER/COP according to Eurovent 2012, for use outside EU only (2) Nominal efficiency: cooling at 35°/27° nominal load, heating at 7°/20° nominal load

Flexi type unit

Flexible unit, ideal for rooms without false ceiling, can fit on either ceiling or wall

- › Can fit on either ceiling or lower wall; its low height enables the unit to fit beneath a window
- › Vertical auto swing moves the discharge flaps up and down for efficient air and temperature distribution throughout the room
- › Home leave operation maintains the indoor temperature at your specified comfort level during absence, thus saving energy
- › Online controller (optional): control your indoor unit from any location via smartphone, laptop, pc, tablet or touch screen



Indoor unit		FLXS	25B	35B9	50B	60B	
Casing	Colour		Almond white			Almond white	
Dimensions	Unit	HeightxWidthxDepth	490x1,050x200			490x1,050x200	
Weight	Unit	kg	16		17		
Air filter	Type		Removable / washable / mildew proof				
Fan - Air flow rate	Cooling	High/Nom./Low/Silent operation	m ³ /min	7.6/7.6/6.0/5.2	8.6/7.6/6.6/5.6	11.4/11.4/8.5/7.5	12.0/10.7/9.3/8.3
	Heating	High/Nom./Low/Silent operation	m ³ /min	9.2/8.3/7.4/6.6	12.8/10.4/8.0/7.2	12.1/9.8/7.5/6.8	12.8/10.6/8.4/7.5
Sound power level	Cooling		dBA	51	53	60	
	Heating		dBA	51	59	-	59
Sound pressure level	Cooling	High/Nom./Low/Silent operation	dBA	37/34/31/28	38/35/32/29	47/43/39/36	48/45/41/39
	Heating	High/Nom./Low/Silent operation	dBA	37/34/31/29	46/36/33/30	46/41/35/33	47/42/37/34
Power supply	Phase / Frequency / Voltage	Hz / V	1~ / 50/60 / 220-240/220-230	1~ / 50 / 220-240	1~ / 50/60 / 220-240/220-230		
Control systems	Infrared remote control		ARC433B67				

(1) EER/COP according to Eurovent 2012, for use outside EU only (2) Nominal efficiency; cooling at 35°/27° nominal load, heating at 7°/20° nominal load

FLXS25-35B(9)

Ceiling suspended installation

The mark (→) shows piping direction

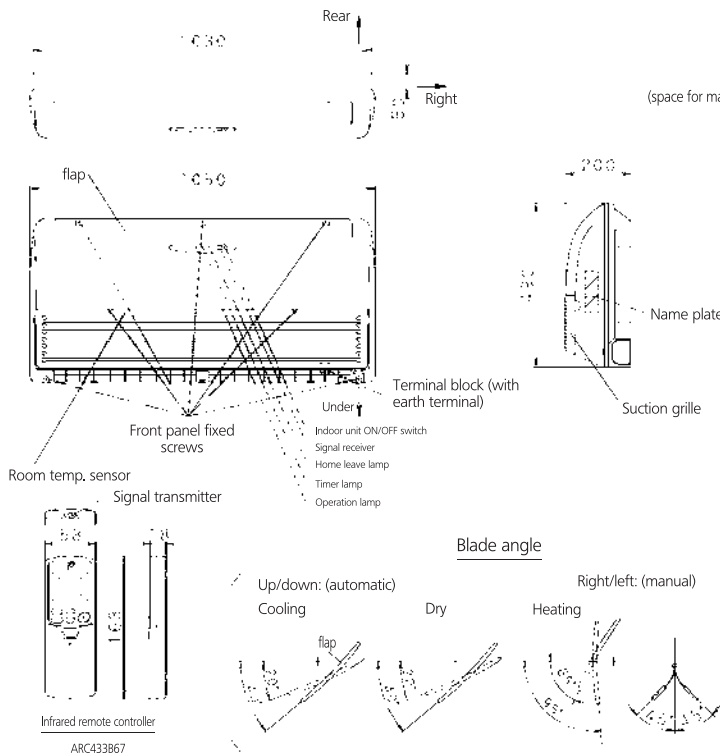

Required space (Ceiling suspended)
(for performance and maintenance)

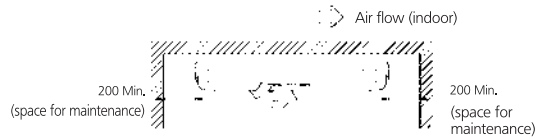

- Liquid pipe (6.4 CuT)
- Gas pipe (φ 9.5 CuT)

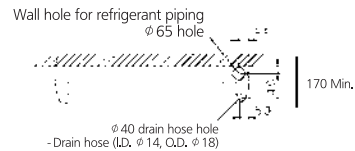

Standard locations of wall holes

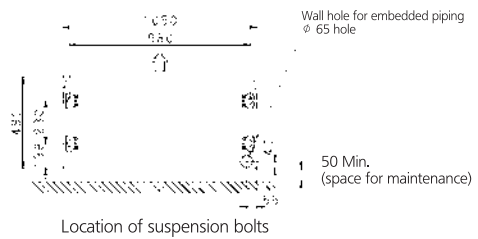

3D033694G

FLXS50-60B

Ceiling suspended installation

The mark (→) shows piping direction

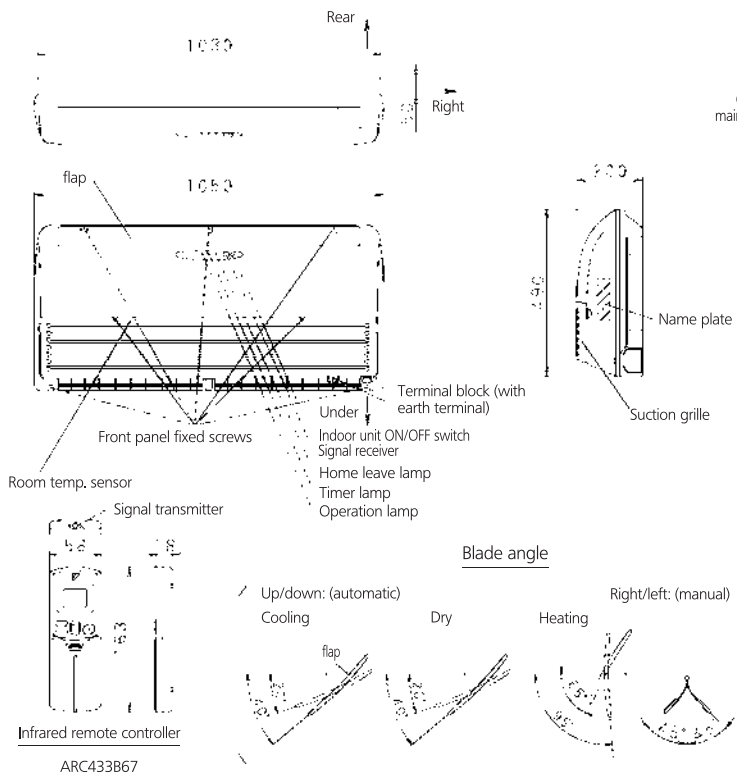

Required space (Ceiling suspended)
(for performance and maintenance)

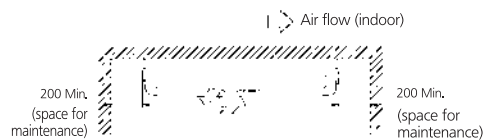

- Liquid pipe (φ 6.4CuT)
- Gas pipe (φ 12.7 CuT)

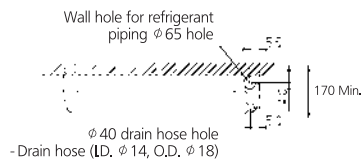

Standard locations of wall holes

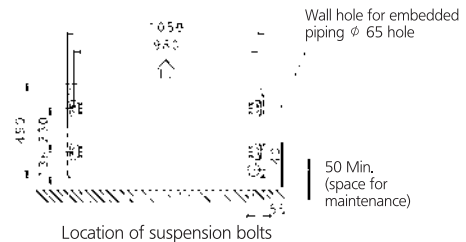

3D050610B

FLXS25-35B(9)

Floor level installation

The mark (→) shows piping direction

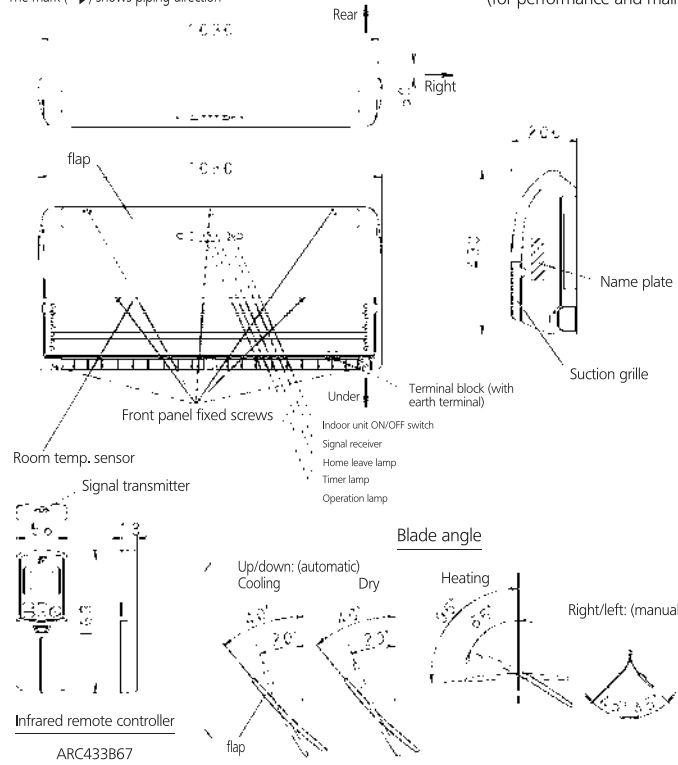

Required space (for performance and maintenance)

↗ Air flow (indoor)

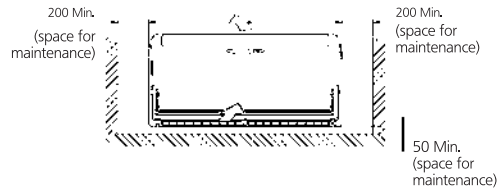

- Liquid pipe (φ 6.4 CuT)
- Gas pipe (φ 9.5 CuT)
- Drain hose (I.D. φ 14, O.D. φ 18)

Wall hole for refrigerant piping φ 80 hole

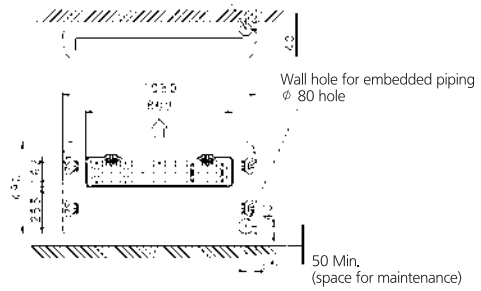

Standard locations of wall holes

3D033695H

Indoor Units

FLXS50-60B

Floor level installation

The mark (→) shows piping direction

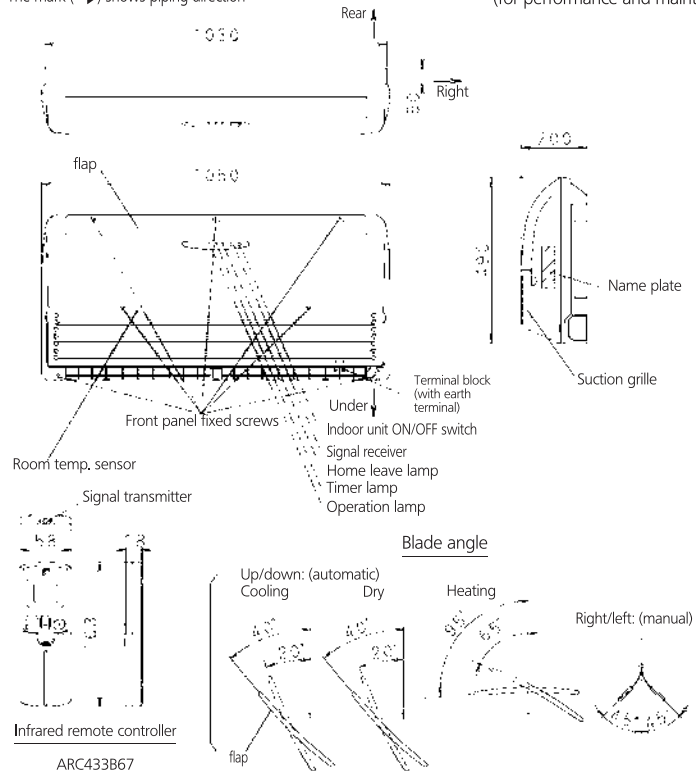

Required space (for performance and maintenance)

↗ Air flow (indoor)

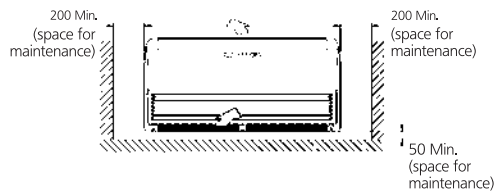

- Liquid pipe (φ 6.4 CuT)
- Gas pipe (φ 12.7 CuT)
- Drain hose (I.D. φ 14, O.D. φ 18)

Wall hole for refrigerant piping φ 80 hole

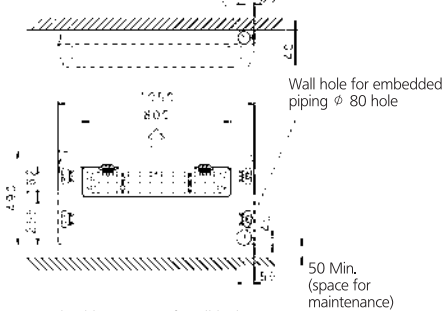

Standard locations of wall holes

3D050615B

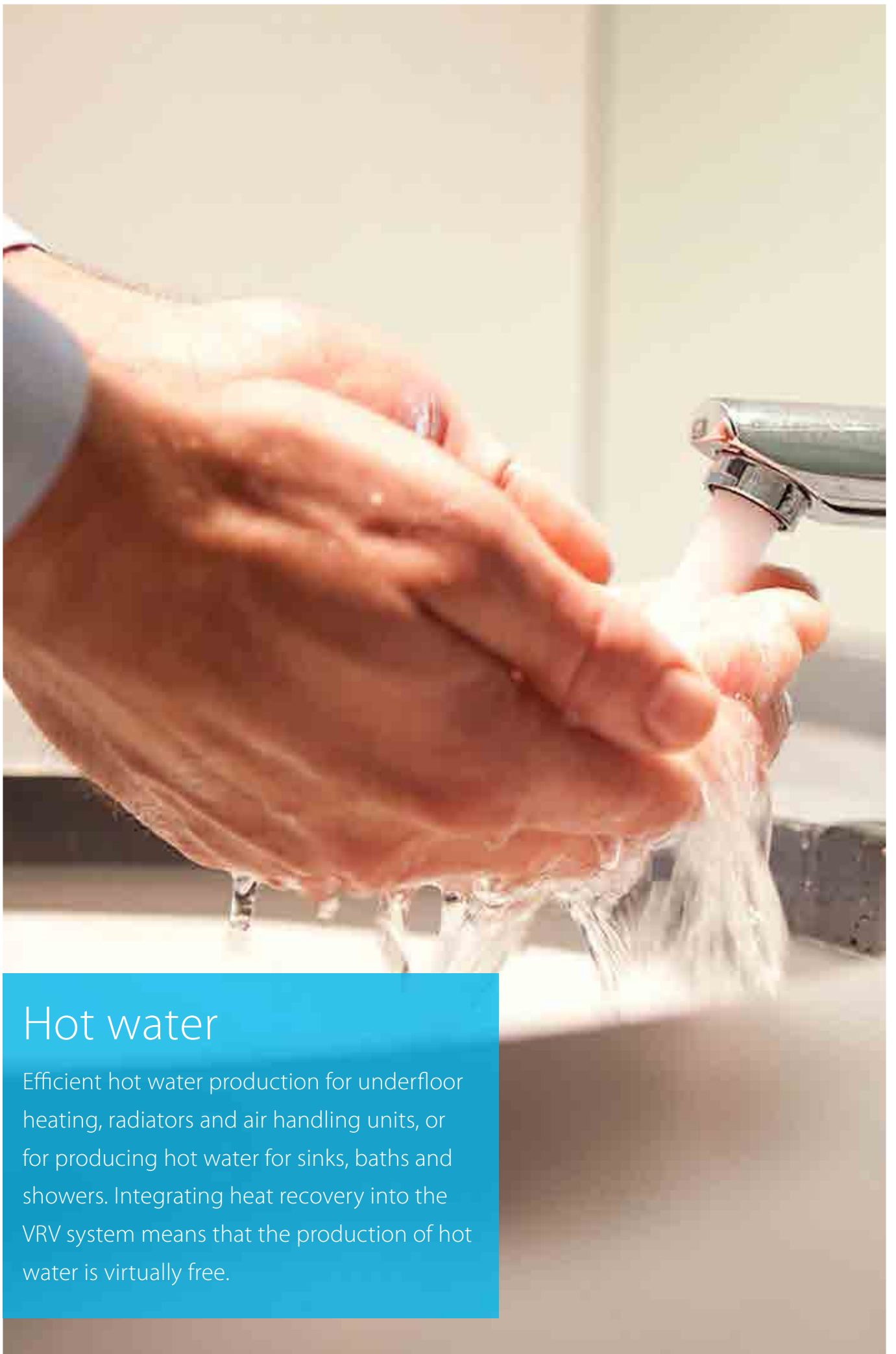

Hot water

Efficient hot water production for underfloor heating, radiators and air handling units, or for producing hot water for sinks, baths and showers. Integrating heat recovery into the VRV system means that the production of hot water is virtually free.

Hot water

Low temperature hydrobox HXY-A	168
High temperature hydrobox HXHD-A	170
Accessories for hot water	173

Low temperature hydrobox for VRV

For high efficiency space heating and cooling

- › Air to water connection to VRV for applications such as underfloor, air handling units, low temperature radiators, ...
- › Leaving water temperature range from 5°C to 45°C without electric heater
- › Super wide operating range for hot/cold water production from -20 to +43°C ambient outdoor temperature
- › Saves time on system design as all water-side components are fully integrated with direct control over leaving water temperature
- › Space saving contemporary wall hung design
- › No gas connection or oil tank needed
- › Connectable to VRV IV heat pump and heat recovery

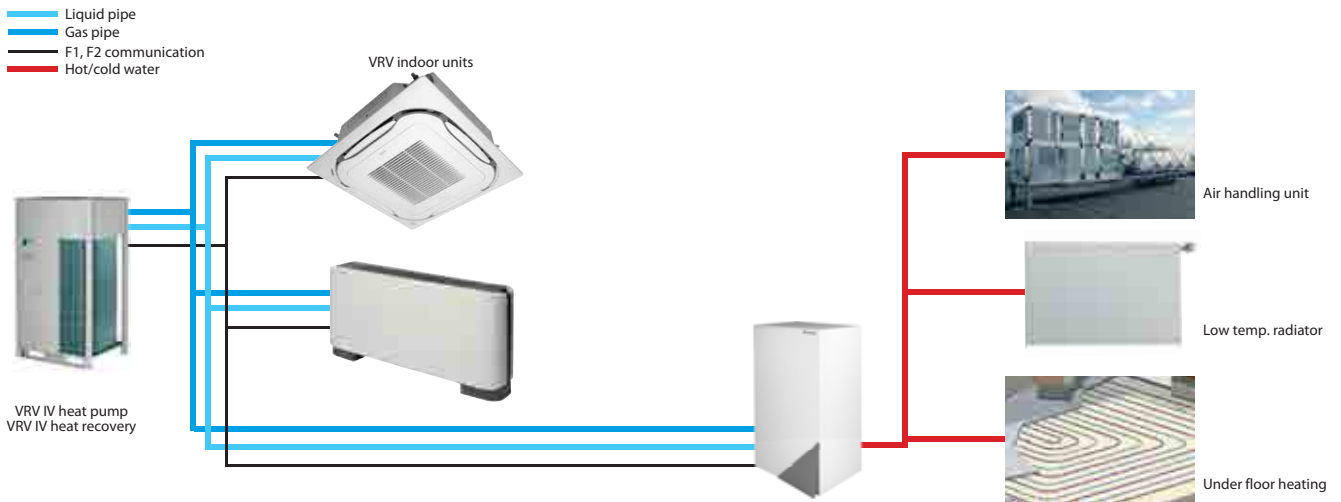

Indoor unit		HXY	080A	125A
Cooling capacity	Nom.	kW	8.0	12.5
Heating capacity	Nom.	kW	9.0	14.0
Dimensions	Unit	HeightxWidthxDepth	890x480x344	
Weight	Unit	kg	44	
Casing	Colour		White	
	Material		Precoated sheet metal	
Sound pressure level	Nom.	dB(A)	-	
Operation range	Heating	Ambient	-20~24 °C	
		Water side	25~45 °C	
Refrigerant	Type / GWP		R-410A / 2.087,5	
Refrigerant circuit	Gas side diameter	mm	15.9	
	Liquid side diameter	mm	9.5	
Water circuit	Piping connections diameter	inch	G 1"1/4 (female)	
Power supply	Phase/Frequency/Voltage	Hz/V	1~/50/220-240	
Current	Recommended fuses	A	6~16	

HXY-A

Required space for service and ventilation

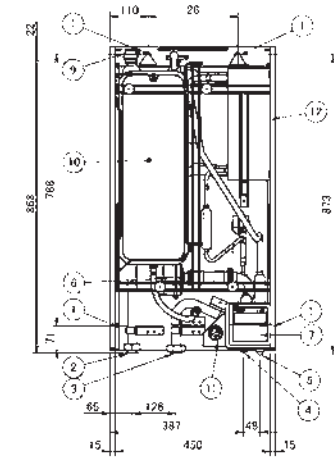
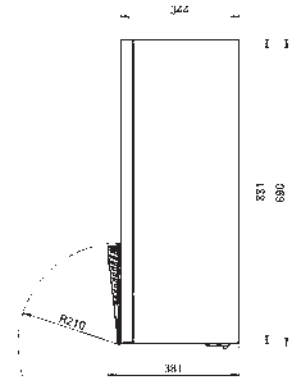
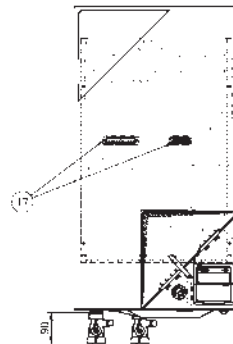
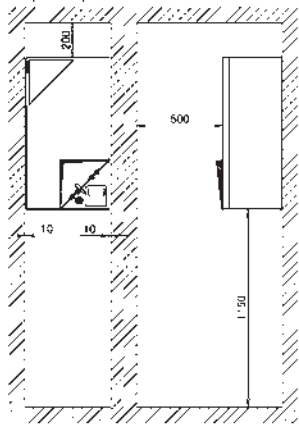

- 1 Holes (Ø12) for fixation to the wall
- 2 Water out connection (1-1/4" F BSP)
- 3 Water in connection (1-1/4" F BSP)
- 4 Refrigerant liquid connection Ø9.52 (flare)
- 5 Refrigerant suction connection Ø15.9 (flare)
- 6 Pump
- 7 User interface
- 8 Safety valve (pressure)
- 9 Air purge
- 10 Expansion vessel
- 11 Pressure gauge
- 12 Heat exchanger (refrigerant / water)
- 13 Shut off valve with drain / fill valve (1-1/4" F BSP) (included accessory)
- 14 Water filter
- 15 Power supply / Communication wire entrance
- 16 Service door
- 17 Switchbox terminals

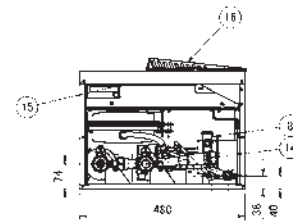

HXY-A

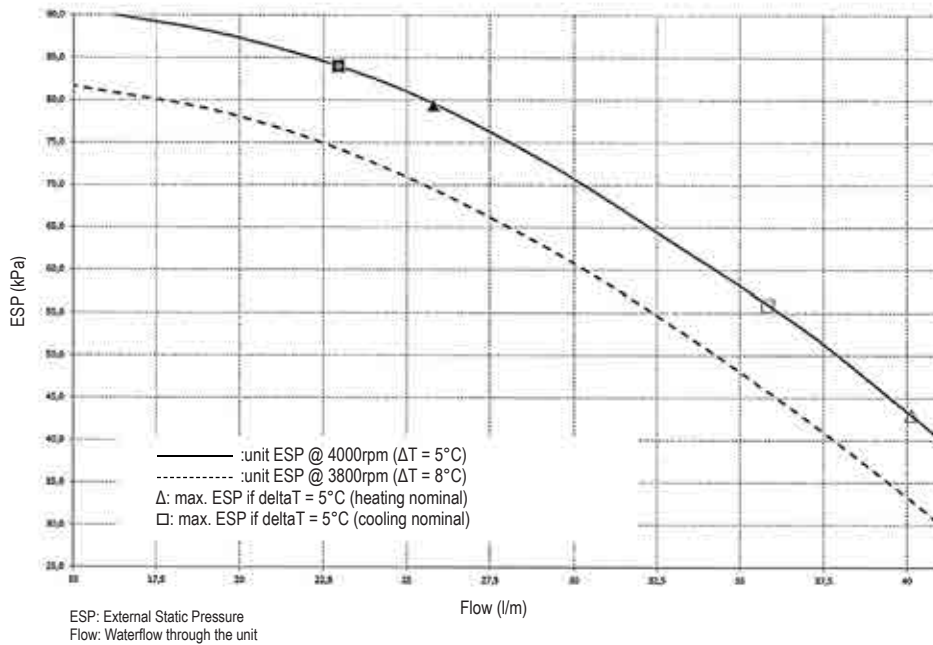

NOTES

- 1 Selecting a flow outside the curves can cause damage to or malfunctioning of the unit. See also minimum and maximum allowed flow in technical specifications.
- 2 Water quality must be according to EN directive EC 98/83 EC.

High temperature hydrobox for VRV

For efficient hot water production and space heating

- › Air to water connection to VRV for applications such as bathrooms, sinks, underfloor heating, radiators and air handling units
- › Leaving water temperature range from 25 to 80°C without electric heater
- › Free heating provided by transferring heat from areas requiring cooling to areas requiring heating or hot water
- › Uses heat pump technology to produce hot water efficiently, providing up to 17% savings compared to a gas boiler
- › Possibility to connect thermal solar collectors to the domestic hot water tank
- › Super wide operating range for hot water production from -20 to +43°C ambient outdoor temperature
- › Saves time on system design as all water-side components are fully integrated with direct control over leaving water temperature
- › Various control possibilities with weather dependant set point or thermostat control
- › The indoor unit and domestic hot water tank can be stacked to save space, or installed next to each other, if only limited height is available
- › No gas connection or oil tank needed
- › Connectable to VRV IV heat recovery

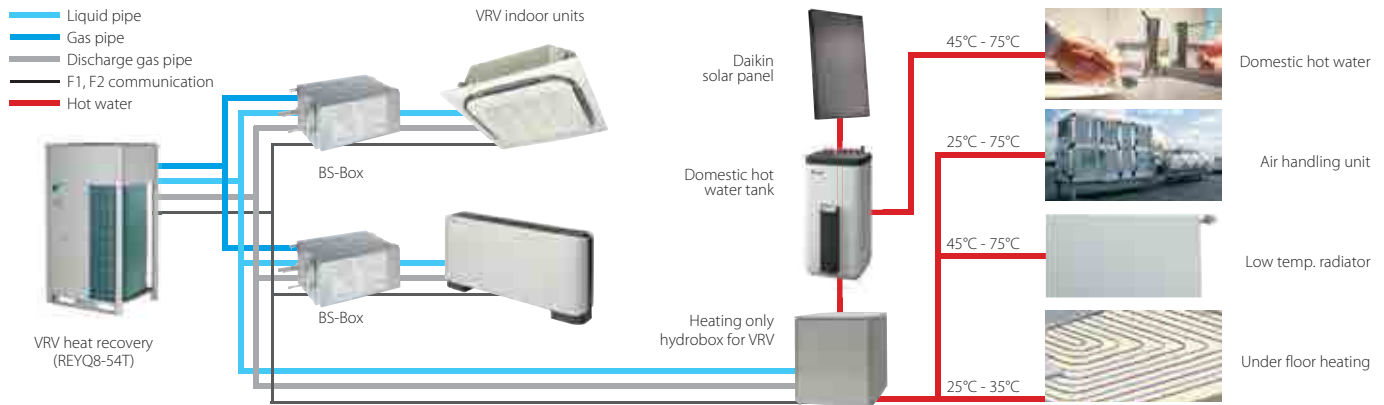

Indoor unit		HXHD		125A
Heating capacity	Nom.			kW
				14.0
Dimensions	Unit	HeightxWidthxDepth		mm
				705x600x695
Weight	Unit			kg
				92
Casing	Colour			
	Material			Metallic grey
				Precoated sheet metal
Sound pressure level	Nom.			dB(A)
	Night quiet mode	Level 1		dB(A)
				42 (1) / 43 (2)
				38
Operation range	Heating	Ambient	Min.~Max.	°C
		Water side	Min.~Max.	°C
				-20~-20 / 24 (3)
	Domestic hot water	Ambient	Min.~Max.	°C
		Water side	Min.~Max.	°C
				25~80
				-20~43
				45~75
Refrigerant	Type / GWP			
	Charge			kg
	Charge		TCO,Eq	
				R-134a / 1,430
				2
				2.9
Refrigerant circuit	Gas side diameter			mm
	Liquid side diameter			mm
				12.7
				9.52
Water circuit	Piping connections diameter			inch
	Heating water system	Water volume	Min.~Max.	
				I
				G 1" (female)
				20~200
Power supply	Phase/Frequency/Voltage			Hz/V
				1~/50/220-240
Current	Recommended fuses			A
				20

(1) Sound levels are measured at: EW 55°C; LW 65°C (2) Sound levels are measured at: EW 70°C; LW 80°C (3) Field setting

HXHD-A

Detail A
Scale 1/3

If required (e.g. Wall fixation)
Pressure gauge can be removed from waterfilter, maximum distance
between waterfilter and pressure gauge ± 600 mm

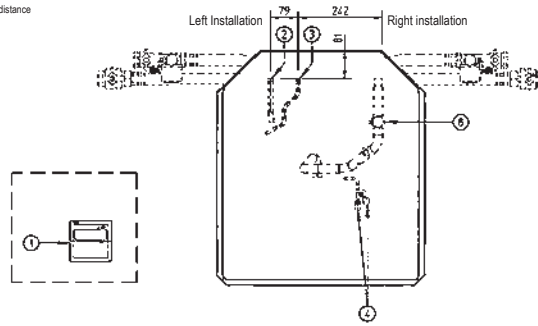
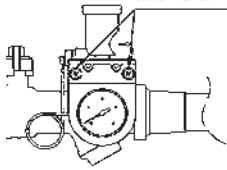

1	Remote control (delivered as accessory) Installation location is outside the unit
2	Discharge pipe connection $\phi 12.7$ solder (R410a)
3	Liquid pipe connection $\phi 9.5$ solder (R410a)
4	R134a Service ports 5/16" flare (2x)
5	Pressure gauge
6	Blow off valve
7	Drain valve water circuit
8	Air purge
9	Shut-off valves (2x)
10	Water filter
11	Water in connection G 1" (female)
12	Water out connection G 1" (female)
13	Control wiring intake (knock-out hole $\phi 37$)
14	Power supply wiring intake (knock-out hole $\phi 37$)
15	Knock-out holes for refrigerant piping and water piping
16	Levelling feet
17	Discharge stop valve $\phi 12.7$ solder (R410a)
18	Liquid stop valve $\phi 9.5$ solder (R410a)

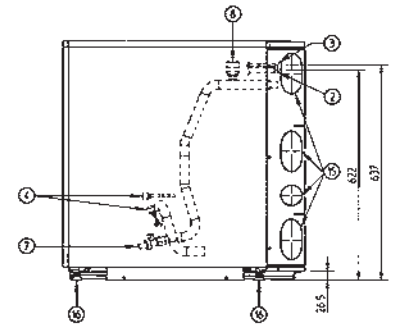
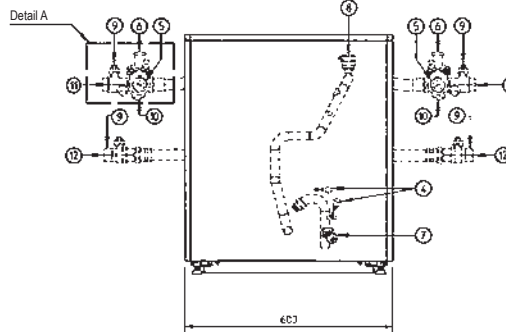
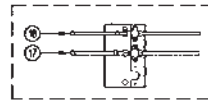
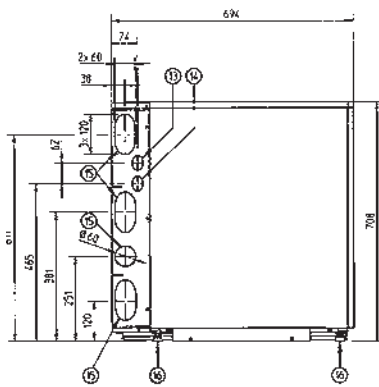

HXHD-A

Left Installation

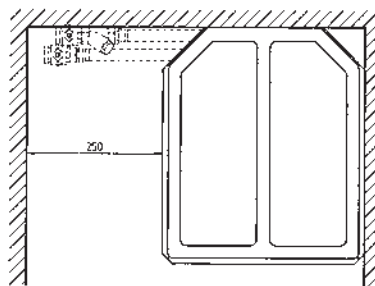

Right installation

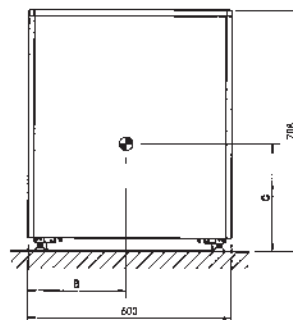
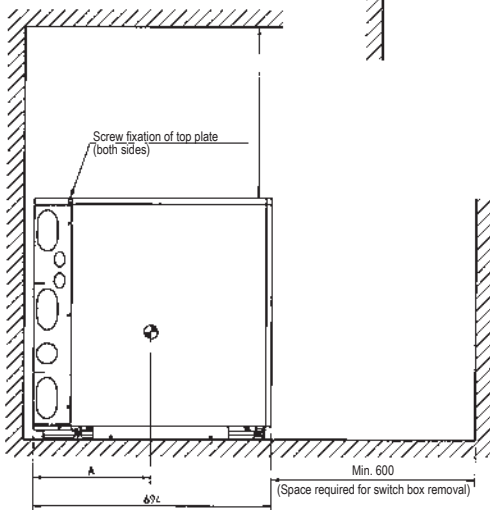
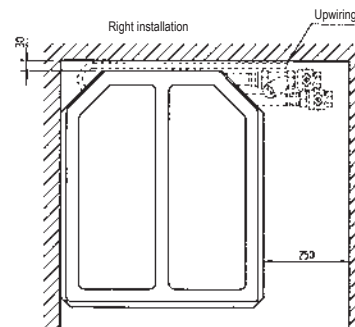

Model	A	B	C
HXHD-A	355	270	300

HXHD-A

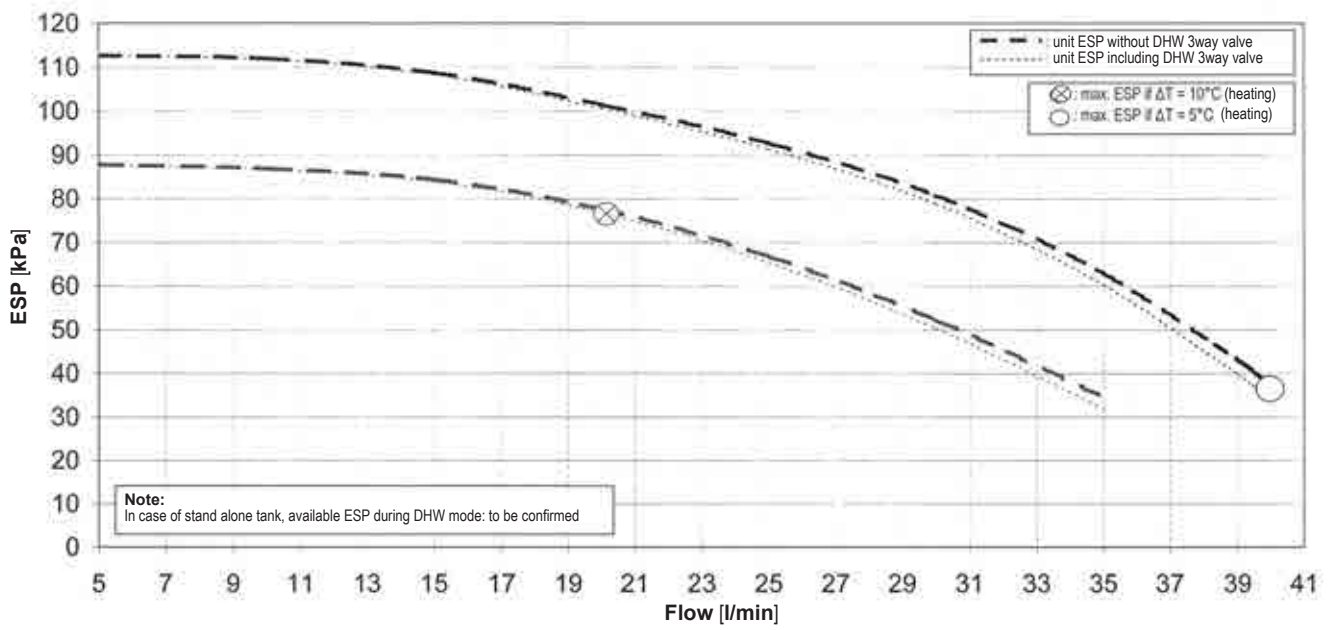

1. The ESP curves are the maximum ESP curve for different ΔT types (pump rpm = 4400 $\Delta T = 5^\circ\text{C}$; pump rpm = 4000 for $\Delta T = 10^\circ\text{C}$). The pump of the indoor module is inverter controlled and controls to have a fixed ΔT between return and leaving water temperature.
2. In case of installing a domestic hot water tank there is an additional pressure drop over the three way valve (delivered as accessory with the tank).

ESP: external static pressure
Flow: waterflow through the unit

Warning:

1. Selecting a flow outside the curve can cause damage to or malfunction of the unit. See also minimum and maximum allowed water flowrange in the technical specifications.
2. Water quality must be according to EN directive EC 98/83 EC.

Domestic hot water tank

Stackable stainless steel domestic hot water tank

- › The indoor unit and domestic hot water tank can be stacked to save space, or installed next to each other, if only limited height is available
- › Available in 200 and 260 liters
- › Heat loss is reduced to a minimum thanks to the high quality insulation
- › At necessary intervals, the indoor unit can heat up the water to 60°C to prevent the risk of bacteria growth
- › Efficient temperature heat-up: from 10°C to 50°C in only 60 minutes



Accessory		EKHTS			200AC	260AC
Casing	Colour	Metallic grey				
	Material	Galvanised steel (precoated sheet metal)				
Dimensions	Unit	Height	Integrated on indoor unit	mm	2,010	2,285
		Width				
	Depth	mm	695			
		mm				
Weight	Unit	Empty	kg	70	78	
	Tank	Water volume	l	200	260	
Heat exchanger	Material	Stainless steel (EN 1.4521)				
	Maximum water temperature	°C				
	Insulation	Heat loss	kWh/24h	1.2	1.5	
	Quantity	1				
	Tube material	Duplex steel (EN 1.4162)				
Heat exchanger	Face area	m²				
	Internal coil volume	l				
	Internal coil volume	l				
					1.56	7.5

EKHWP-B

Domestic hot water tank

Plastic domestic hot water tank with solar support

- › Available in 300 and 500 liters
- › Large hot water storage tank to provide domestic hot water at any time
- › Heat loss is reduced to a minimum thanks to the high quality insulation
- › Space heating support possible (500l tank only)



Accessory		EKHWP			300B	500B	
Dimensions	Unit	Width	mm	595	790		
		Depth	mm	615	790		
	Weight	Unit	Empty	kg	59	93	
Tank	Water volume	l					
	Maximum water temperature	°C					
	Insulation	Heat loss	kWh/24h	1.3	1.4		
Heat exchanger	Domestic hot water	Tube material	Stainless steel				
		Face area	m²	5.8	6		
		Internal coil volume	l	27.9	29		
	Operating pressure	bar	6				
	Average specific thermal output	W/K	2,790	2,900			
	Charging	Tube material	Stainless steel				
Face area		m²	2.7	3.8			
Internal coil volume		l	13.2	18.5			
Operating pressure		bar	3				
Average specific thermal output		W/K	1,300	1,800			
Auxiliary solar heating	Tube material	Stainless steel					
	Face area	m²	-	0.5			
	Internal coil volume	l	-	2.3			
	Operating pressure	bar	3				
	Average specific thermal output	W/K	-	280			

Pump station

- › Save energy and reduce CO₂ emissions with a solar system for domestic hot water production
- › Pump station connectable to unpressurised solar system
- › Pump station and control provide the transfer of solar heat to the domestic hot water tank



EKS RPS3

Accessory		EKS RPS	3
Mounting			On side of tank
Dimensions	Unit	HeightxWidthxDepth	mm
			815x230x142
Control	Type		Digital temperature difference controller with plain text display
	Power consumption	W	2
Power supply	Voltage	V	230
Sensor	Solar panel temperature sensor		Pt1000
	Storage tank sensor		PTC
	Return flow sensor		PTC
	Feed temperature and flow sensor		Voltage signal (3.5V DC)

EKS(H/V)-P

Solar collector

Thermal solar collector for hot water production

- › Solar collectors can produce up to 70% of the energy needed for hot water production - a major cost saving
- › Vertical or horizontal solar collector for domestic hot water production
- › High efficiency collectors transfer all the short-wave solar radiation into heat as a result of their highly selective coating
- › Easy to install on roof tiles

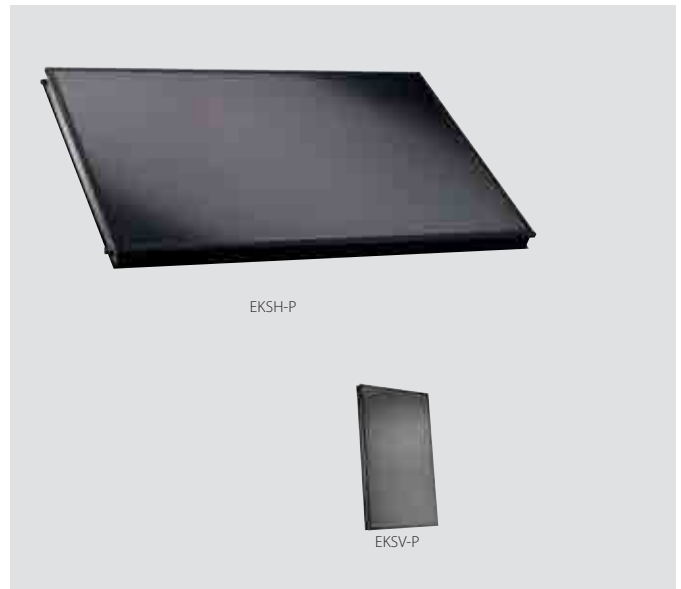

EKSH-P

EKSV-P

Accessory			EKSV21P	EKSV26P	EKSH26P	
Dimensions	Unit	HeightxWidthxDepth	mm	2,000x1,006x85	2,000x1,300x85	1,300x2,000x85
Weight	Unit		kg	35		42
Volume			l	1.3	1.7	2.1
Surface	Outer		m ²	2.01		2.6
	Aperture		m ²	1.79		2.35
	Absorber		m ²	1.8		2.36
Coating	Micro-therm (absorption max. 96%, Emission ca. 5% +/-2%)					
Absorber	Harp-shaped copper pipe register with laser-welded highly selective coated aluminium plate					
Glazing	Single pane safety glass, transmission +/- 92%					
Allowed roof angle	Min.-Max.		°	15~80		
Operating pressure	Max.		bar	6		
Stand still temperature	Max.		°C	200		

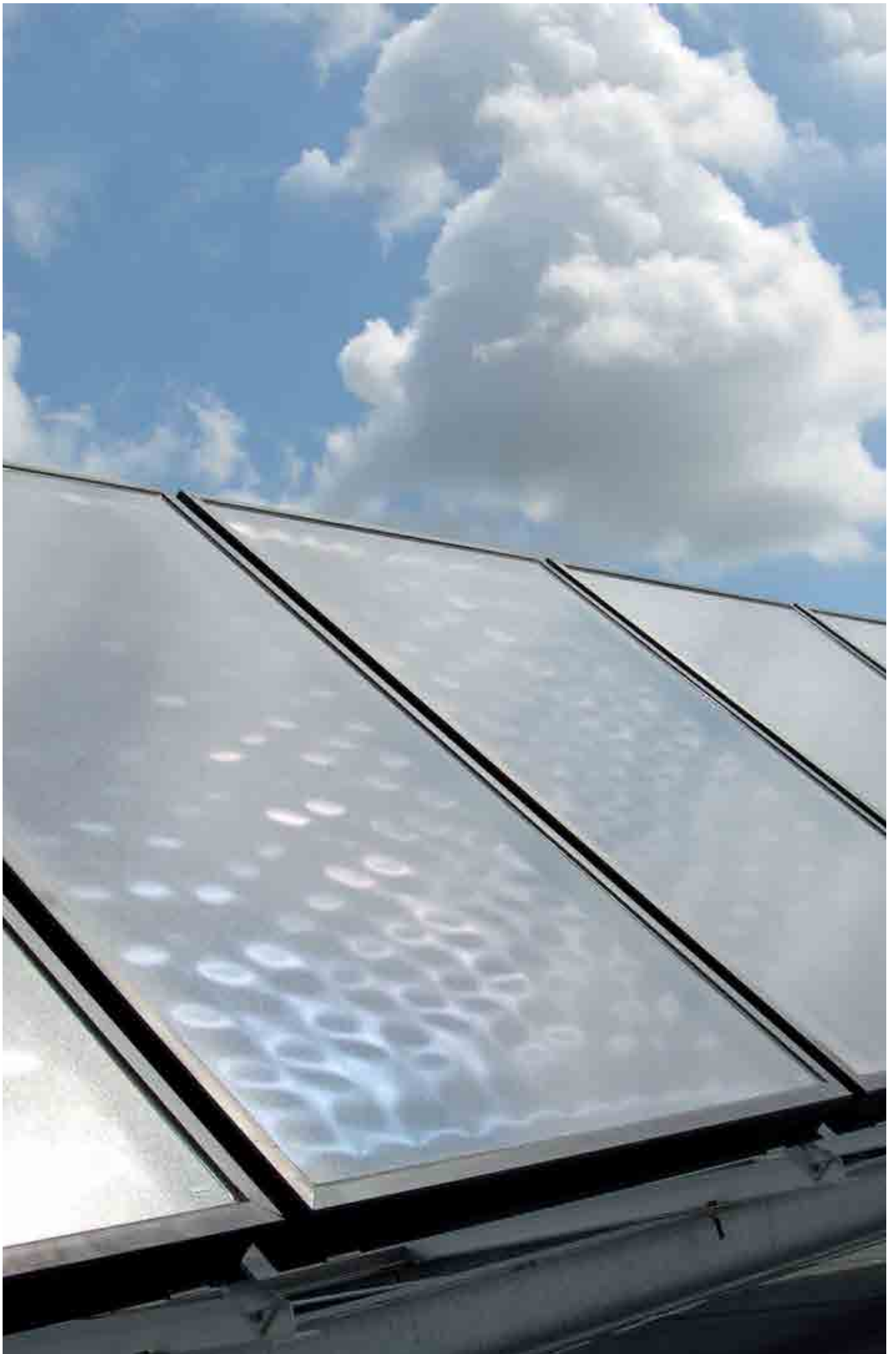

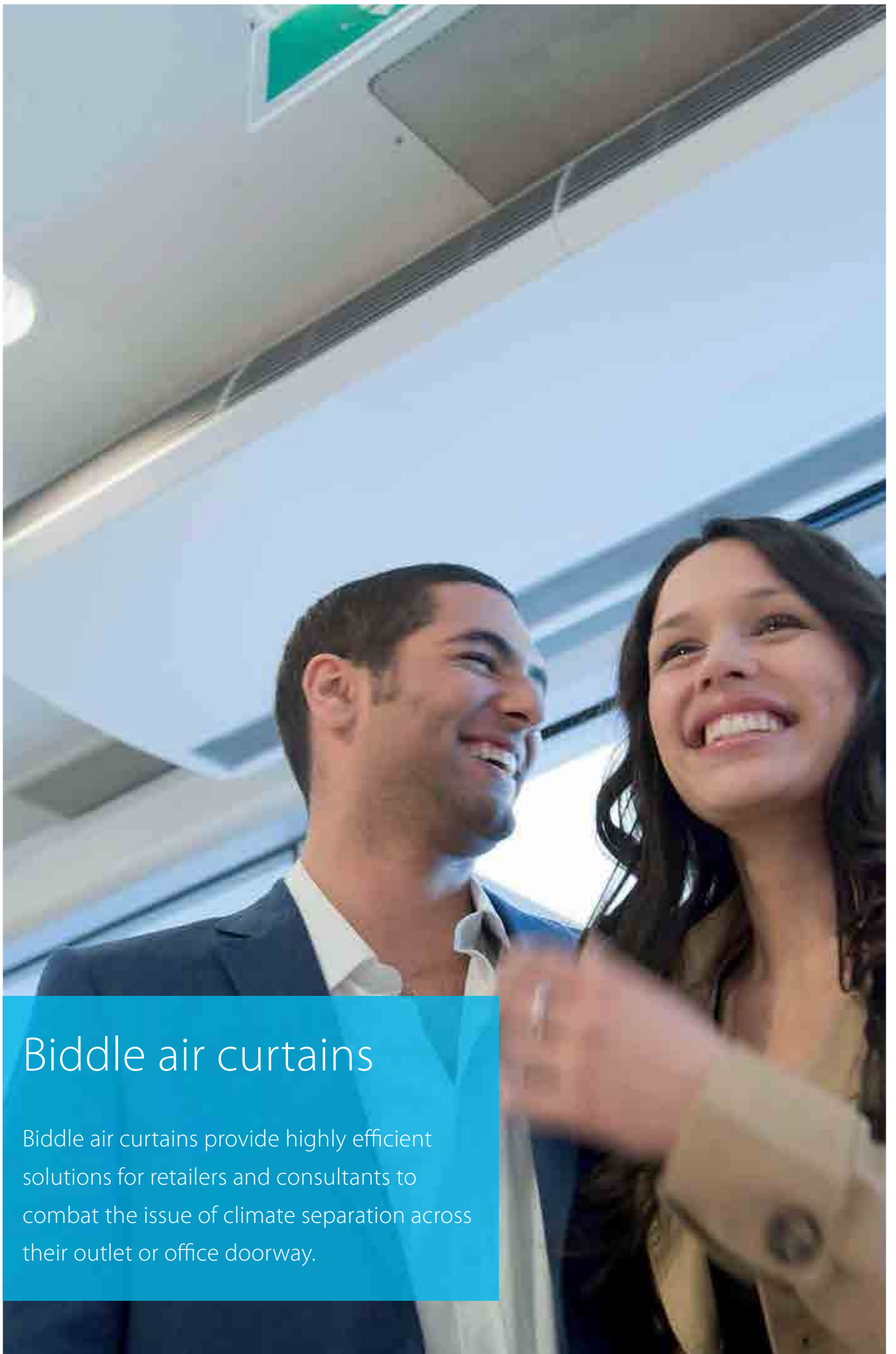

Biddle air curtains

Biddle air curtains provide highly efficient solutions for retailers and consultants to combat the issue of climate separation across their outlet or office doorway.

Biddle air curtains

connected to Daikin Heat Pumps

'Open Door' Trading

Although the customer friendly aspects of open door trading are widely appreciated by retail and commercial outlet managers, open doors can also give rise to massive losses in conditioned warm or cold air and hence, energy. Biddle air curtains however, not only preserve indoor temperatures and generate significant economies, they also represent an invitation for customers, to enter a pleasant trading and working environment.

High efficiency and low CO₂ emission

An efficient outdoor/indoor climate separation limits heat loss through the door opening and enhances the efficiency of the air conditioning system. Combining Biddle air curtains with Daikin heat pumps can lead to savings up to 72% compared to electric air curtains and a paypack period of less than 1.5 years!

Which air curtain offers me the best solution?

Biddle air curtains come in 2 versions, one to connect to VRV end one for connection to ERQ. Both of them are available in varying door widths from 1 up to

2.5 meters. Below you can find an overview of the different versions and available door heights.

Biddle air curtain for connection to VRV (CYV) or to ERQ (CYQ)



Biddle comfort air curtain range

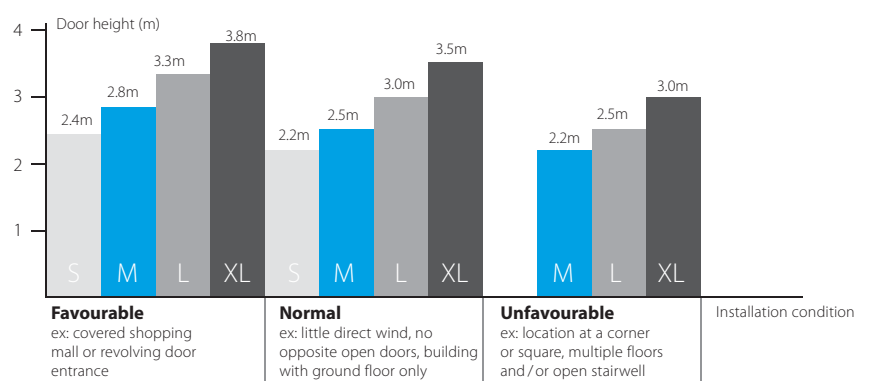

Biddle comfort air curtain nomenclature

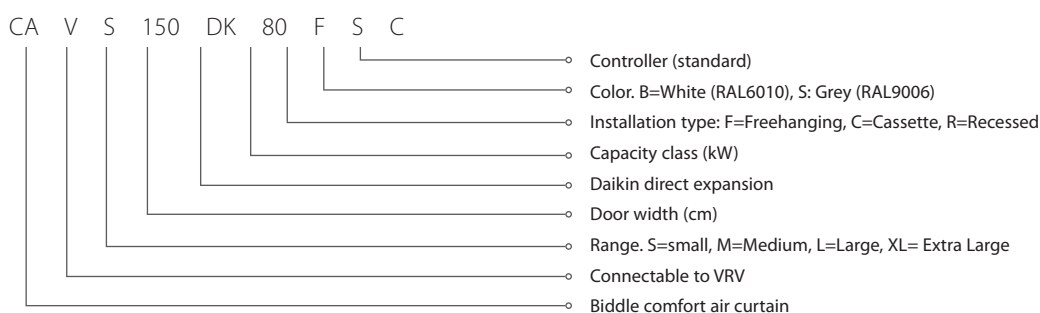

Biddle air curtain for VRV

- › Connectable to VRV heat recovery and heat pump
- › VRV is among the first DX systems suitable for connection to air curtains
- › Free-hanging model (F): easy wall mounted installation
- › Cassette model (C): mounted into a false ceiling leaving only the decoration panel visible
- › Recessed model (R): neatly concealed in the ceiling
- › Provides virtually free air curtain heating via recovered heat from indoor units in cooling mode (in case of VRV heat recovery)
- › Easy and quick to install at reduced costs since no additional water systems, boilers and gas connections are required
- › **PATENTED TECHNOLOGY:** Maximum energy efficiency stemming from almost zero down flow turbulence, optimised air flow and the application of advanced discharge rectifier technology
- › Around 85% air separation efficiency, greatly reducing both heat loss and required indoor unit heating capacity

Packtime of less than 1.5 years

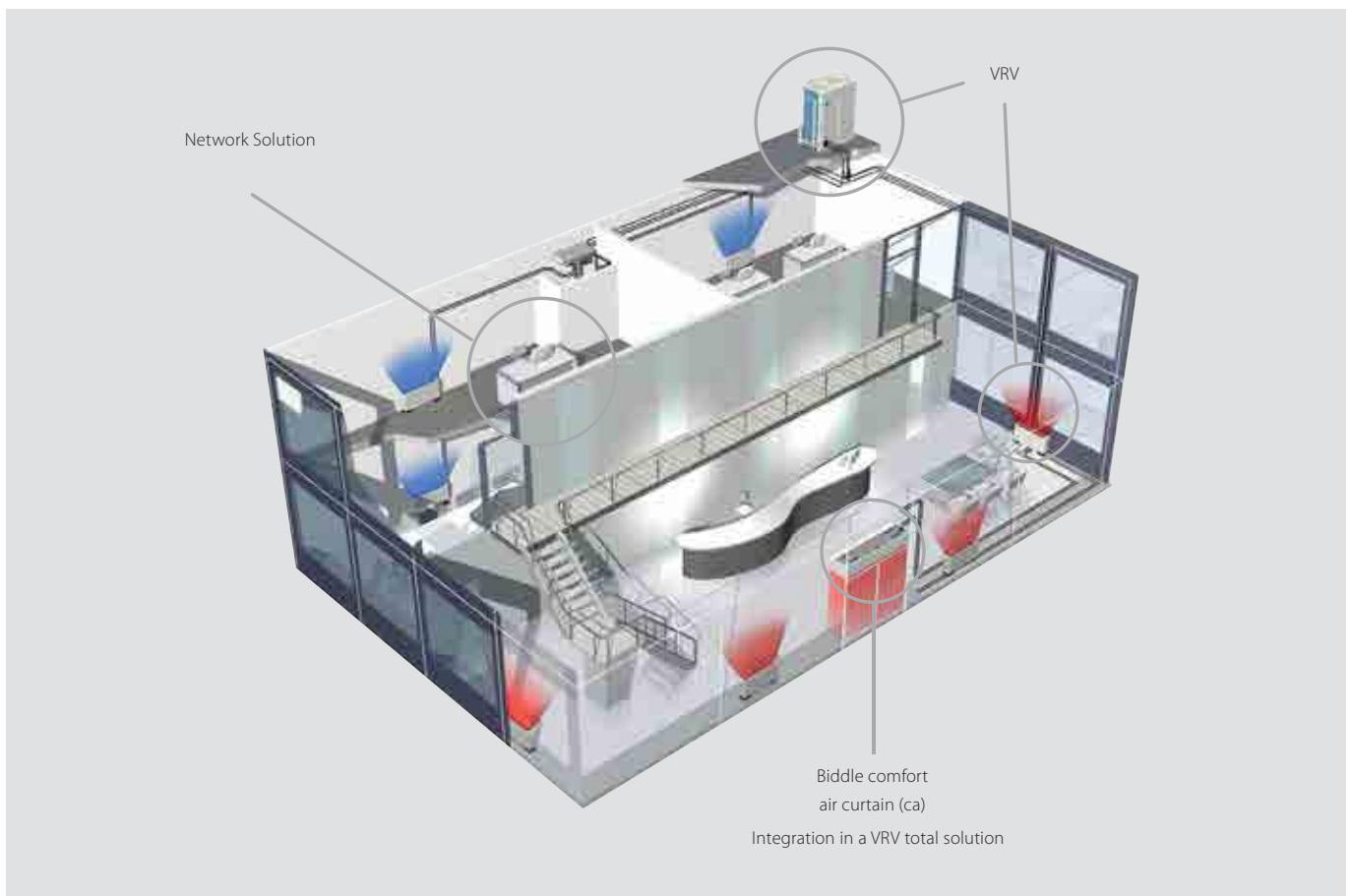
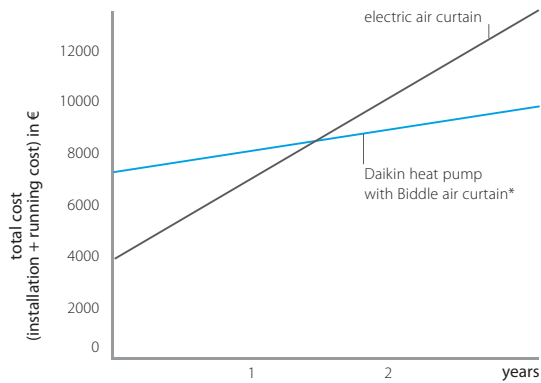

* Payback period and gains calculated based upon the following: Air curtain is 9hrs/day – 156 days year (1,404 hrs/year) in use. Annual energy consumption for an electric air curtain: 3,137EUR (COP = 0.95). Typical installation cost: 1,000EUR; Typical equipment cost: 2,793EUR. Annual energy consumption for CYQS200DK100FBN and ERQ100AV: 748EUR (COP 4.00). Typical installation cost: 2,000EUR; Typical equipment cost: 5,150EUR. Calculation based upon electricity cost: 0,1705EUR /kWh

Biddle air curtain for VRV



				Small				Medium				
				CYVS100DK80 *BN/*SN	CYVS150DK80 *BN/*SN	CYVS200DK100 *BN/*SN	CYVS250DK140 *BN/*SN	CYVM100DK80 *BN/*SN	CYVM150DK80 *BN/*SN	CYVM200DK100 *BN/*SN	CYVM250DK140 *BN/*SN	
Heating capacity	Speed 3		kW	7.40	9.0	11.6	16.2	9.2	11.0	13.4	19.9	
Power input	Fan only	Nom.	kW	0.23	0.35	0.46	0.58	0.37	0.56	0.75	0.94	
	Heating	Nom.	kW	0.23	0.35	0.46	0.58	0.37	0.56	0.75	0.94	
Delta T	Speed 3		K	19	15		16	17	14	13	15	
Casing	Colour			BN: RAL9010 / SN: RAL9006								
Dimensions	Unit	Height F/C/R	mm	270/270/270								
		Width F/C/R	mm	1,000/1,000/1,048	1,500/1,500/1,548	2,000/2,000/2,048	2,500/2,500/2,548	1,000/1,000/1,048	1,500/1,500/1,548	2,000/2,000/2,048	2,500/2,500/2,548	
		Depth F/C/R	mm	590/821/561								
Required ceiling void >			mm	420								
Door height	Max.		m	23 (1) / 215 (2) / 20 (3)	23 (1) / 215 (2) / 20 (3)	23 (1) / 215 (2) / 20 (3)	23 (1) / 215 (2) / 20 (3)	25 (1) / 24 (2) / 23 (3)	25 (1) / 24 (2) / 23 (3)	25 (1) / 24 (2) / 23 (3)	25 (1) / 24 (2) / 23 (3)	
Door width	Max.		m	1.0	1.5	2.0	2.5	1.0	1.5	2.0	2.5	
Weight	Unit		kg	56	66	83	107	57	73	94	108	
Fan-Air flow rate	Heating	Speed 3	m ³ /h	1,164	1,746	2,328	2,910	1,605	2,408	3,210	4,013	
Sound pressure level	Heating	Speed 3	dB(A)	47	49	50	51	50	51	53	54	
Refrigerant	Type / GWP			R-410A / 2,087,5								
Piping connections	Liquid/OD/Gas/OD		mm	9.52/16.0				9.52/19.0		9.52/16.0		9.52/19.0
Required accessories (should be ordered separately)				Daikin wired remote control (BRC1E52A/B or BRC1D52)								
Power supply	Voltage		V	230								

				Large			
				CYVL100DK125*BN/*SN	CYVL150DK200*BN/*SN	CYVL200DK250*BN/*SN	CYVL250DK250*BN/*SN
Heating capacity	Speed 3		kW	15.6	23.3	29.4	31.1
Power input	Fan only	Nom.	kW	0.75	1.13	1.50	1.88
	Heating	Nom.	kW	0.75	1.13	1.50	1.88
Delta T	Speed 3		K	15			14
Casing	Colour			BN: RAL9010 / SN: RAL9006			
Dimensions	Unit	Height F/C/R	mm	370/370/370			
		Width F/C/R	mm	1,000/1,000/1,048	1,500/1,500/1,548	2,000/2,000/2,048	2,500/2,500/2,548
		Depth F/C/R	mm	774/1,105/745			
Required ceiling void >			mm	520			
Door height	Max.		m	3.0 (1) / 2.75 (2) / 2.5 (3)	3.0 (1) / 2.75 (2) / 2.5 (3)	3.0 (1) / 2.75 (2) / 2.5 (3)	3.0 (1) / 2.75 (2) / 2.5 (3)
Door width	Max.		m	1.0	1.5	2.0	2.5
Weight	Unit		kg	76	100	126	157
Fan-Air flow rate	Heating	Speed 3	m ³ /h	3,100	4,650	6,200	7,750
Sound pressure level	Heating	Speed 3	dB(A)	53	54	56	57
Refrigerant	Type / GWP			R-410A / 2,087,5			
Piping connections	Liquid/OD/Gas/OD		mm	9.52/16.0	9.52/19.0	9.52/22.0	
Required accessories (should be ordered separately)				Daikin wired remote control (BRC1E52A/B or BRC1D52)			
Power supply	Voltage		V	230			

(1) Favorable conditions: covered shopping mall or revolving door entrance (2) Normal conditions: little direct wind, no opposite open doors, building with ground floor only (3) Unfavorable conditions: location at a corner or square, multiple floors and/or open stairway

CYVS_DK_FBN/FSN / CYVM_DK_FBN/FSN / CYVL_DK_FBN/FSN

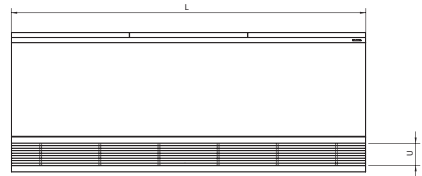
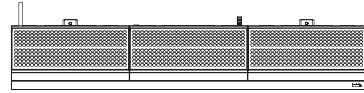
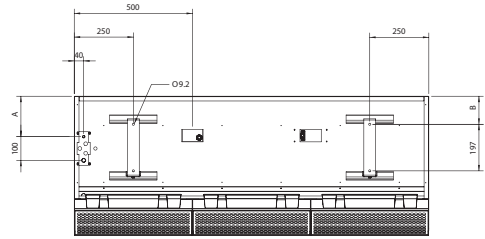
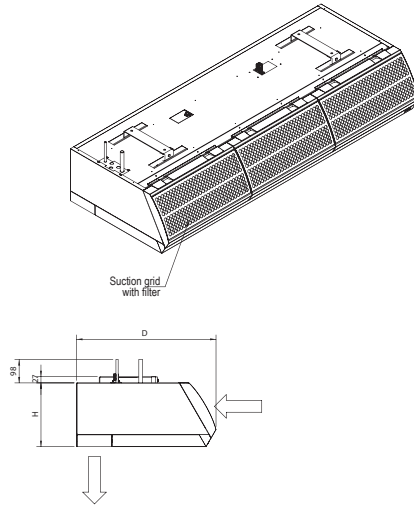

Type	L	H	D	U	A	B
CYVS-DK-FBN/FSN	1,000 - 1,500	270	590	93	171	119
CYVM-DK-FBN/FSN	2,000 - 2,500					
CYVL-DK-FBN/FSN	1,000 - 1,500	370	774	124.5	245.5	200
	2,000 - 2,500					

CU0954X-000

REMARKS

- The 2,500mm large devices have 3 suspension brackets, where the third bracket is mounted at half the length of the device.

CYVS_DK_CBN/CSN / CYVM_DK_CBN/CSN / CYVL_DK_CBN/CSN

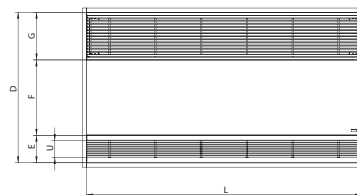
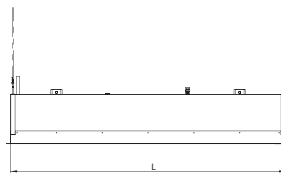
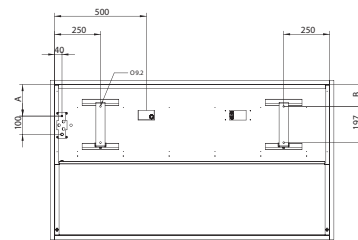
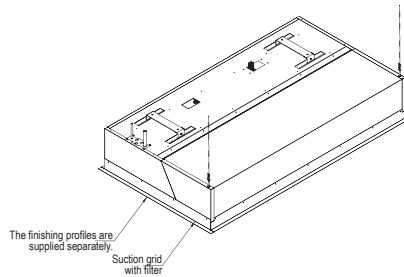

Number of suction grids per device

Device length	Number	Suction grid length
1000 / 1500	1	1,000 / 1,500
2000 / 2500	2	1,000 / 1,250

*1 drain grid per device

Type	L	H	D	U	A	B	E	F	G
CYVS-DK-CBN/CSN	1,000 - 1,500	270	821	93	171	119	250	411	260
CYVM-DK-CBN/CSN	2,000 - 2,500								
CYVL-DK-CBN/CSN	1,000 - 1,500	370	1,105	124.5	245.5	200	181.5	563.5	360
	2,000 - 2,500								

CU0955X-000

REMARKS

- The 2,500mm large devices have 3 suspension brackets, where the third bracket is mounted at half the length of the device.
- The mounting holes for finishing profiles in a lowered ceiling (L+8) x (D+8) mm

CYVS_DK_RBN/RSN / CYVM_DK_RBN/RSN / CYVL_DK_RBN/RSN

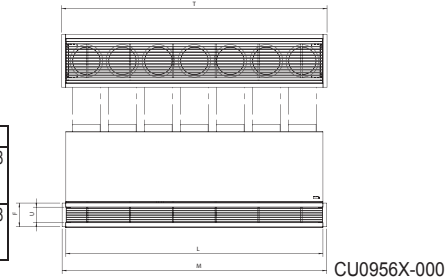
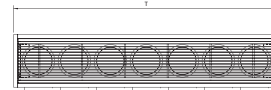
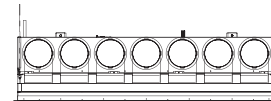
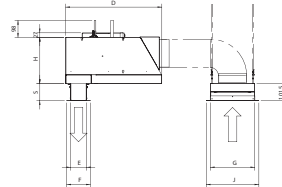
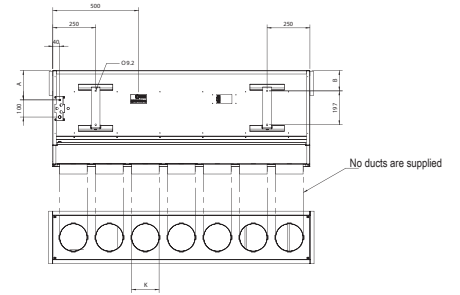
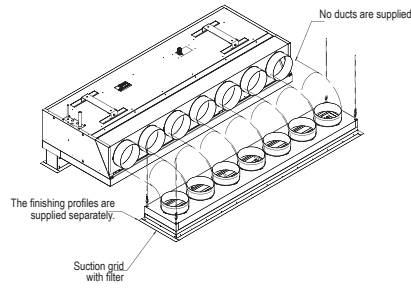

Number of ducts per device

Type	1000	1500	2000	2500
CYVS-DK-RBN/RSN	5	7	10	12
CYVM-DK-RBN/RSN	5	7	10	12
CYVL-DK-RBN/RSN	3	5	6	8

Number of suction grids per device

Device length	Number	Suction grid length
1000 / 1500	1	1,000 / 1,500
2000 / 2500	2	1,000 / 1,250

*1 drain grid per device

Type	L	H	D	S	U	A	B	E	F	G	J	K	M	T
CYVS-DK-RBN/RSN	1,000 - 1,500	270	561	80-125	90	171	119	92	139	260	308	Ø160	1044-1544 2044-2544	1048-1548 2048-2548
CYVM-DK-RBN/RSN	1,000 - 1,500 2,000 - 2,500	270	561	80-125	90	171	119	92	139	260	308	Ø160	1044-1544 2044-2544	1048-1548 2048-2548
CYVL-DK-RBN/RSN	1,000 - 1,500 2,000 - 2,500	370	745	80-125	121.5	245.5	200	123.5	170	360	408	Ø250	1044-1544 2044-2544	1048-1548 2048-2548

REMARKS

- 1 The 2,500mm large devices have 3 suspension brackets, where the third bracket is mounted at half the length of the device.
- 2 Holes (for finishing profiles) - drain (L+8) x (E+8) mm - suction (L+8) x (G+8) mm.



Ventilation & air handling

Daikin offers the widest range in DX ventilation in the market.

With a variety of ventilation solutions from small heat recovery ventilation to large scale air handling units we help provide a fresh, healthy and comfortable environment in offices, hotels, stores and other commercial environments.

Ventilation & air handling

Ventilation

Heat reclaim ventilation	
VAM-FA/FB	186
VKM-GB(M)	198

Air handling applications	
Overview & control possibilities	209
VRV	212
ERQ	214
Expansion valves and control boxes	215





DAIKIN AIR HANDLING UNIT AND ERQ/VRV PLUG & PLAY CONNECTION



Ventilation & Air Handling

Heat reclaim ventilation

Ventilation with heat recovery as standard

- › Energy saving ventilation using indoor heating, cooling and moisture recovery
- › Ideal solution for shops, restaurants or offices requiring maximum floor space for furniture, decorations and fittings
- › Free cooling possible when outdoor temperature is below indoor temperature (eg. during nighttime)
- › Reduced energy consumption thanks to specially developed DC fan motor
- › Prevent energy losses from over-ventilation while maintaining indoor air quality with optional CO₂ sensor
- › Can be used as stand alone unit or integrated in the VRV system
- › Wide range of units: air flow rate from 150 up to 2,000 m³/h
- › High efficiency filters available in F6 ,F7, F8 grades
- › Shorter installation time thanks to easy adjustment of nominal air flow rate, so less need for dampers compared with traditional installation.
- › Specially developed heat exchange element with High Efficiency Paper (HEP)
- › No drain piping needed
- › Can operate in over- and under pressure
- › Total solution for fresh air with Daikin supply of both VAM and electrical heaters

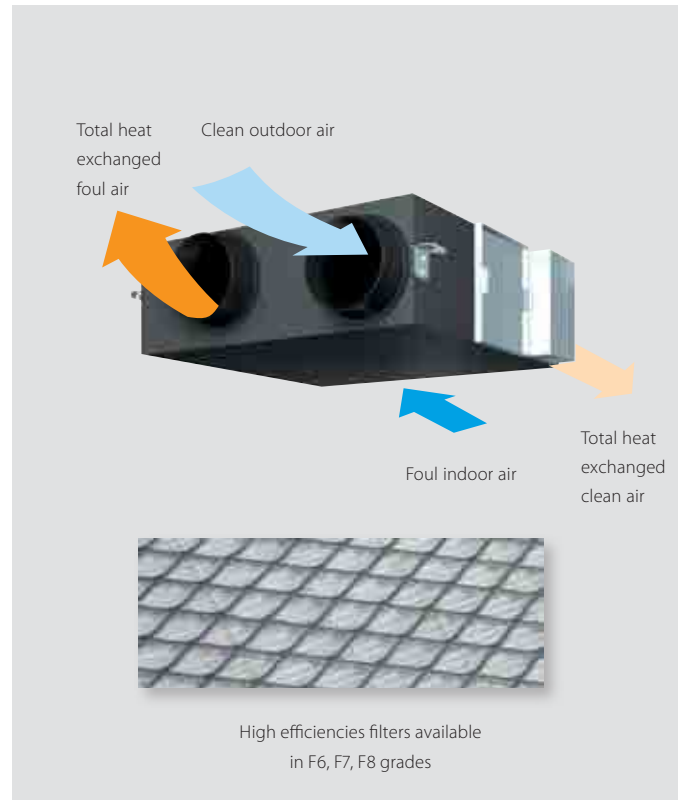

Prevent energy losses from over ventilation with CO₂ sensor

Enough fresh air is needed to create an enjoyable environment, but ventilating constantly is leading to energy waste. Therefore an optional CO₂ sensor can be installed which switches off the ventilation system when there is enough fresh air in the room, thus saving energy.

Example of CO₂ sensor operation in a meeting room:

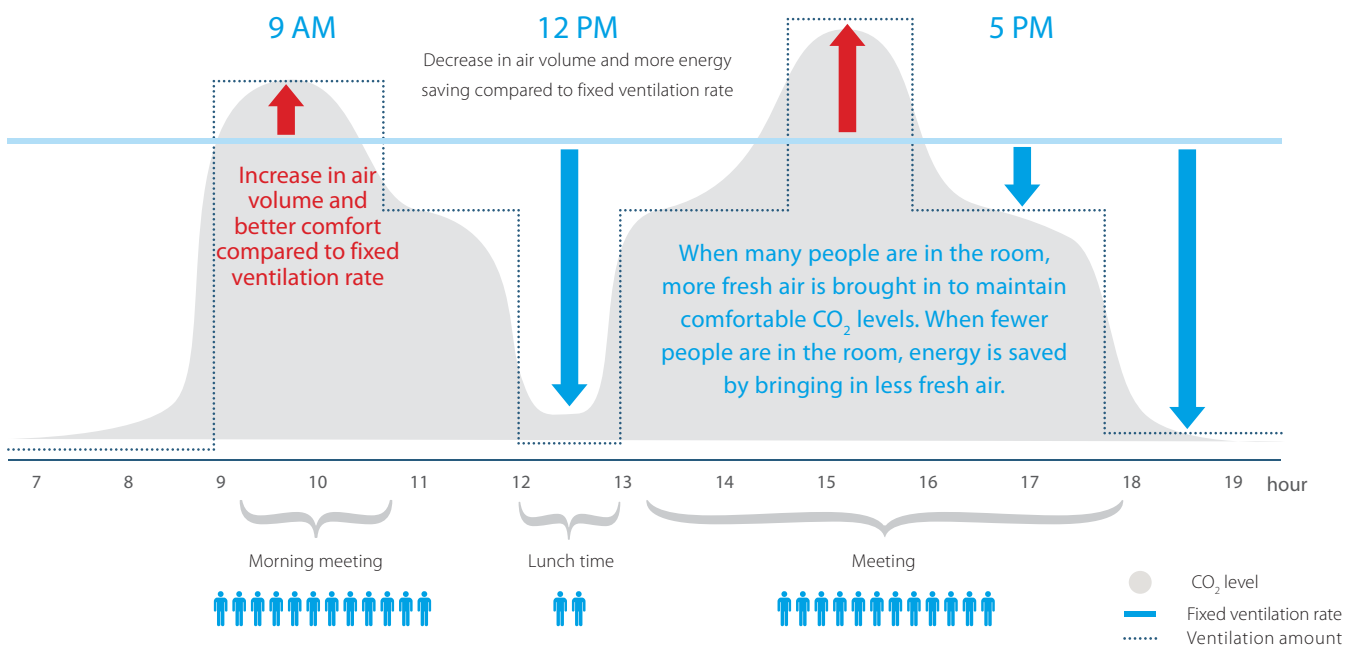

Using CO₂ sensors has the most energy-saving potential in buildings where occupancy fluctuates during a 24-hour period, is unpredictable and peaks at a high level. For example office buildings, government facilities, retail stores and shopping malls, movie theaters, auditoriums, schools, entertainment clubs and nightclubs. The ventilation unit's reaction to fluctuations in CO₂ can be easily adjusted by the customer.

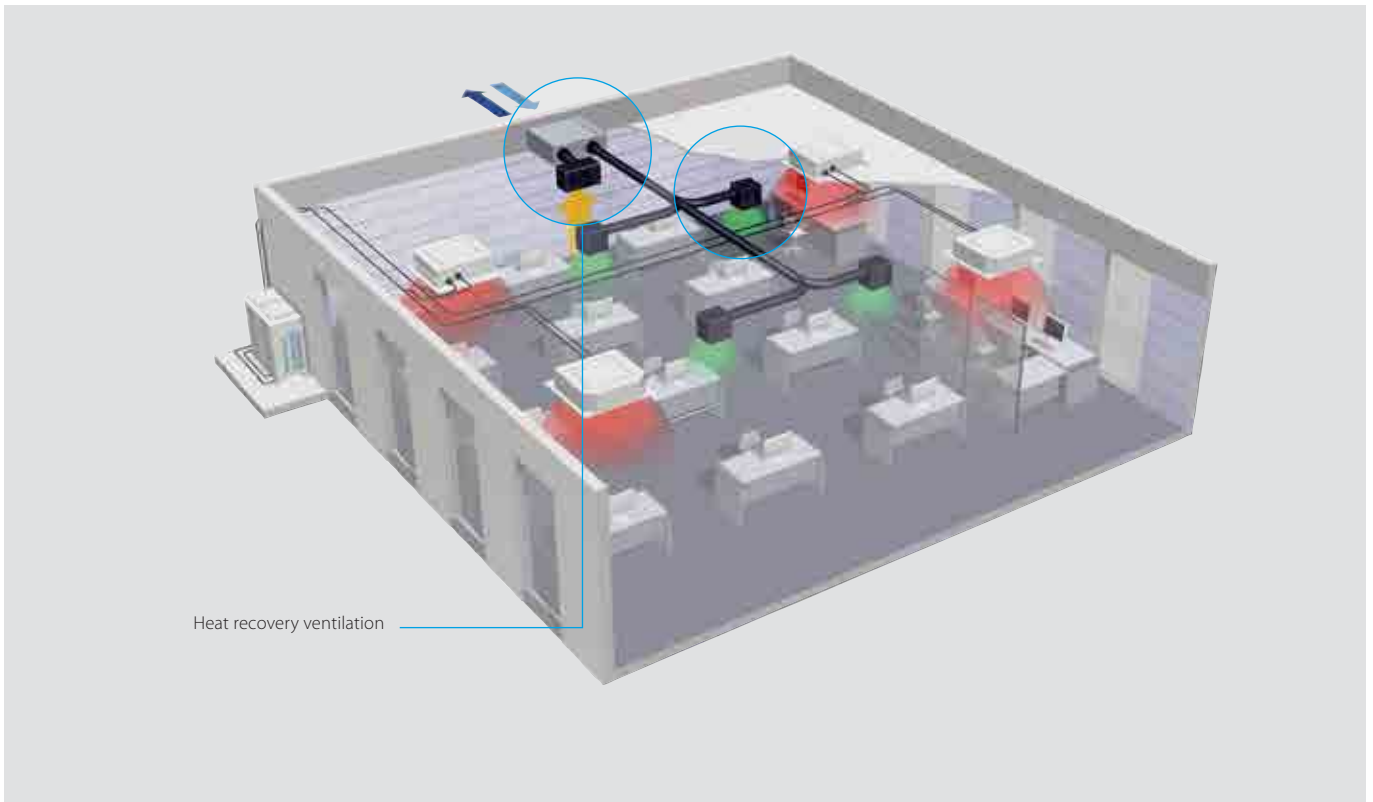

High Efficiency Paper

Operation of the high efficiency paper.

Cross flow of air to exchange heat and moisture.

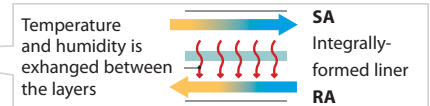
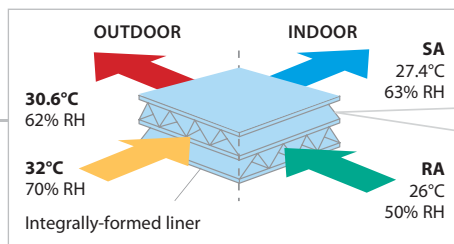

RH: Relative Humidity SA: Supply Air (to room) RA: Return Air (from room)

Ventilation		VAM	150FA	250FA	350FB	500FB	650FB	800FB	1000FB	1500FB	2000FB				
Power input - 50Hz	Heat exchange mode	Nom.	Ultra high	kW		0.116	0.141	0.132	0.178	0.196	0.373	0.375	0.828	0.852	
	Bypass mode	Nom.	Ultra high	kW		0.116	0.141	0.132	0.178	0.196	0.373	0.375	0.828	0.852	
Temperature exchange efficiency - 50Hz	Ultra high/High/Low		%		74/74/79	72/72/77	75/75/80	74/74/77	74/74/76	75/75/76.5	75/75/78				
Enthalpy exchange efficiency - 50Hz	Cooling	Ultra high/High/Low	%		58/58/64	58/58/62	61/61/67	58/58/63	60/60/62	61/61/63	61/61/64	61/61/66			
	Heating	Ultra high/High/Low	%		64/64/69	64/64/68	65/65/70	62/62/67	63/63/66	65/65/67	66/66/68	66/66/70			
Operation mode	Heat exchange mode / Bypass mode / Fresh-up mode														
Heat exchange system	Air to air cross flow total heat (sensible + latent heat) exchange														
Heat exchange element	Specially processed non-flammable paper														
Dimensions	Unit	HeightxWidthxDepth	mm		285x776x525	301x828x816		364x1,004x868		364x1,004x1,156	726x1,512x868	726x1,512x1,156			
Weight	Unit	kg		24	33		52	55	64	131	152				
Casing	Galvanised steel plate														
Fan-Air flow rate - 50Hz	Heat exchange mode	Ultra high	m ³ /h		150	250	350	500	650	800	1,000	1,500	2,000		
	Bypass mode	Ultra high	m ³ /h		150	250	350	500	650	800	1,000	1,500	2,000		
Fan-External static pressure - 50Hz	Ultra high	Pa		69	64	98		93	137	157	137				
	High	Pa		39											
	Low	Pa		20											
Air filter	Multidirectional fibrous fleeces														
Sound pressure level - 50Hz	Heat exchange mode	Ultra high	dBA		27 / 28.5	28 / 29	32	33	34.5	36	39.5	40			
	Bypass mode	Ultra high	dBA		27 / 28.5	28 / 29	32	33.5	34.5	36	40.5	40			
Operation range	Min.	°CDB						-15							
	Max.	°CDB						50							
	Relative humidity	%						80% or less							
Refrigerant	Type / GWP														
Connection duct diameter	mm		100	150		200		250		350					
Power supply	Phase/Frequency/Voltage		Hz/V				1~/50/60/220-240/220								
Current	Maximum fuse amps (MFA)		A		15				16						

VH

- › Total solution for fresh air with Daikin supply of both VAM and electrical heaters
- › Increased comfort in low outdoor temperature thanks to the heated outdoor air
- › Integrated electrical heater concept (no additional accessories required)
- › Standard dual flow and temperature sensor
- › Flexible setting with adjustable setpoint
- › Increased safety with 2 cut-outs: manual & automatic
- › BMS integration thanks to:
 - Volt free relay for error indication
 - 0-10VDC input for setpoint control



ELECTRICAL HEATER FOR VAM	VH	(VH)
Supply voltage		220/250V ac 50/60 Hz. +/-10%
Output current (maximum)		19A at 40°C (ambient)
Temperature sensor		5k ohms at 25°C (table 502 1T)
Temperature control range		0 to 40°C / (0-10V 0-100%)
Control fuse		20 x 5mm 250mA
LED indicators		Power ON - Yellow Heater ON - Red (solid or flashing, indicating pulsed control) Airflow fault - Red
Mounting holes		98mm x 181mm centres 5 mm ø holes
Maximum ambient adjacent to terminal box		35°C (during operation)
Auto high temp. cutout		100°C Pre-set
Man. reset high temp. cutout		125°C Pre-set
Run relay		1A 120V AC or 1A 24V DC
BMS setpoint input		0-10VDC

		VH	1B	2B	3B	4B	4/AB	5B
Capacity	kW		1	1	1	1.5	2.5	2.5
Duct diameter	mm		100	150	200	250	250	300
Connectable VAM			VAM150FA -	VAM250FA VAM350FB	VAM500FB VAM650FB	VAM800FB VAM1000FB	VAM800FB VAM1000FB	VAM1500FB VAM2000FB

For the selection of the appropriate capacity, please refer to the VAM selection software.

VAM150FA

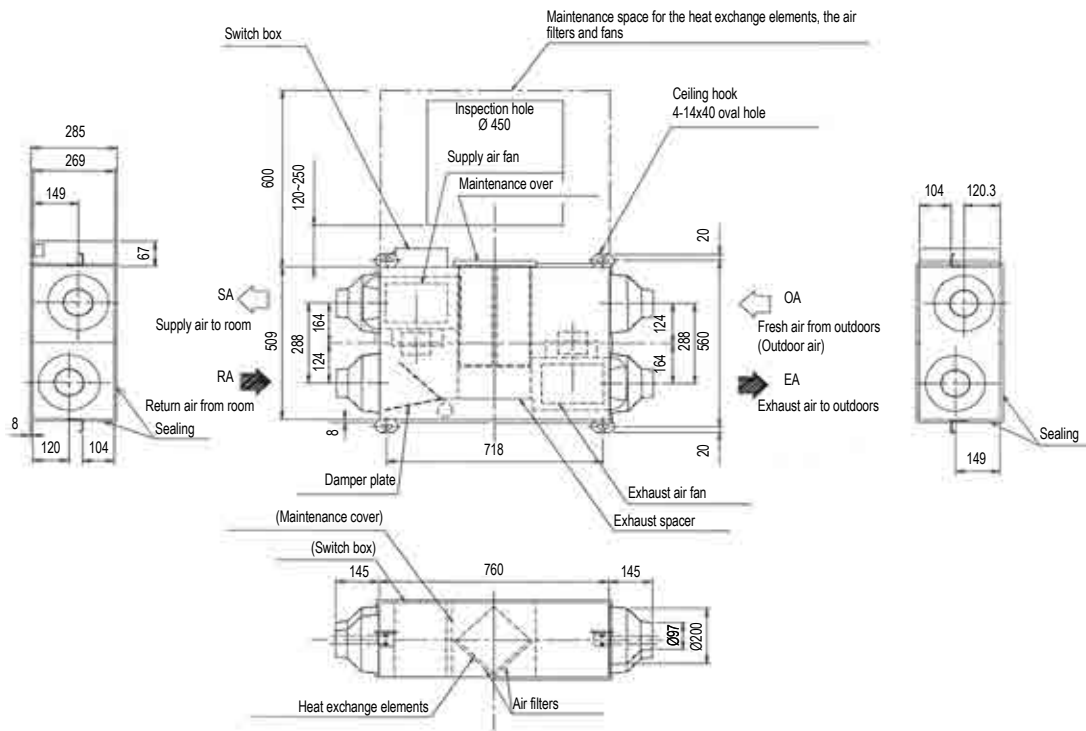

NOTE

- 1 Be sure to provide the inspection hole (450x450 mm) to inspect the air filters, the exchange elements and fans.

VAM250FA

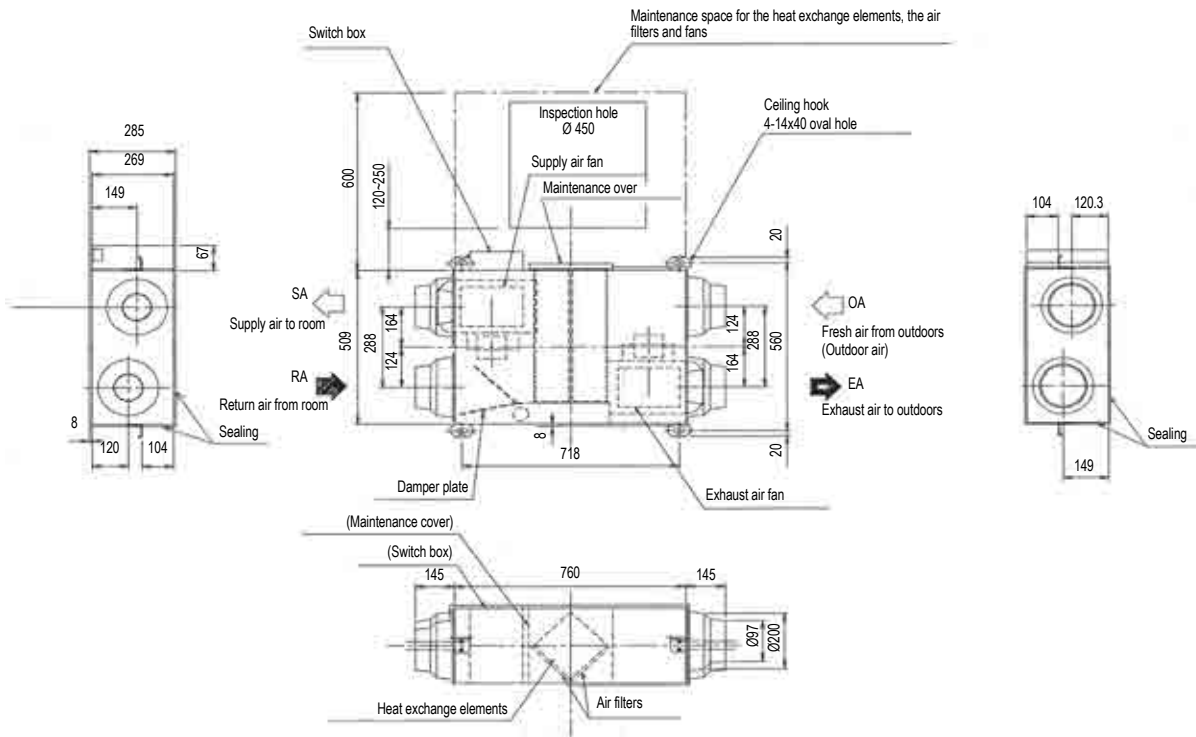

NOTE

- 1 Be sure to provide the inspection hole (450x450 mm) to inspect the air filters, the exchange elements and fans.

VAM350FB

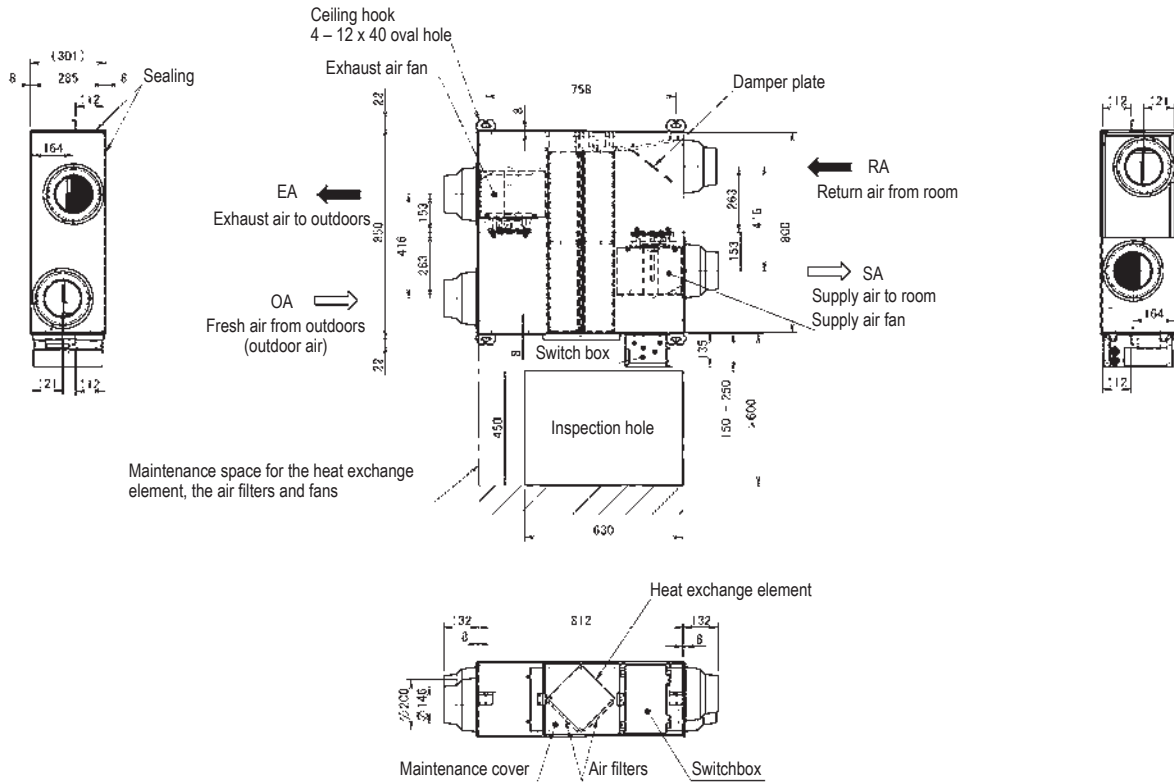

NOTES

1. Be sure to provide the inspection hole to inspect the air filters, the exchange elements and fans.

3D081162

VAM500FB

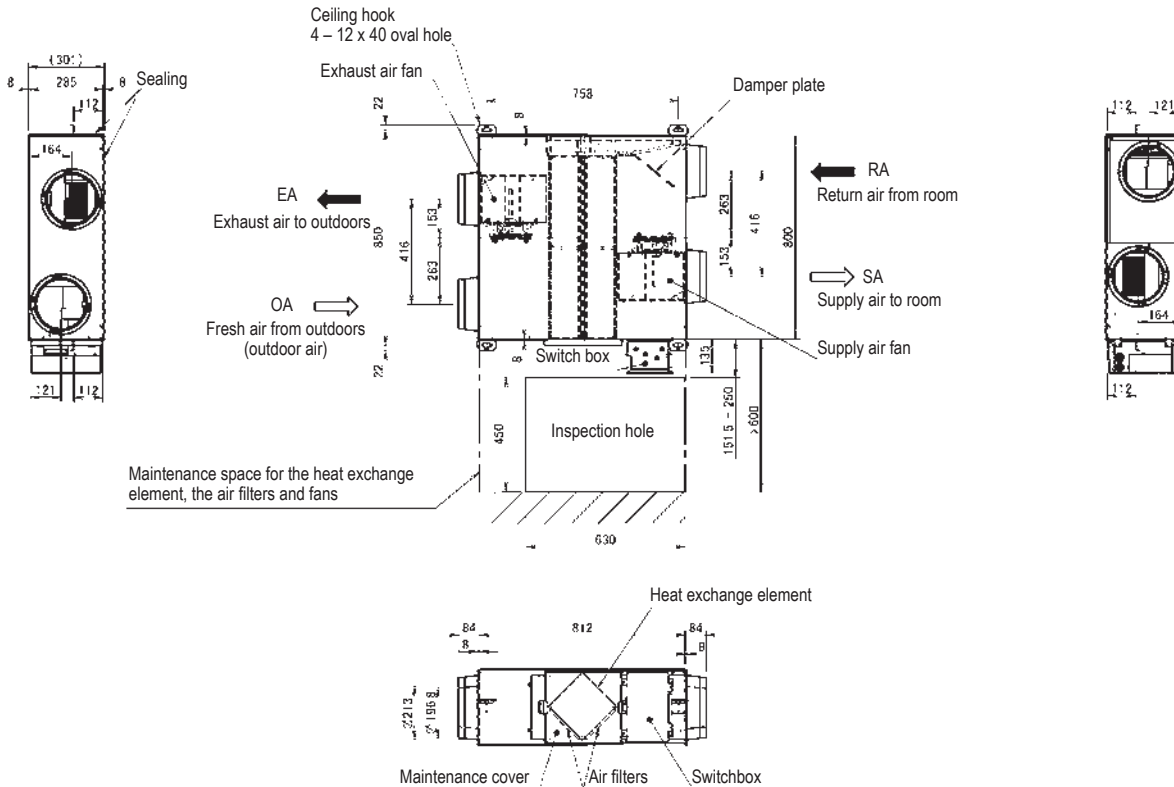

NOTES

1. Be sure to provide the inspection hole to inspect the air filters, the exchange elements and fans.

3D081163

VAM650FB

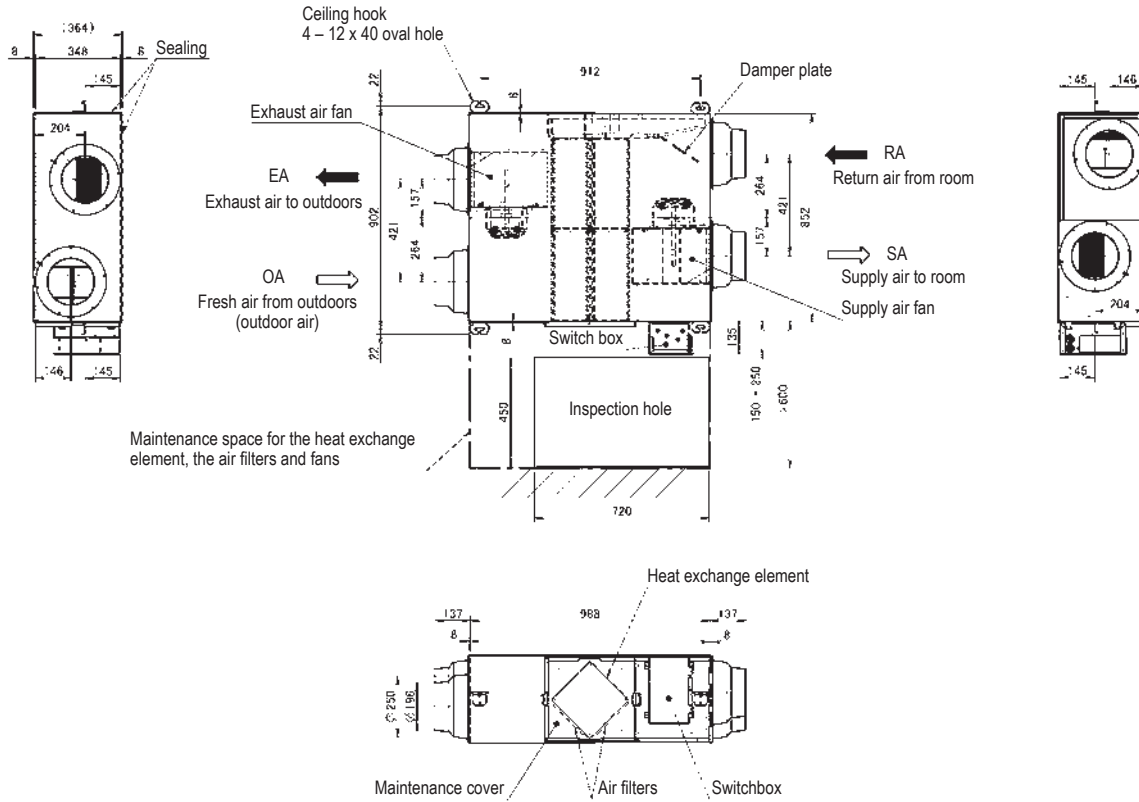

NOTES

1. Be sure to provide the inspection hole to inspect the air filters, the exchange elements and fans.

3D081164

VAM800FB

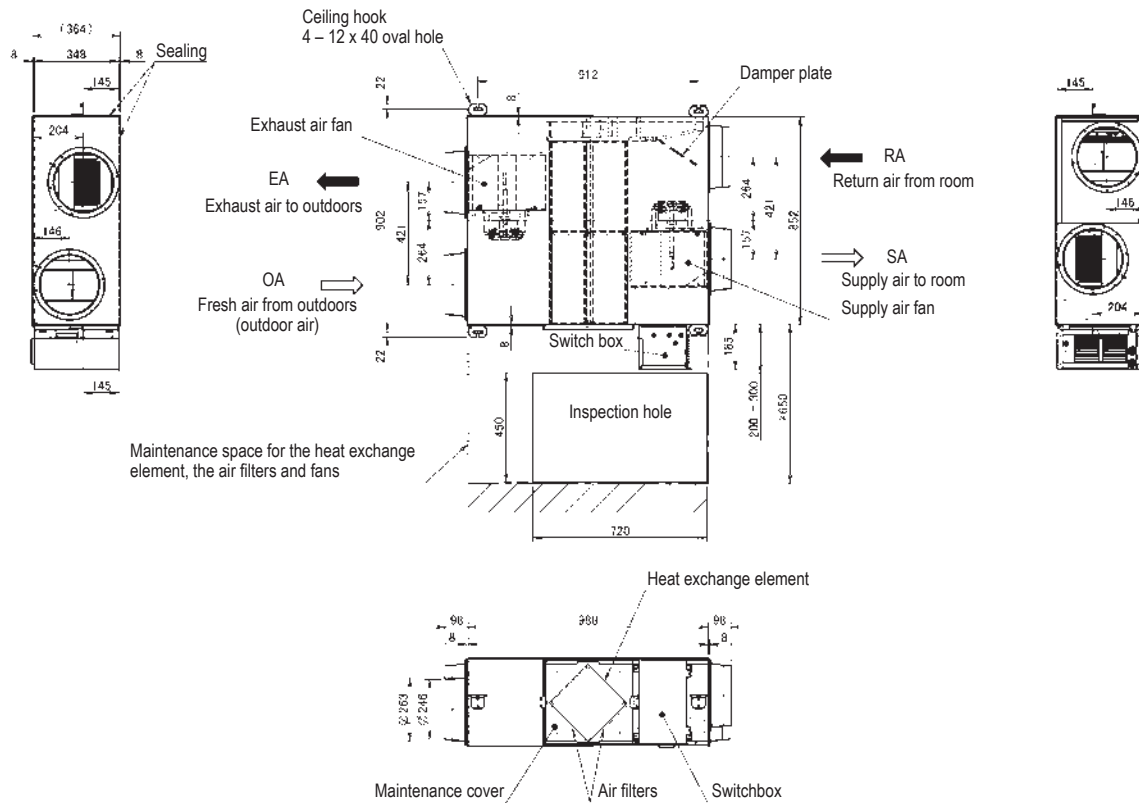

NOTES

1. Be sure to provide the inspection hole to inspect the air filters, the exchange elements and fans.

3D081165

VAM1000FB

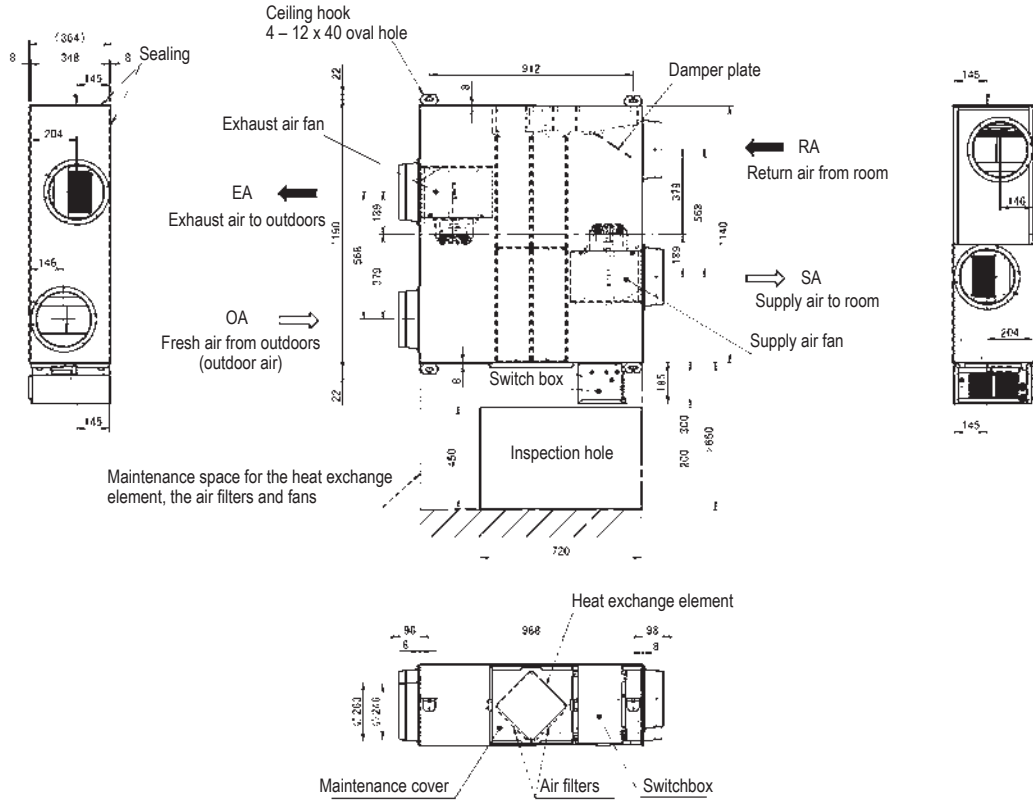

NOTES

- 1. Be sure to provide the inspection hole to inspect the air filters, the exchange elements and fans.

3D081166

VAM1500FB

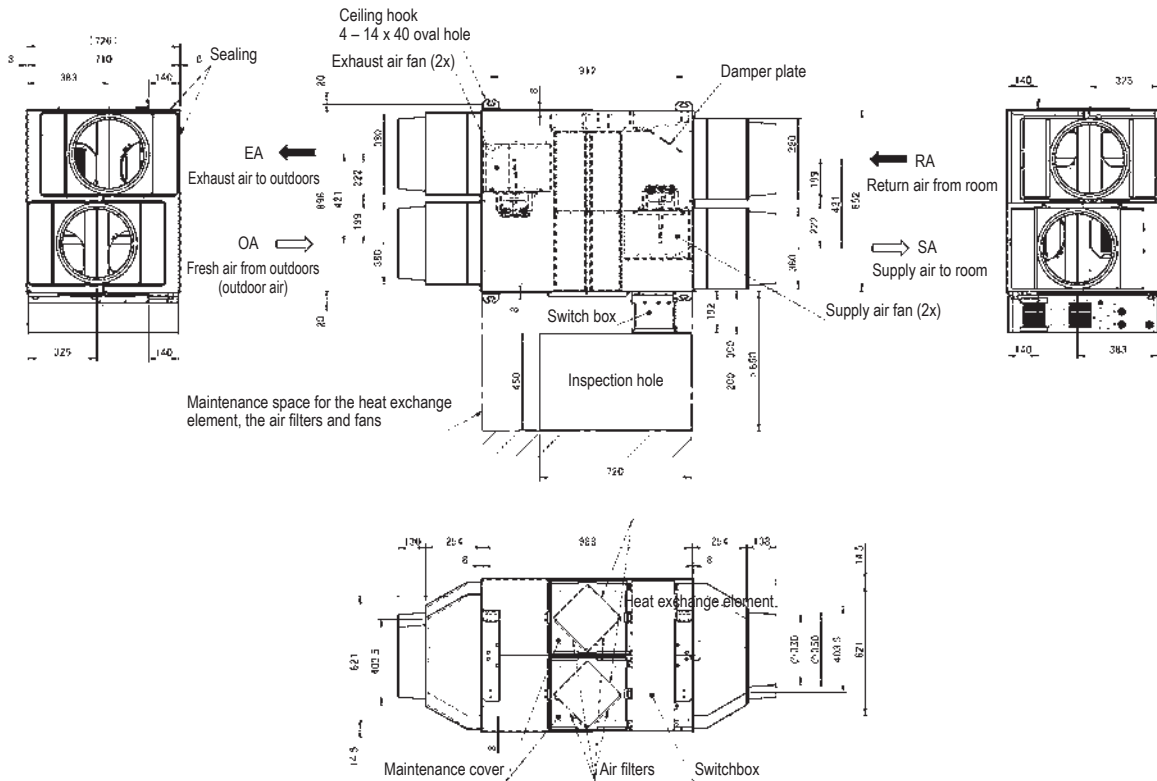

NOTES

- 1. Be sure to provide the inspection hole to inspect the air filters, the exchange elements and fans.

3D081167

VAM2000FB

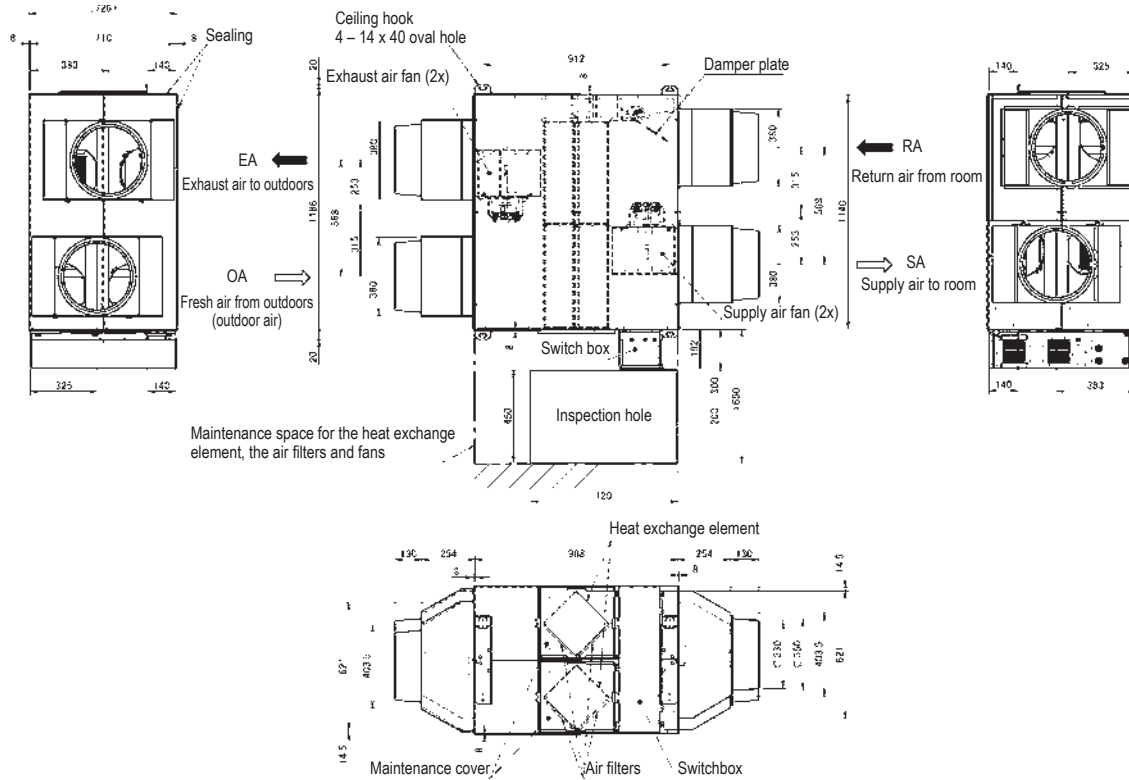

NOTES

1. Be sure to provide the inspection hole to inspect the air filters, the exchange elements and fans.

3D081168

VAM150FA

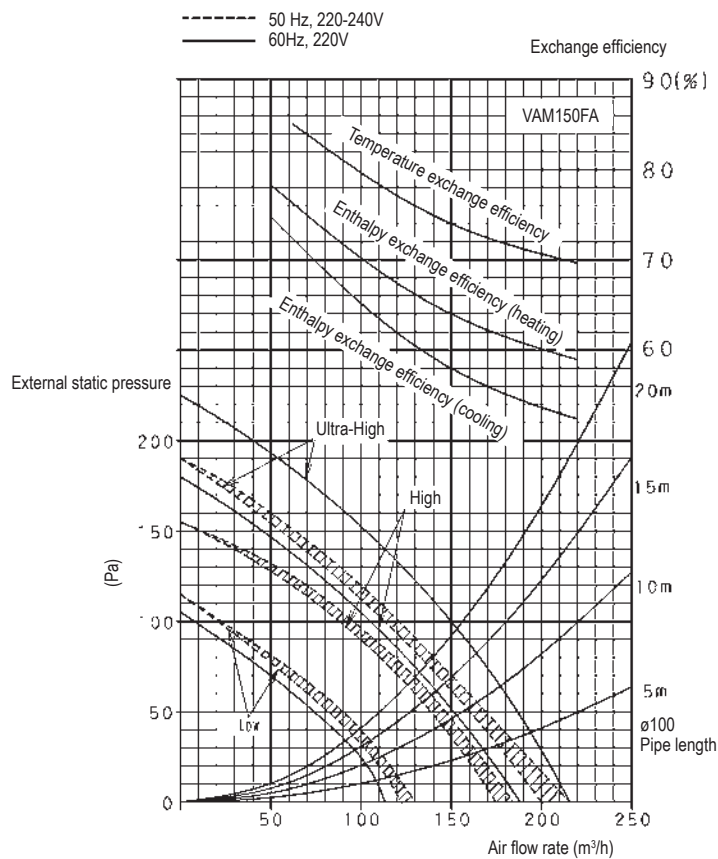

VAM250FA

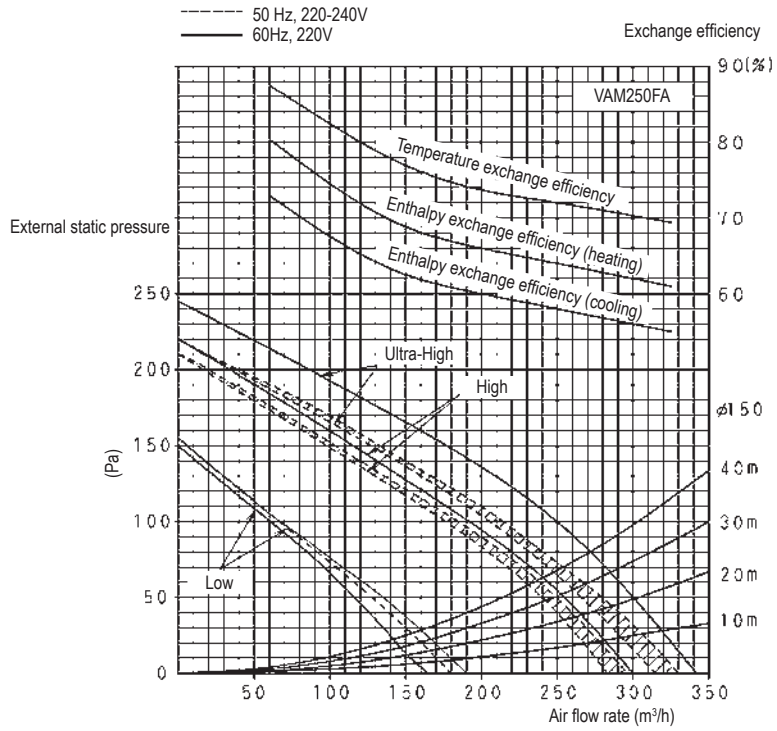

VAM350FA

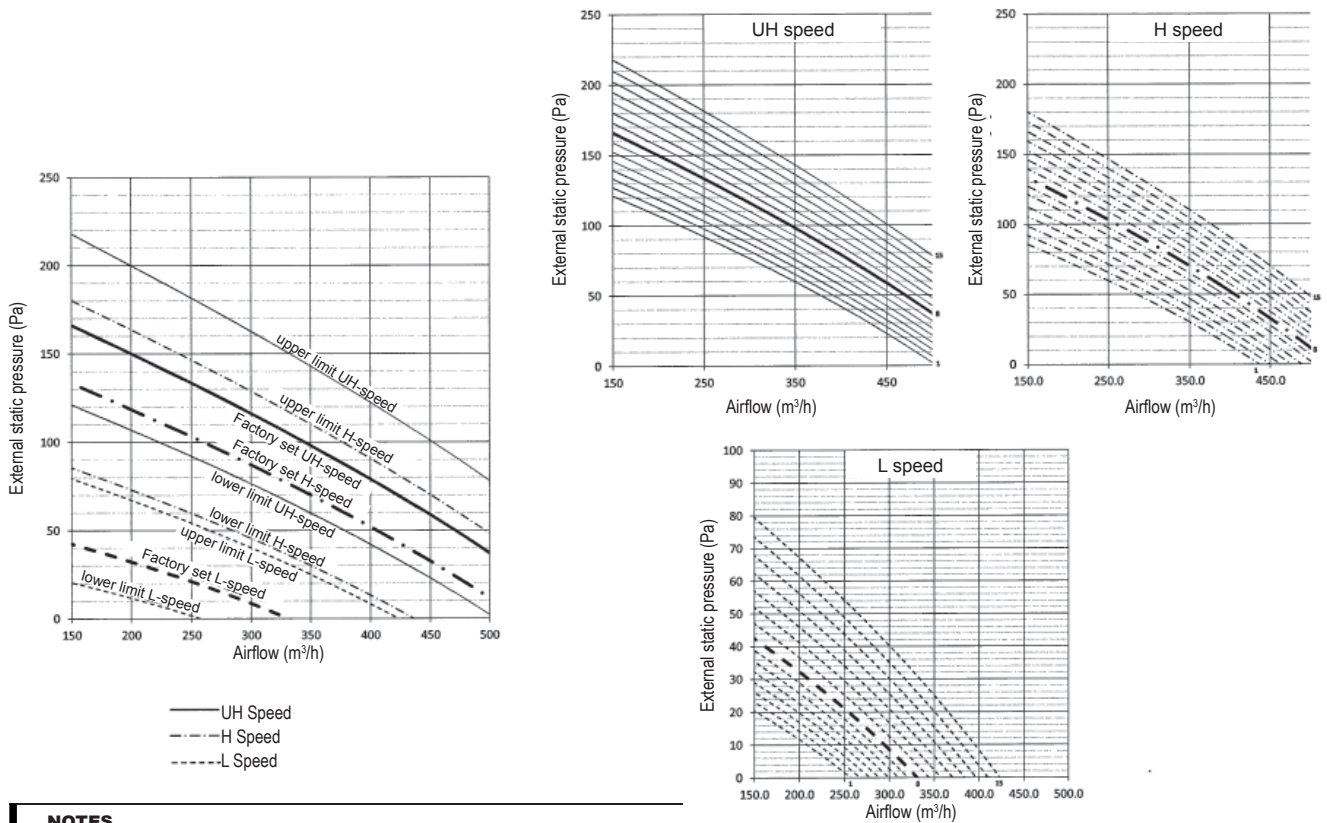

NOTES

VAM500FA

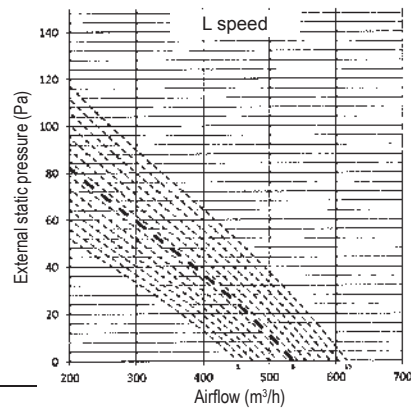
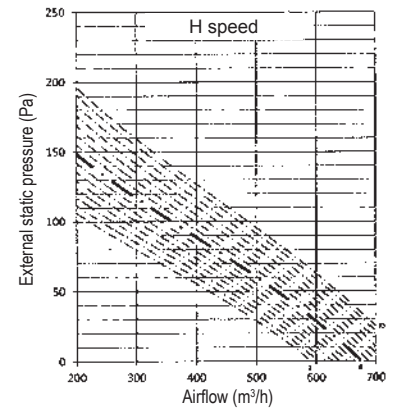
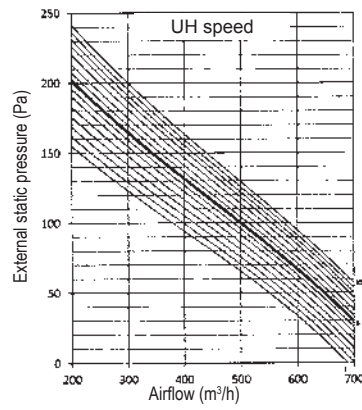
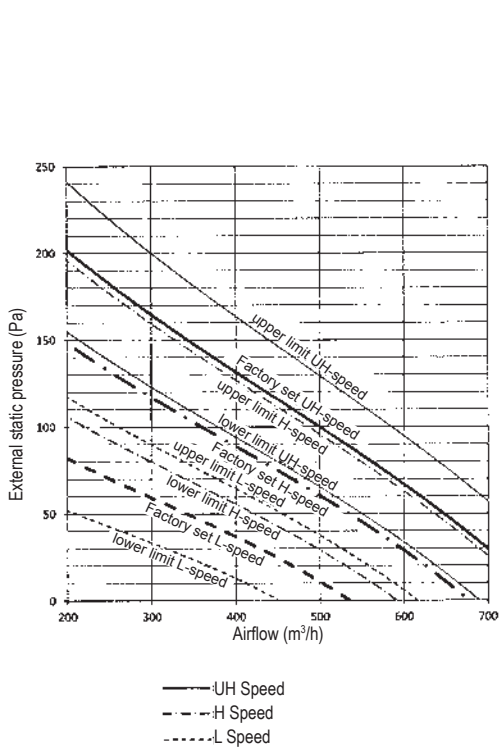

NOTES

VAM650FA

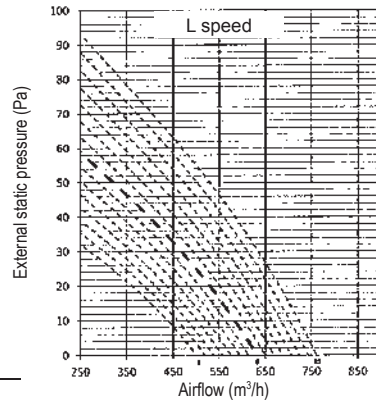
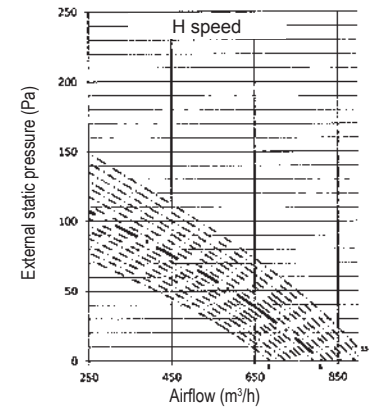
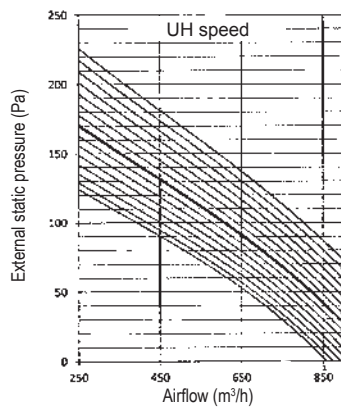
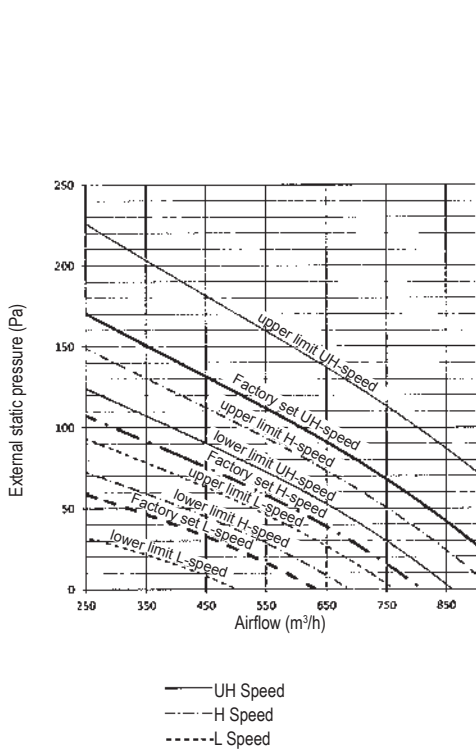

NOTES

VAM800FB

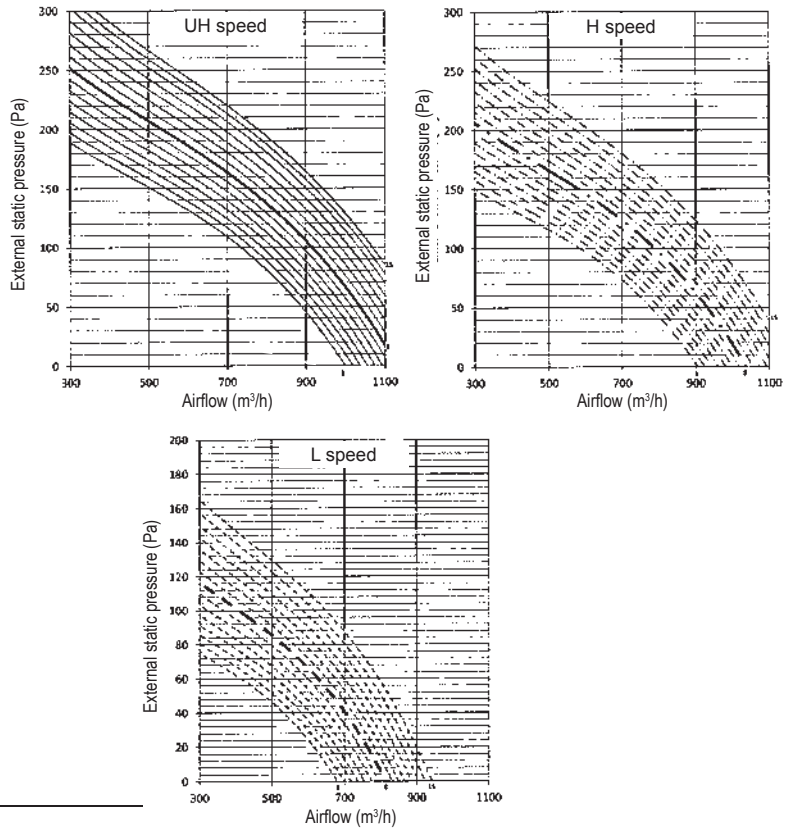
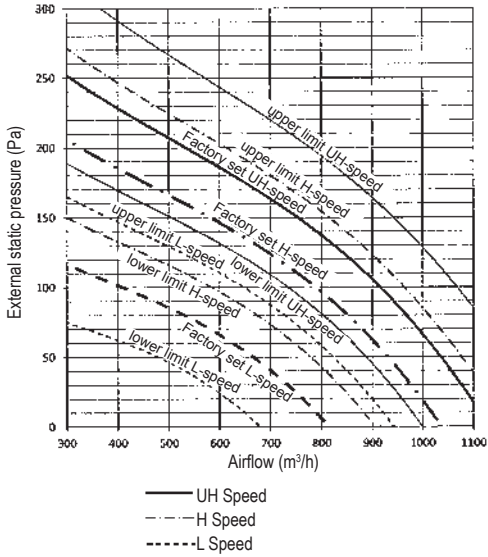

NOTES

1. The fan speeds are valid for 230V 50Hz power supply

3D082180

VAM1000FB

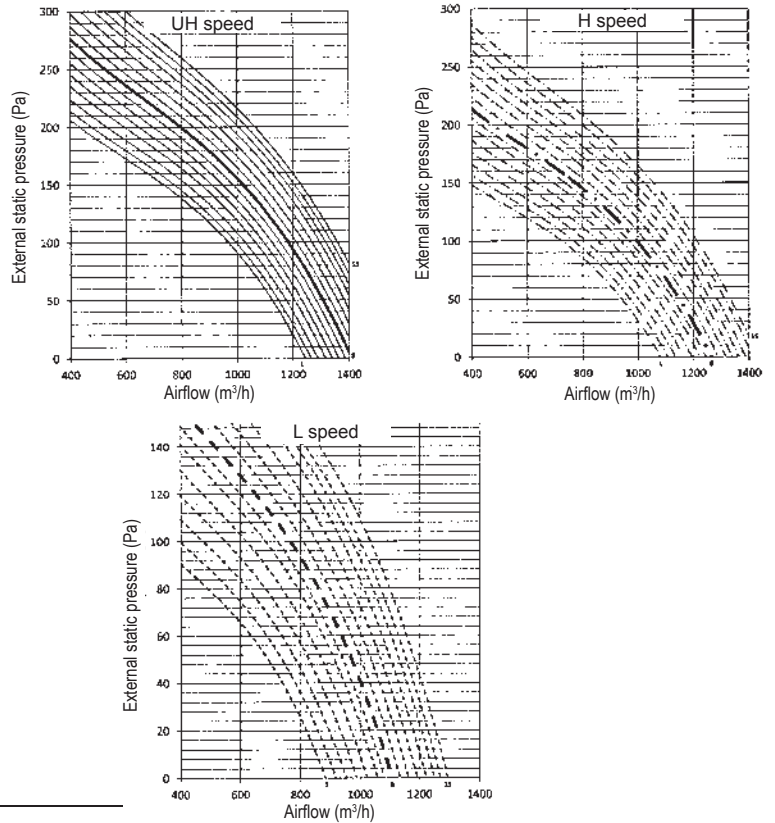
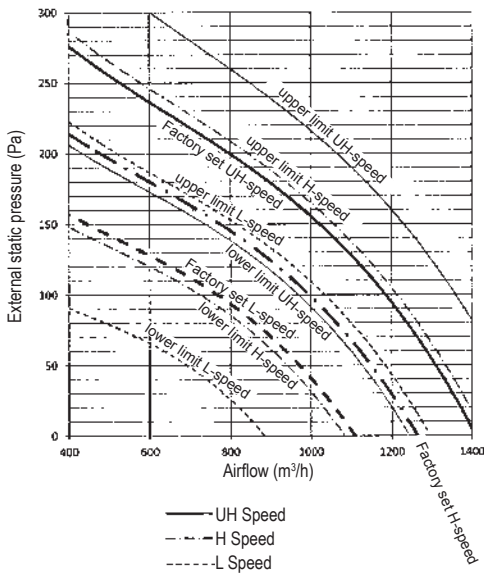

NOTES

1. The fan speeds are valid for 230V 50Hz power supply

3D082181

VAM1500FB

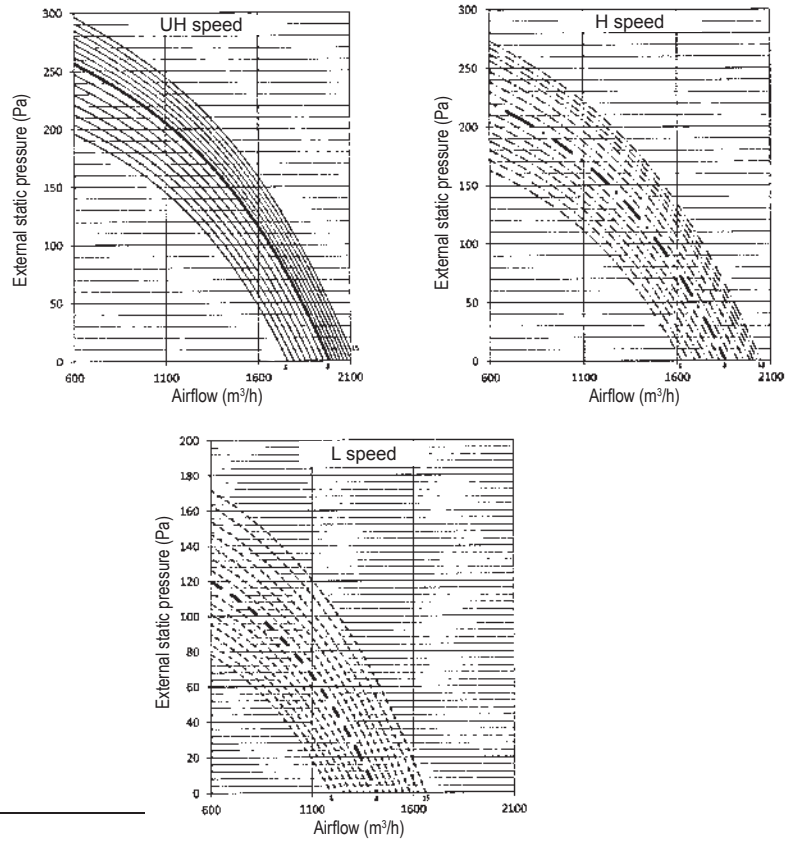
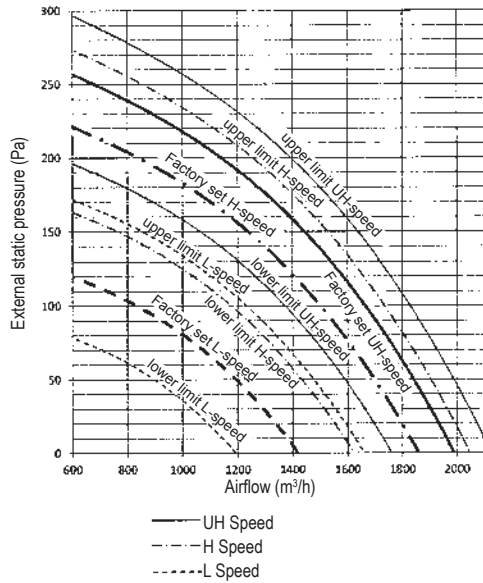

NOTES

1. The fan speeds are valid for 230V 50Hz power supply

3D082182

VAM2000FB

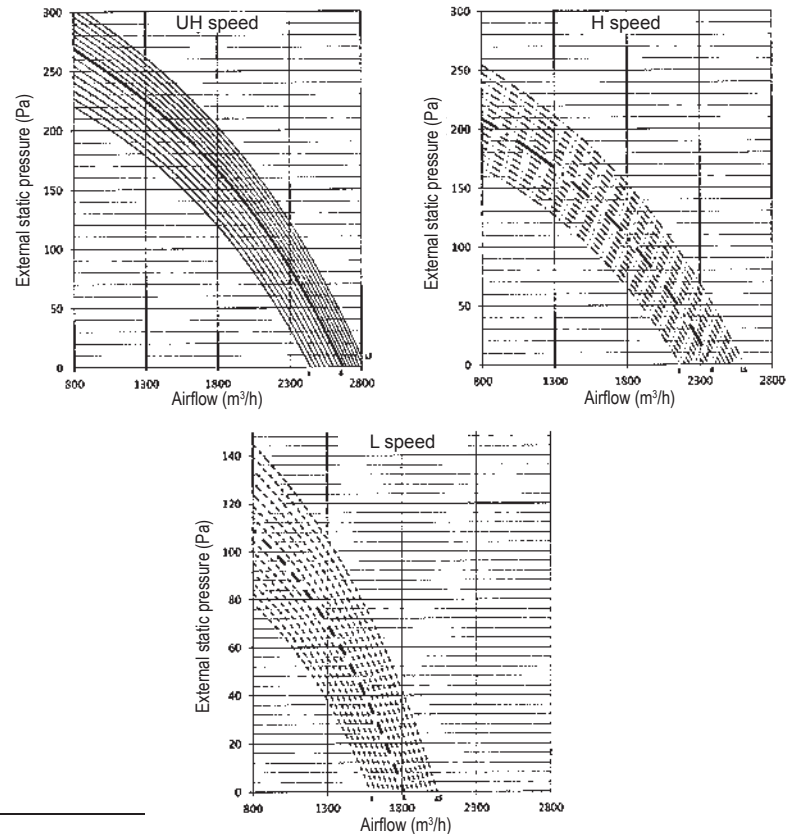
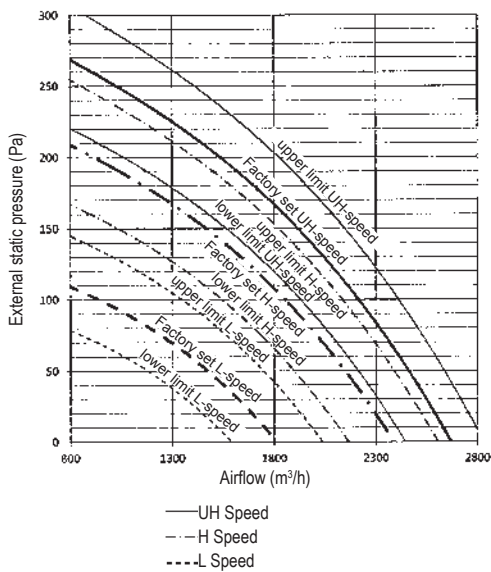

NOTES

1. The fan speeds are valid for 230V 50Hz power supply

3D082183

Heat reclaim ventilation and air processing

Pre heating or cooling of fresh air for lower load on the air conditioning system

- › Energy saving ventilation using indoor heating, cooling and moisture recovery
- › Creates a high quality indoor environment by pre conditioning incoming fresh air
- › Humidification of the incoming air results in comfortable indoor humidity level, even during heating
- › Ideal solution for shops, restaurants or offices requiring maximum floor space for furniture, decorations and fittings
- › Free cooling possible when outdoor temperature is below indoor temperature (eg. during nighttime)
- › Low energy consumption thanks to DC fan motor
- › Prevent energy losses from over-ventilation while maintaining indoor air quality with optional CO2 sensor
- › Shorter installation time thanks to easy adjustment of nominal air flow rate, so less need for dampers compared with traditional installation.
- › Specially developed heat exchange element with High Efficiency Paper (HEP)
- › Can operate in over- and under pressure



Operation example: humidification & air processing (heating mode)¹

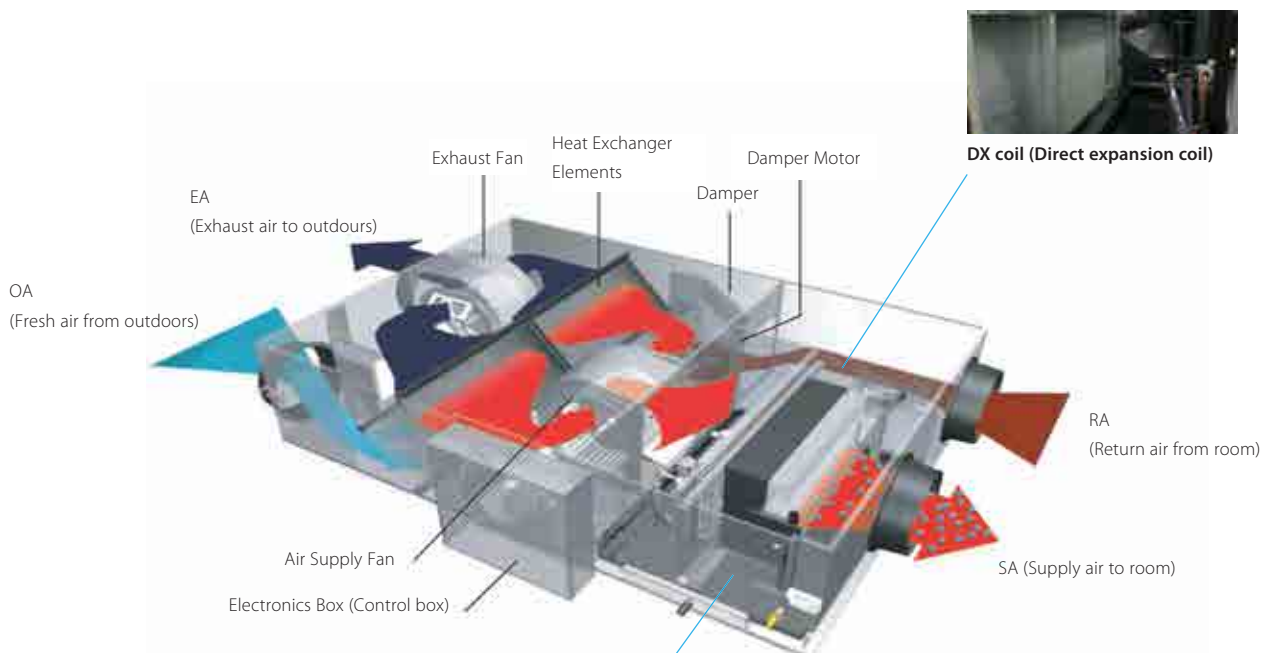

Humidifier element:

Utilizing the principle of capillary action, water is permeated throughout the humidifier element. The heated air from the DX coil passes through the humidifier and absorbs the moisture.

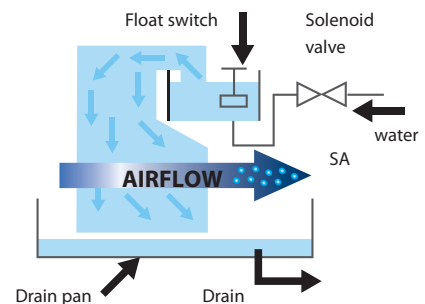

¹ VKM-GM example

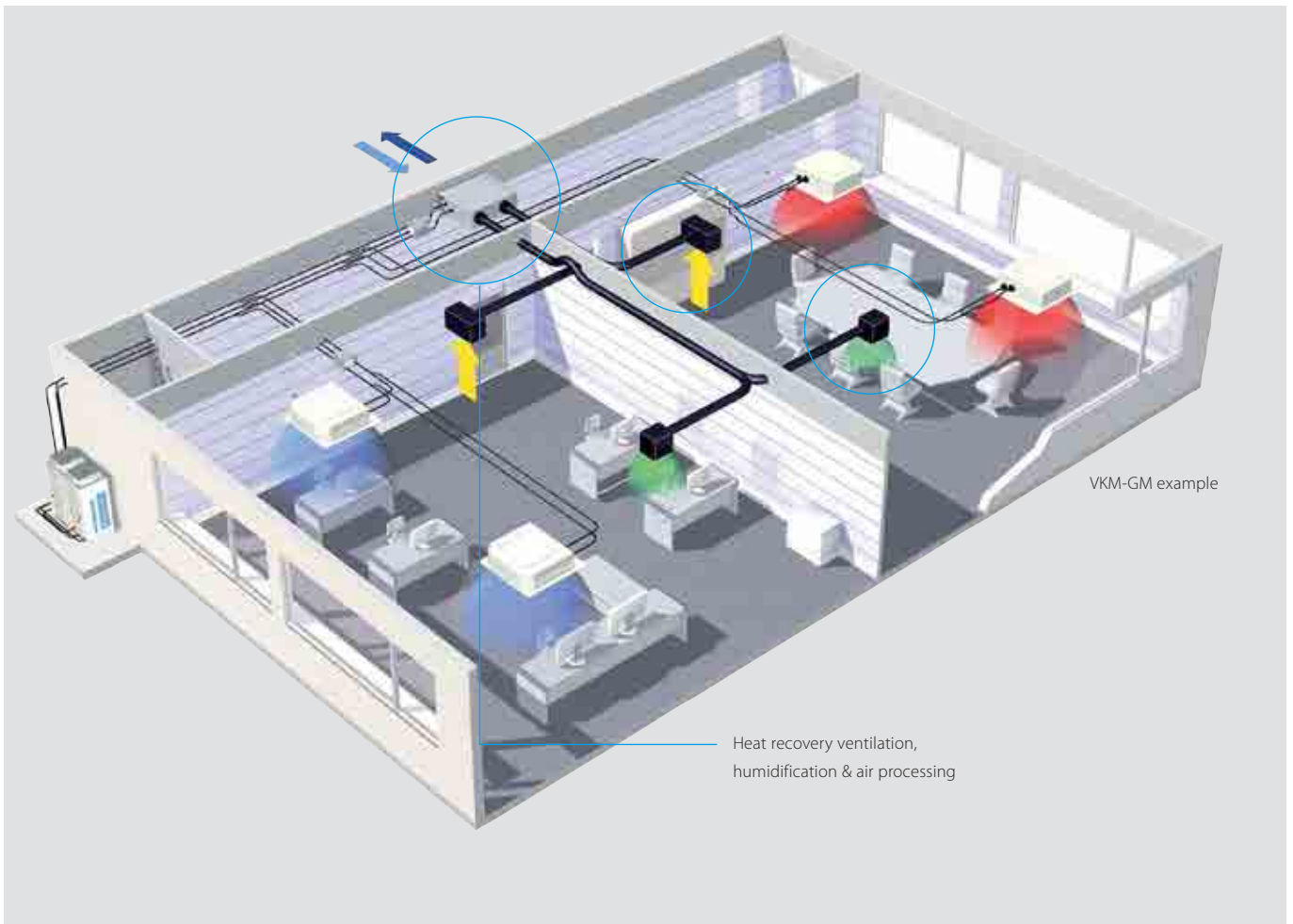

VKM-GM example

Heat recovery ventilation,
humidification & air processing

Ventilation				VKM	Heat reclaim ventilation and air processing			Heat reclaim ventilation, air processing and humidification		
					50GB	80GB	100GB	50GBM	80GBM	100GBM
Power input - 50Hz	Heat exchange mode	Nom.	Ultra high	kW	0.270	0.330	0.410	0.270	0.330	0.410
	Bypass mode	Nom.	Ultra high	kW	0.270	0.330	0.410	0.270	0.330	0.410
Fresh air conditioning load	Cooling			kW	4.71 / 1.91 / 3.5	7.46 / 2.96 / 5.6	9.12 / 3.52 / 7.0	4.71 / 1.91 / 3.5	7.46 / 2.96 / 5.6	9.12 / 3.52 / 7.0
	Heating			kW	5.58 / 2.38 / 3.5	8.79 / 3.79 / 5.6	10.69 / 4.39 / 7.0	5.58 / 2.38 / 3.5	8.79 / 3.79 / 5.6	10.69 / 4.39 / 7.0
Temperature exchange efficiency - 50Hz	Ultra high/High/Low			%	76/76/77.5	78/78/79	74/74/76.5	76/76/77.5	78/78/79	74/74/76.5
Enthalpy exchange efficiency - 50Hz	Cooling			%	64/64/67	66/66/68	62/62/66	64/64/67	66/66/68	62/62/66
	Heating			%	67/67/69	71/71/73	65/65/69	67/67/69	71/71/73	65/65/69
Operation mode	Heat exchange mode / Bypass mode / Fresh-up mode									
Heat exchange system	Air to air cross flow total heat (sensible + latent heat) exchange									
Heat exchange element	Specially processed non-flammable paper									
Humidifier	System				-			Natural evaporating type		
Dimensions	Unit	HeightxWidthxDepth		mm	387x1,764x832	387x1,764x1,214		387x1,764x832	387x1,764x1,214	
Weight	Unit			kg	94	110	112	100	119	123
Casing	Galvanised steel plate									
Fan-Air flow rate - 50Hz	Heat exchange mode	Ultra high		m ³ /h	500	750	950	500	750	950
	Bypass mode	Ultra high		m ³ /h	500	750	950	500	750	950
Fan-External static pressure - 50Hz	Ultra high			Pa	210		150	200	205	110
	High			Pa	170	160	100	150	155	70
	Low			Pa	140	110	70	120	105	60
Air filter	Multidirectional fibrous fleeces									
Sound pressure level - 50Hz	Heat exchange mode	Ultra high		dBA	39	41.5	41	38		40
	Bypass mode	Ultra high		dBA	40	41.5	41	39		41
Operation range	Around unit			°CDB	0°C~40°CDB, 80% RH or less					
	Supply air			°CDB	-15°C~40°CDB, 80% RH or less					
	Return air			°CDB	0°C~40°CDB, 80% RH or less					
	On coil temperature	Cooling	Max.		°CDB	-15				
		Heating	Min.		°CDB	43				
Refrigerant	Type / GWP				R-410A / 2.087,5					
Connection duct diameter					mm	200	250	200	250	
Piping connections	Liquid	OD		mm	6.35					
	Gas	OD		mm	12.7					
	Water supply			mm	-			6.4		
	Drain					PT3/4 external thread				
Power supply	Phase/Frequency/Voltage			Hz/V	1~/50/220-240					
Current	Maximum fuse amps (MFA)			A	15					

VKM50GB

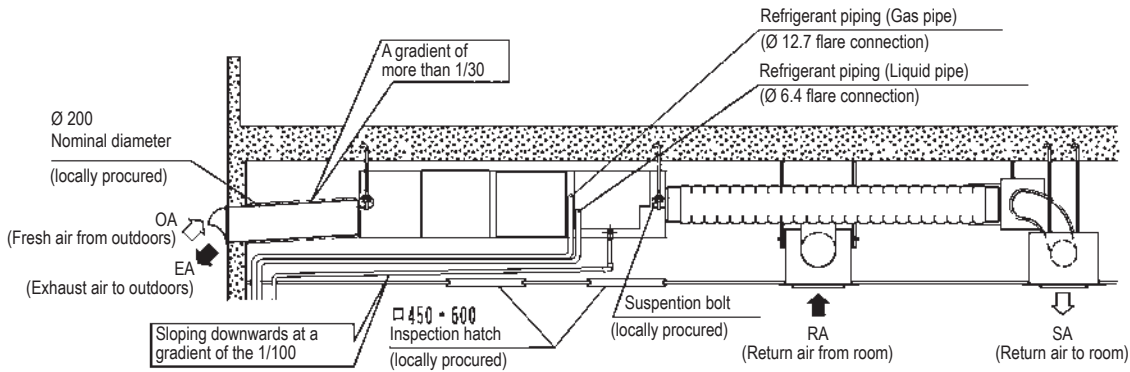
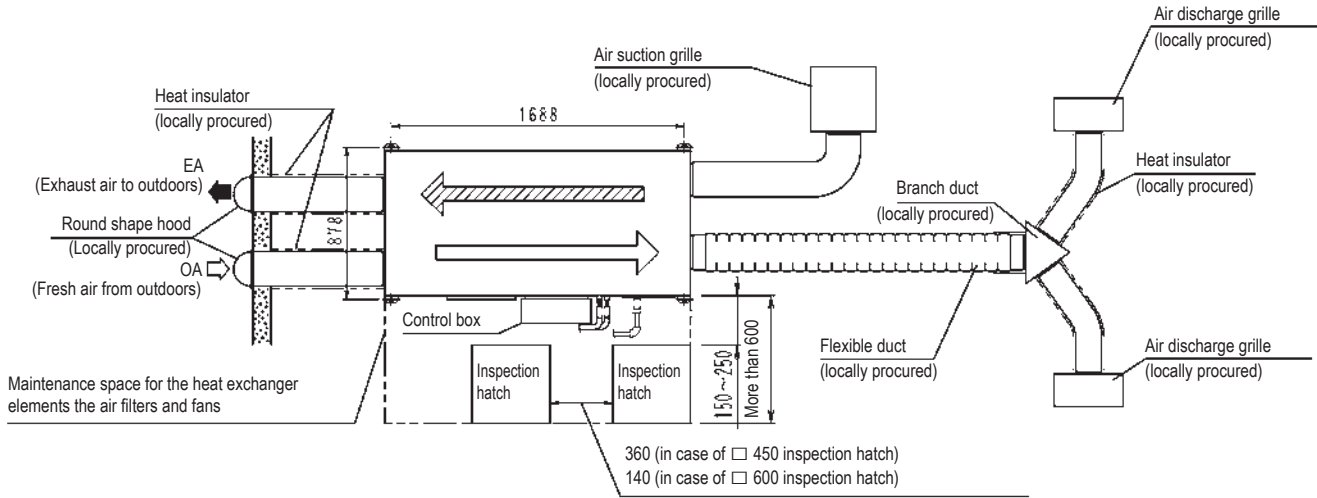

NOTES

1. Leave space for servicing the unit and include inspection hatch. (Always open a hole on the side of the control box so that the air filters, heat exchange elements, and fans can easily be inspected and serviced.)
2. Install the two outdoor ducts with down slope (slope of 1/30 or more) to prevent entry of rain water, also, provide insulation for three ducts (outdoor ducts and indoor supply air duct) to prevent dew condensation. (Material: glass wool of 25mm thick)
3. Do not turn the unit upside down.
4. Make sure to install drain piping, and insulate drain piping to prevent dew condensation.
5. Keep the drain pipe short and sloping downwards at a gradient of at least 1/100 to prevent air from forming.
6. Do not use a bent cap or a round hood as the outdoor hood if they might get rained on directly (we recommend using a deep hood) (optional accessory).
7. In areas where freezing may occur, always take steps to prevent the pipes from freezing.
8. Do not place something which shouldn't get wet at the below of this unit. The dew would fall at following case, where humidity is 80% more, or the exit of drain socket is choked up, or the air filter is very dirty.

VKM50GBM

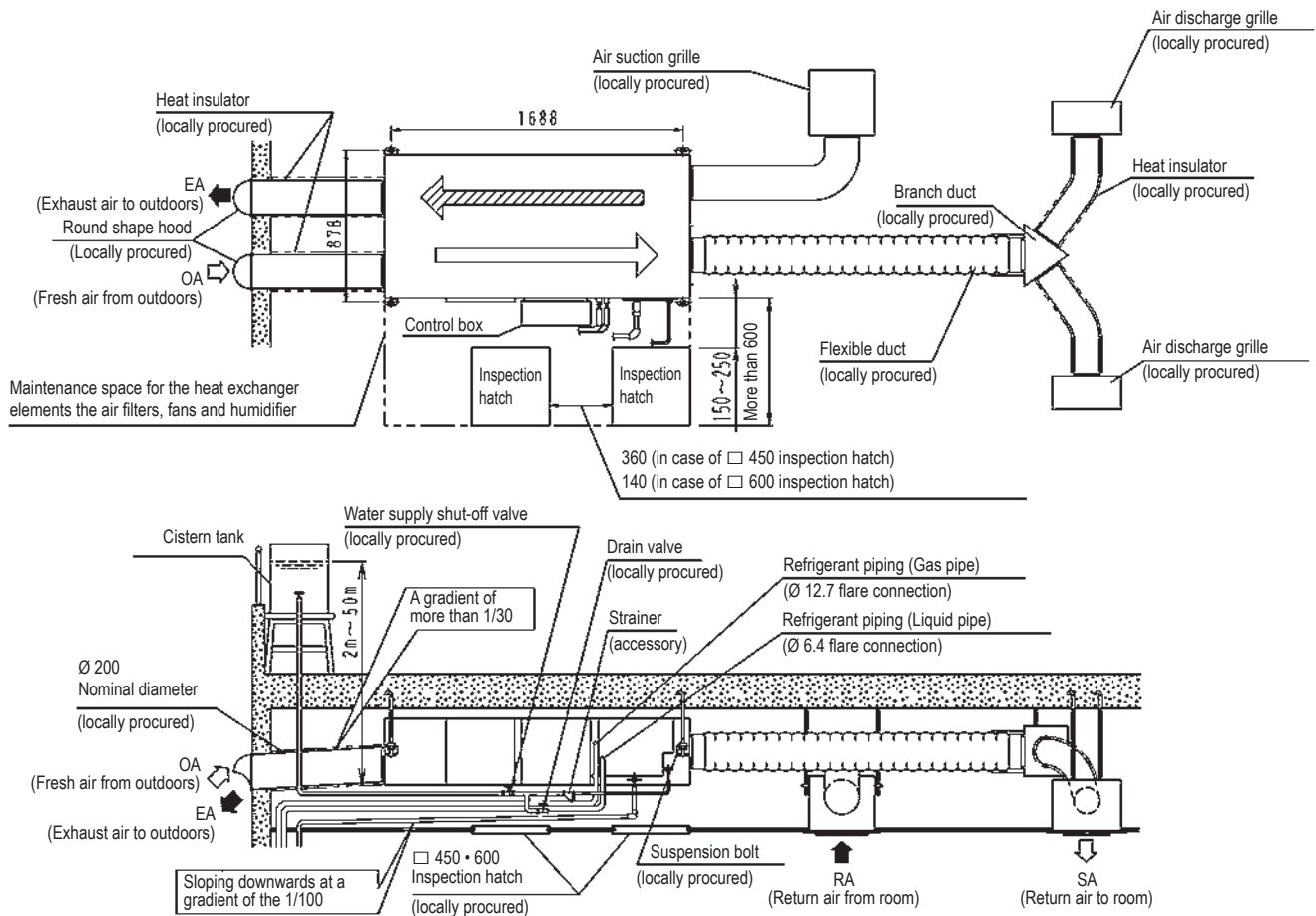

NOTES

1. Leave space for servicing the unit and include inspection hatch. (Always open a hole on the side of the control box so that the air filters, heat exchange elements, fans, and humidifier elements can easily be inspected and serviced.)
2. Install the two outdoor ducts with down slope (slope of 1/30 or more) to prevent entry of rain water. Also, provide insulation for three ducts (outdoor ducts and indoor supply air duct) to prevent dew condensation. (Material: glass wool of 25mm thick)
3. Do not turn the unit upside down.
4. Use city water or clean water.
Include water supply piping with strainer, a water supply shut-off valve, and a drain valve (both locally procured) somewhere along the water supply piping that can be reached from the inspection.
5. It is impossible to connect the water supply piping directly to public piping. Use a cistern tank (of the approved type), if you need to get your water supply from public piping.
6. Make sure the supply water 0.02MPa to 0.49MPa (0.2 kg/cm² to 5 kg/cm²).
7. Make sure the supply water is between 5 °C and 40 °C in temperature.
8. Insulate the water supply piping to prevent condensation from forming.
9. Make sure to install drain piping, and insulate drain piping to prevent dew condensation.
10. Keep the drain pipe short and sloping downwards at a gradient of at least 1/100 to prevent air from forming.
11. Install in a location where the air around the unit or taken into the humidifier will not drop below 0 °C.
12. Do not use a bent cap or a round hood as the outdoor hood if they might get rained on directly (we recommend using a deep hood) (optional accessory).
13. In areas where freezing may occur, always take steps to prevent the pipes from freezing.
14. Do not place something which shouldn't get wet at the below of this unit. The dew would fall at following case, where humidity is 80% more, or the exit of drain socket is choked up, or the air filter is very dirty.
15. Feed clean water. If the supply water is hard water, use a water softener because of short life.
Life of humidifying element is about 3 years (4,000 hours), under the supply water conditions of hardness: 150 mg/L. (Life of humidifying element is about 1 years (1500 hours), under the supply water conditions of hardness: 400 mg/L.)

3D083011

VKM80GB

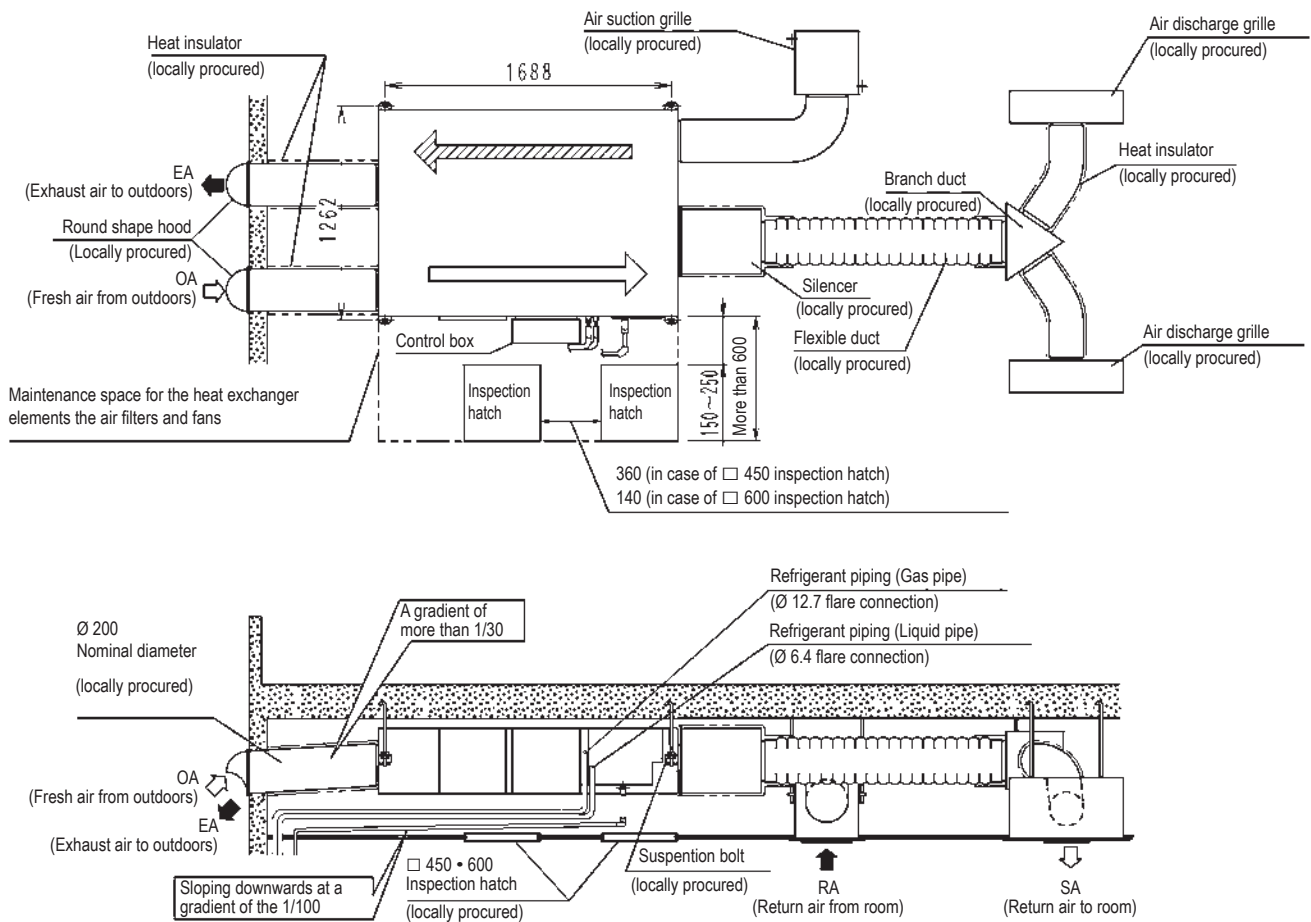

NOTES

1. Leave space for servicing the unit and include inspection hatch. (Always open a hole on the side of the control box so that the air filters, heat exchange elements, and fans can easily be inspected and serviced.)
2. Install the two outdoor ducts with down slope (slope of 1/30 or more) to prevent entry of rain water, also, provide insulation for three ducts (outdoor ducts and indoor supply air duct) to prevent dew condensation. (Material: glass wool of 25mm thick)
3. Do not turn the unit upside down.
4. Make sure to install drain piping, and insulate drain piping to prevent dew condensation.
5. Keep the drain pipe short and sloping downwards at a gradient of at least 1/100 to prevent air from forming.
6. Do not use a bent cap or a round hood as the outdoor hood if they might get rained on directly (we recommend using a deep hood) (optional accessory).
7. In areas where freezing may occur, always take steps to prevent the pipes from freezing.
8. Do not place something which shouldn't get wet at the below of this unit. The dew would fall at following case, where humidity is 80% more, or the exit of drain socket is choked up, or the air filter is very dirty.

VKM80GBM

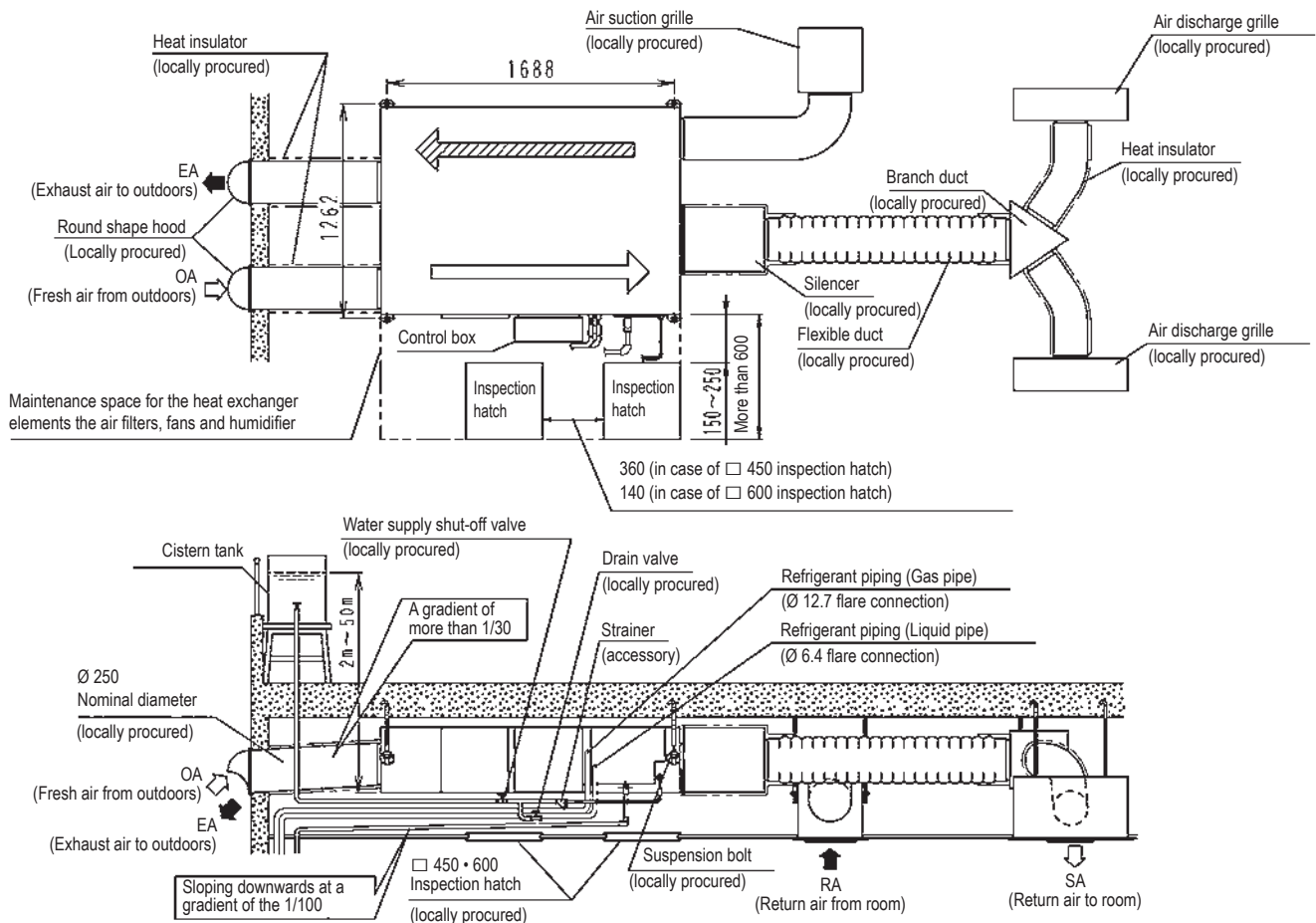

NOTES

1. Leave space for servicing the unit and include inspection hatch. (Always open a hole on the side of the control box so that the air filters, heat exchange elements, fans, and humidifier elements can easily be inspected and serviced.)
2. Install the two outdoor ducts with down slope (slope of 1/30 or more) to prevent entry of rain water. Also, provide insulation for three ducts (outdoor ducts and indoor supply air duct) to prevent dew condensation. (Material: glass wool of 25mm thick)
3. Do not turn the unit upside down.
4. Use city water or clean water.
Include water supply piping with strainer, a water supply shut-off valve, and a drain valve (both locally procured) somewhere along the water supply piping that can be reached from the inspection.
5. It is impossible to connect the water supply piping directly to public piping. Use a cistern tank (of the approved type), if you need to get your water supply from public piping.
6. Make sure the supply water 0.02MPa to 0.49MPa (0.2 kg/cm² to 5 kg/cm²).
7. Make sure the supply water is between 5 °C and 40 °C in temperature.
8. Insulate the water supply piping to prevent condensation from forming.
9. Make sure to install drain piping, and insulate drain piping to prevent dew condensation.
10. Keep the drain pipe short and sloping downwards at a gradient of at least 1/100 to prevent air from forming.
11. Install in a location where the air around the unit or taken into the humidifier will not drop below 0 °C.
12. Do not use a bent cap or a round hood as the outdoor hood if they might get rained on directly (we recommend using a deep hood) (optional accessory).
13. In areas where freezing may occur, always take steps to prevent the pipes from freezing.
14. Do not place something which shouldn't get wet at the below of this unit. The dew would fall at following case, where humidity is 80% more, or the exit of drain socket is choked up, or the air filter is very dirty.
15. Feed clean water. If the supply water is hard water, use a water softener because of short life.
Life of humidifying element is about 3 years (4,000 hours), under the supply water conditions of hardness: 150 mg/L. (Life of humidifying element is about 1 years (1500 hours), under the supply water conditions of hardness: 400 mg/L.)

3D083012

VKM100GB

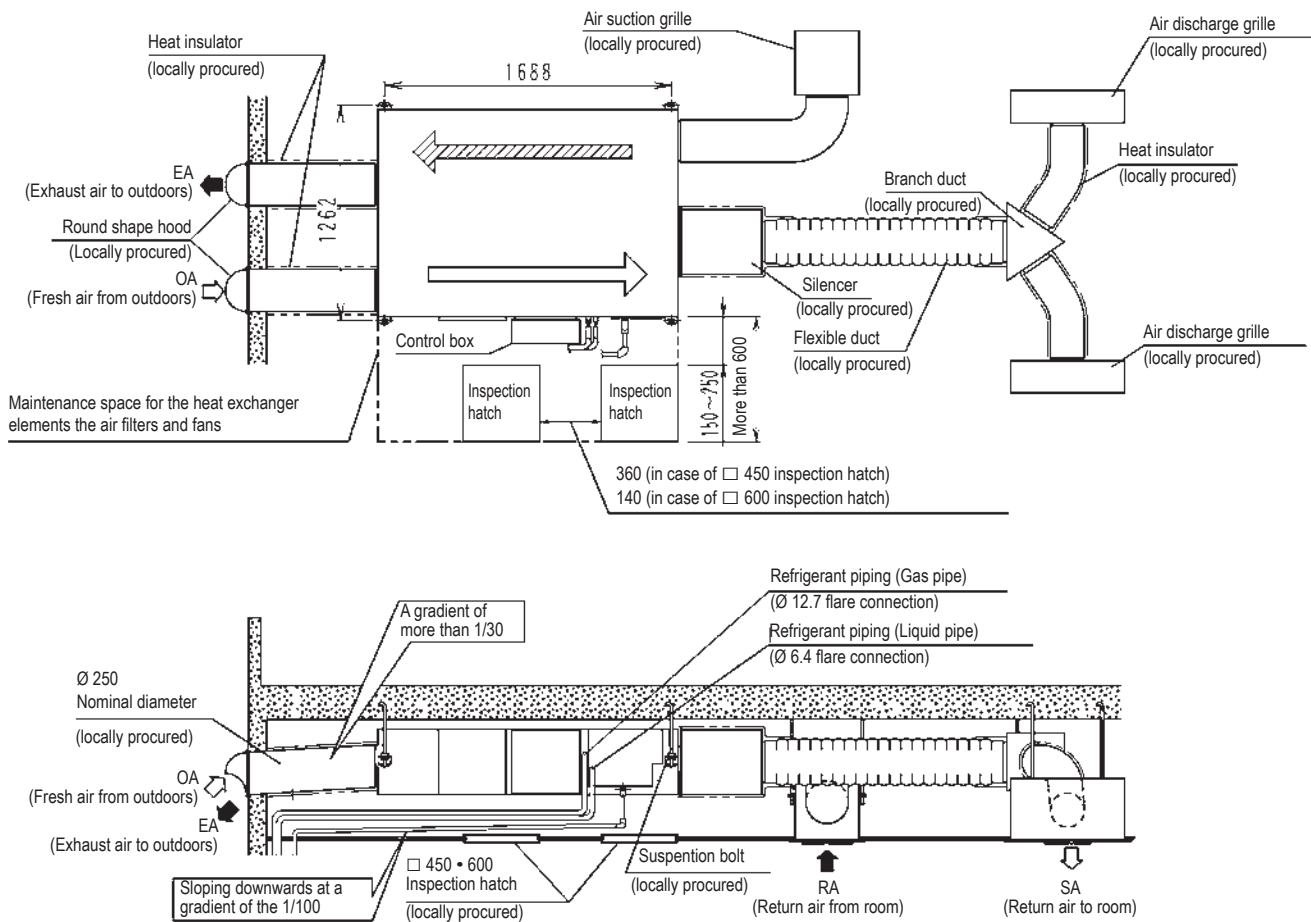

NOTES

1. Leave space for servicing the unit and include inspection hatch. (Always open a hole on the side of the control box so that the air filters, heat exchange elements, and fans can easily be inspected and serviced.)
2. Install the two outdoor ducts with down slope (slope of 1/30 or more) to prevent entry of rain water, also, provide insulation for three ducts (outdoor ducts and indoor supply air duct) to prevent dew condensation. (Material: glass wool of 25mm thick)
3. Do not turn the unit upside down.
4. Make sure to install drain piping, and insulate drain piping to prevent dew condensation.
5. Keep the drain pipe short and sloping downwards at a gradient of at least 1/100 to prevent air from forming.
6. Do not use a bent cap or a round hood as the outdoor hood if they might get rained on directly (we recommend using a deep hood) (optional accessory).
7. In areas where freezing may occur, always take steps to prevent the pipes from freezing.
8. Do not place something which shouldn't get wet at the below of this unit. The dew would fall at following case, where humidity is 80% more, or the exit of drain socket is choked up, or the air filter is very dirty.

VKM100GBM

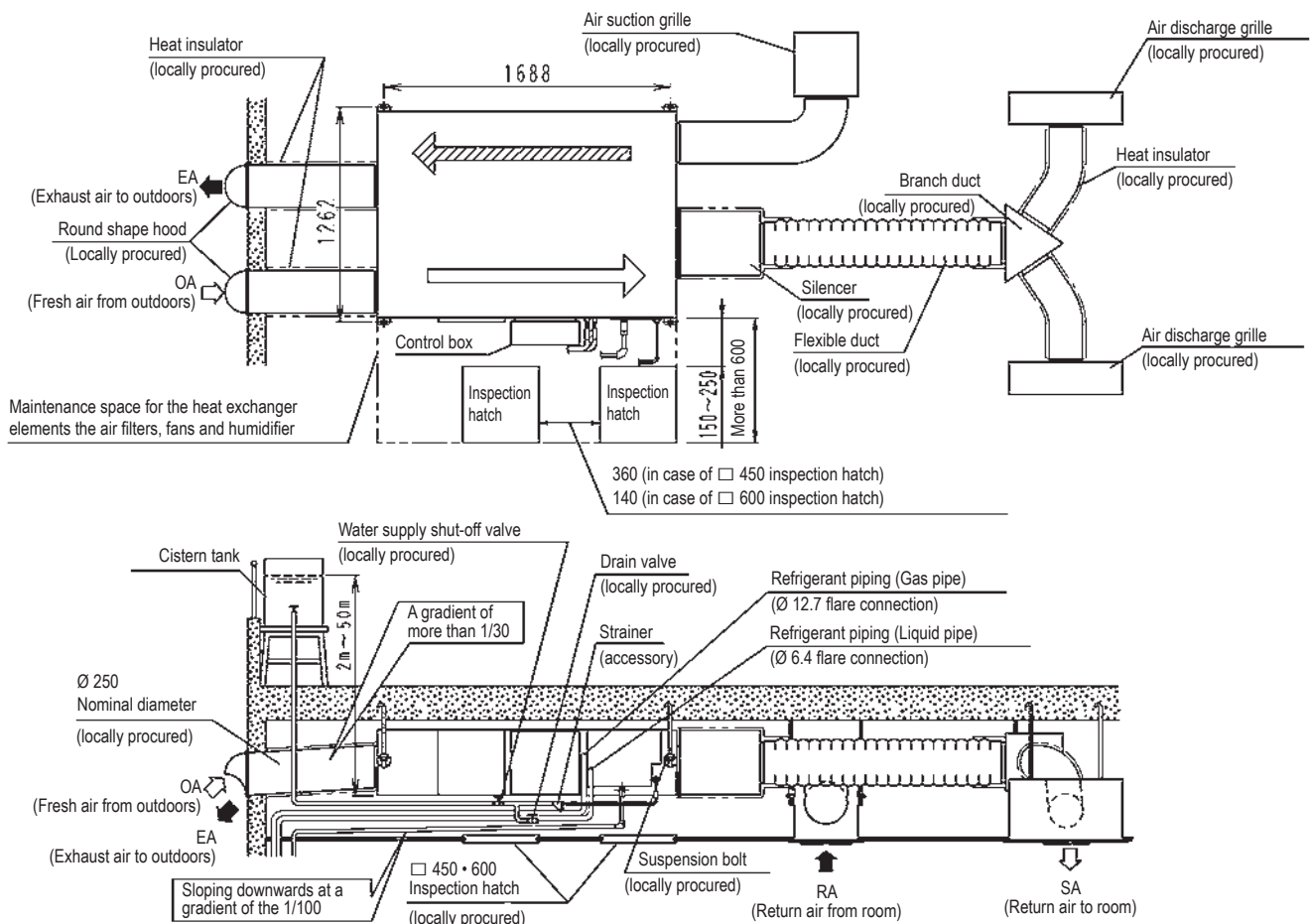

NOTES

1. Leave space for servicing the unit and include inspection hatch. (Always open a hole on the side of the control box so that the air filters, heat exchange elements, fans, and humidifier elements can easily be inspected and serviced.)
2. Install the two outdoor ducts with down slope (slope of 1/30 or more) to prevent entry of rain water. Also, provide insulation for three ducts (outdoor ducts and indoor supply air duct) to prevent dew condensation. (Material: glass wool of 25mm thick)
3. Do not turn the unit upside down.
4. Use city water or clean water.
Include water supply piping with strainer, a water supply shut-off valve, and a drain valve (both locally procured) somewhere along the water supply piping that can be reached from the inspection.
5. It is impossible to connect the water supply piping directly to public piping. Use a cistern tank (of the approved type), if you need to get your water supply from public piping.
6. Make sure the supply water 0.02MPa to 0.49MPa (0.2 kg/cm² to 5 kg/cm²).
7. Make sure the supply water is between 5 °C and 40 °C in temperature.
8. Insulate the water supply piping to prevent condensation from forming.
9. Make sure to install drain piping, and insulate drain piping to prevent dew condensation.
10. Keep the drain pipe short and sloping downwards at a gradient of at least 1/100 to prevent air from forming.
11. Install in a location where the air around the unit or taken into the humidifier will not drop below 0 °C.
12. Do not use a bent cap or a round hood as the outdoor hood if they might get rained on directly (we recommend using a deep hood) (optional accessory).
13. In areas where freezing may occur, always take steps to prevent the pipes from freezing.
14. Do not place something which shouldn't get wet at the below of this unit. The dew would fall at following case, where humidity is 80% more, or the exit of drain socket is choked up, or the air filter is very dirty.
15. Feed clean water. If the supply water is hard water, use a water softener because of short life.
Life of humidifying element is about 3 years (4,000 hours), under the supply water conditions of hardness: 150 mg/L. (Life of humidifying element is about 1 years (1500 hours), under the supply water conditions of hardness: 400 mg/L.)

3D083013

VKM50GB

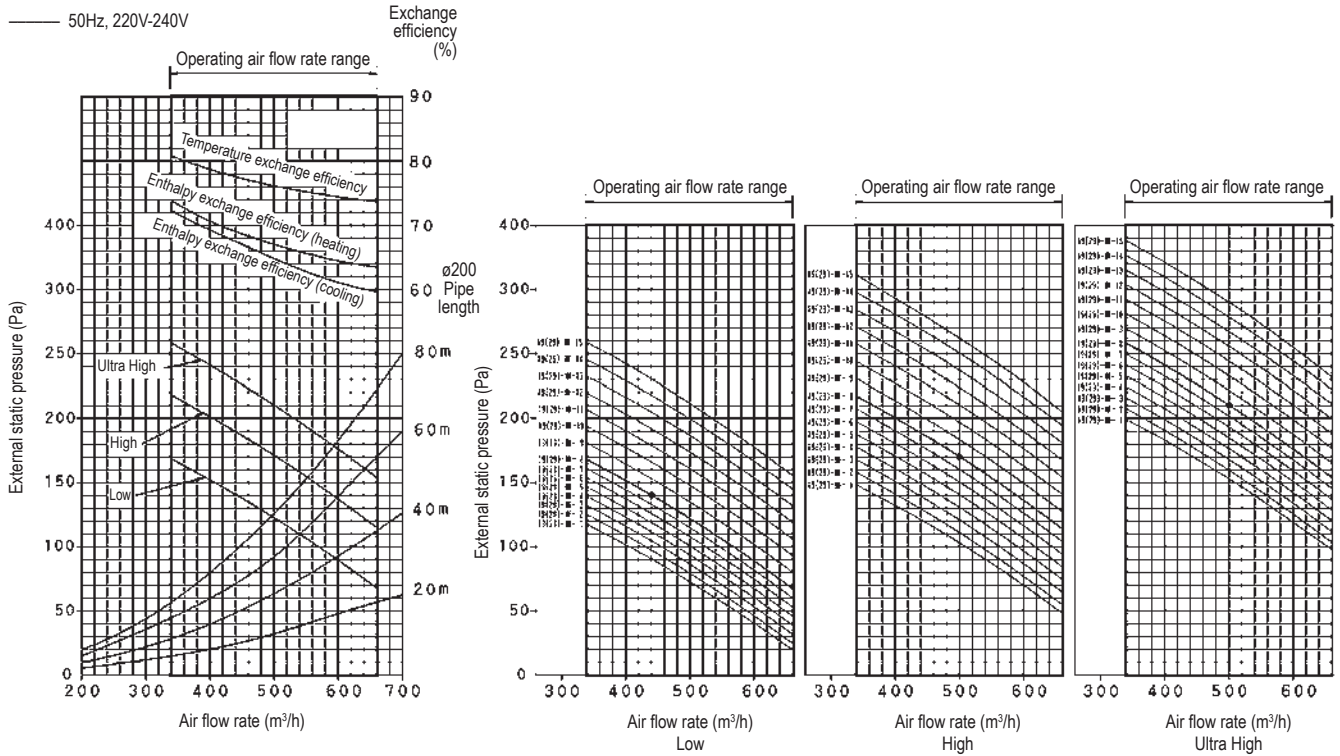

[Reading of Performance Characteristics]

- 1) For example: 19(29)-**■**-07
 Mode no. : 19(29)
 First code: **■** (Supply 「 2 」 Exhaust 「 3 」)
 Second code no. : 07
- 2) Rated point: ●
- 3) The characteristic of each tap becomes a setup of the characteristic of the same code number.

3D082904

VKM50GBM

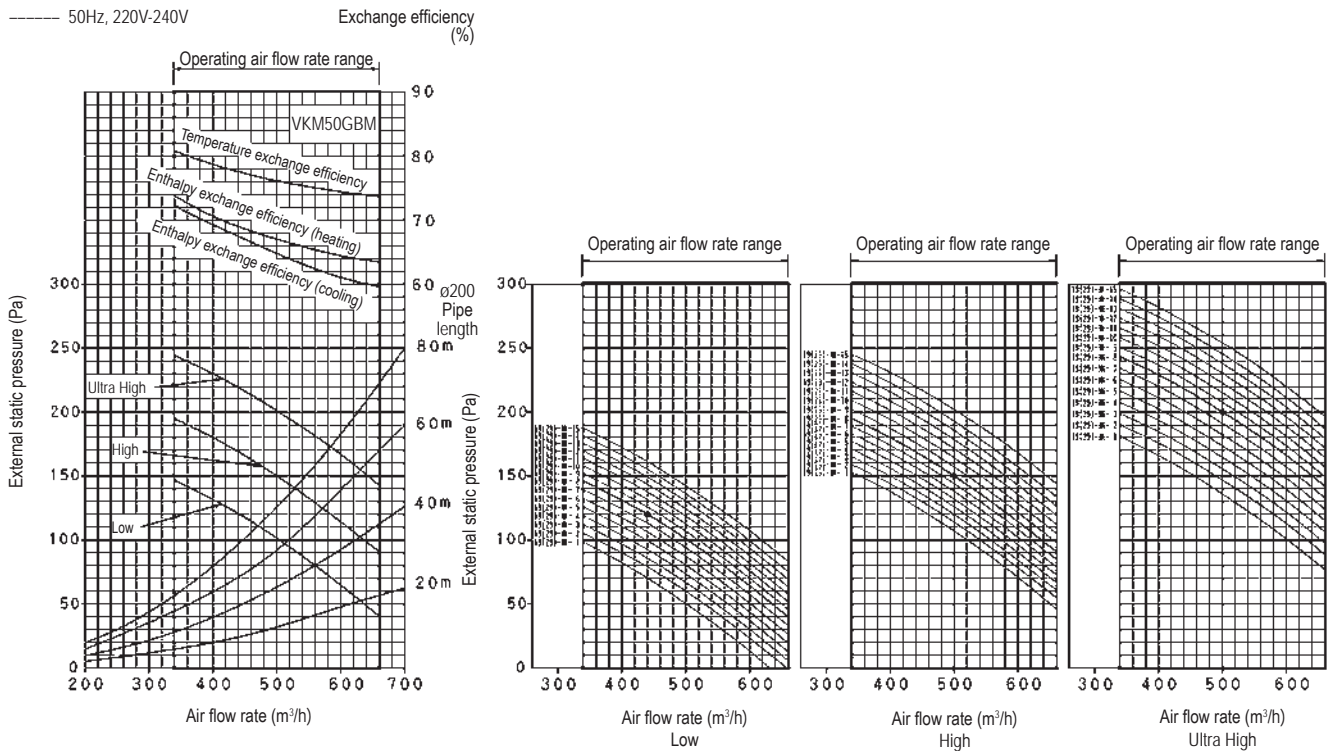

[Reading of Performance Characteristics]

- 1) For example: 19(29)-**■**-07
 Mode no. : 19(29)
 First code: **■** (Supply 「 2 」 Exhaust 「 3 」)
 Second code no. : 07
- 2) Rated point: ●
- 3) The characteristic of each tap becomes a setup of the characteristic of the same code number.

3D082901

VKM80GB

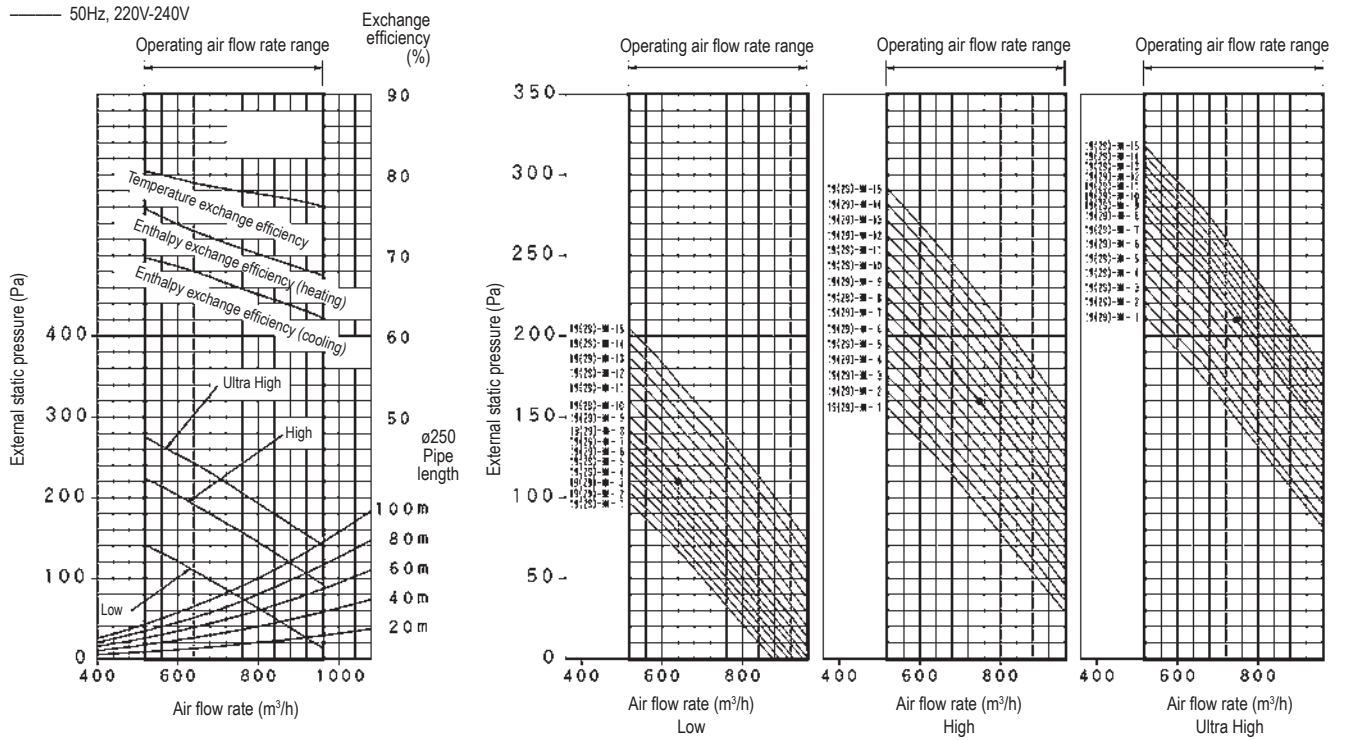

[Reading of Performance Characteristics]

- 1) For example: 19(29)-~~07~~
 Mode no. : 19(29)
 First code: ~~07~~ (Supply 「 2 」 Exhaust 「 3 」)
 Second code no. : 07
- 2) Rated point: ●
- 3) The characteristic of each tap becomes a setup of the characteristic of the same code number.

3D082905

VKM80GBM

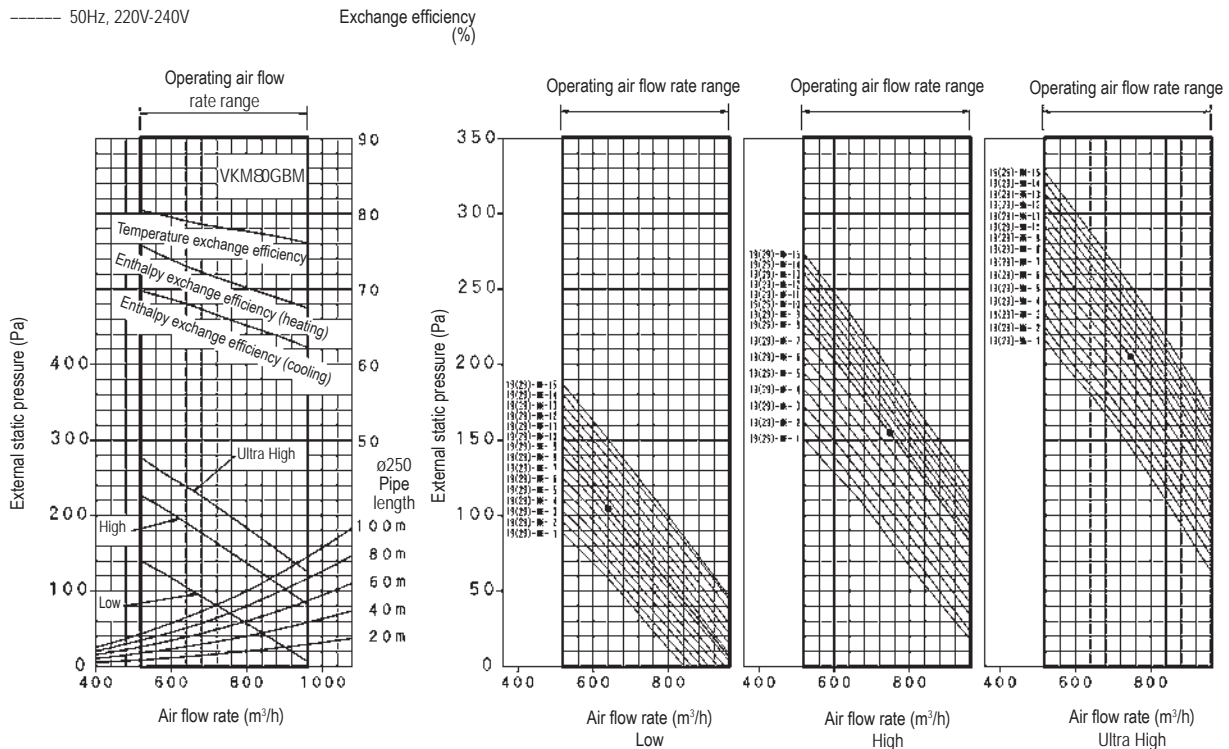

[Reading of Performance Characteristics]

- 1) For example: 19(29)-~~07~~
 Mode no. : 19(29)
 First code: ~~07~~ (Supply 「 2 」 Exhaust 「 3 」)
 Second code no. : 07
- 2) Rated point: ●
- 3) The characteristic of each tap becomes a setup of the characteristic of the same code number.

3D082902

VKM100GB

— 50Hz, 220V-240V

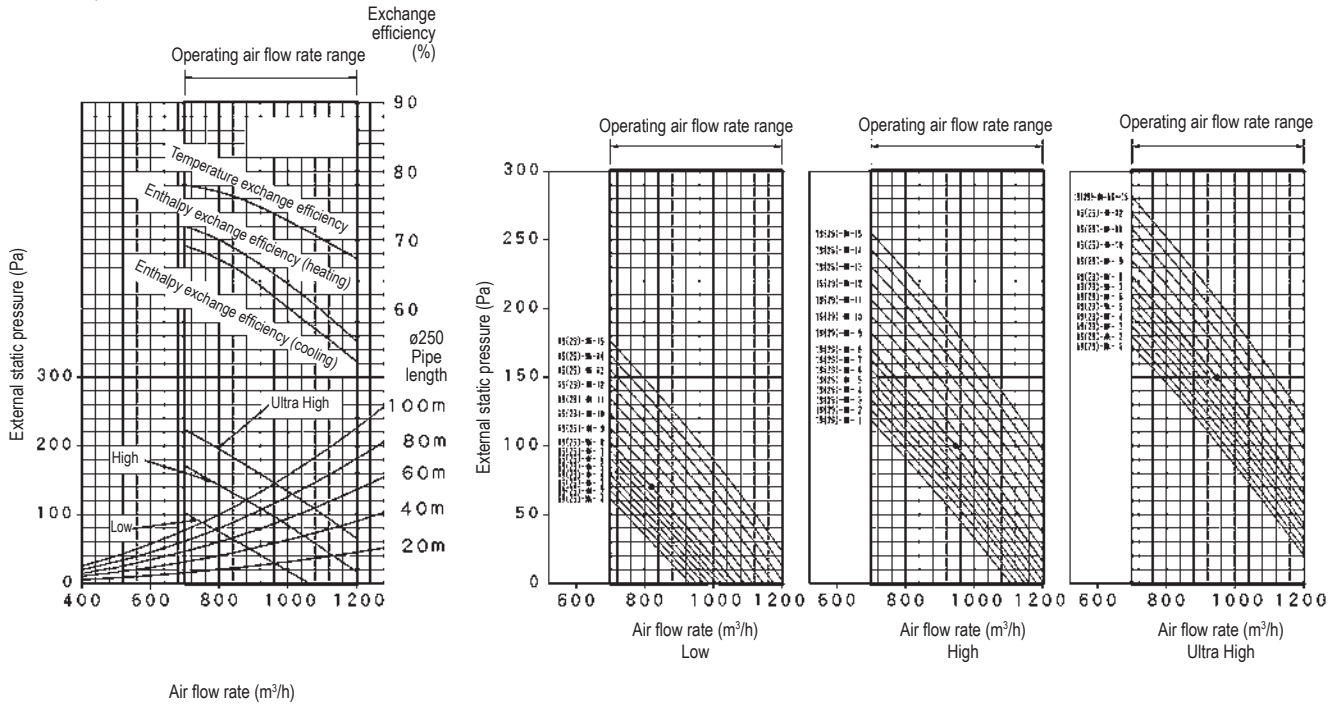

[Reading of Performance Characteristics]

- 1) For example: 19(29)-**■**-07
 Mode no. : 19(29)
 First code: **■** (Supply 「 2 」 Exhaust 「 3 」)
 Second code no. : 07
- 2) Rated point: ●
- 3) The characteristic of each tap becomes a setup of the characteristic of the same code number.

3D082906

VKM100GBM

— 50Hz, 220V-240V

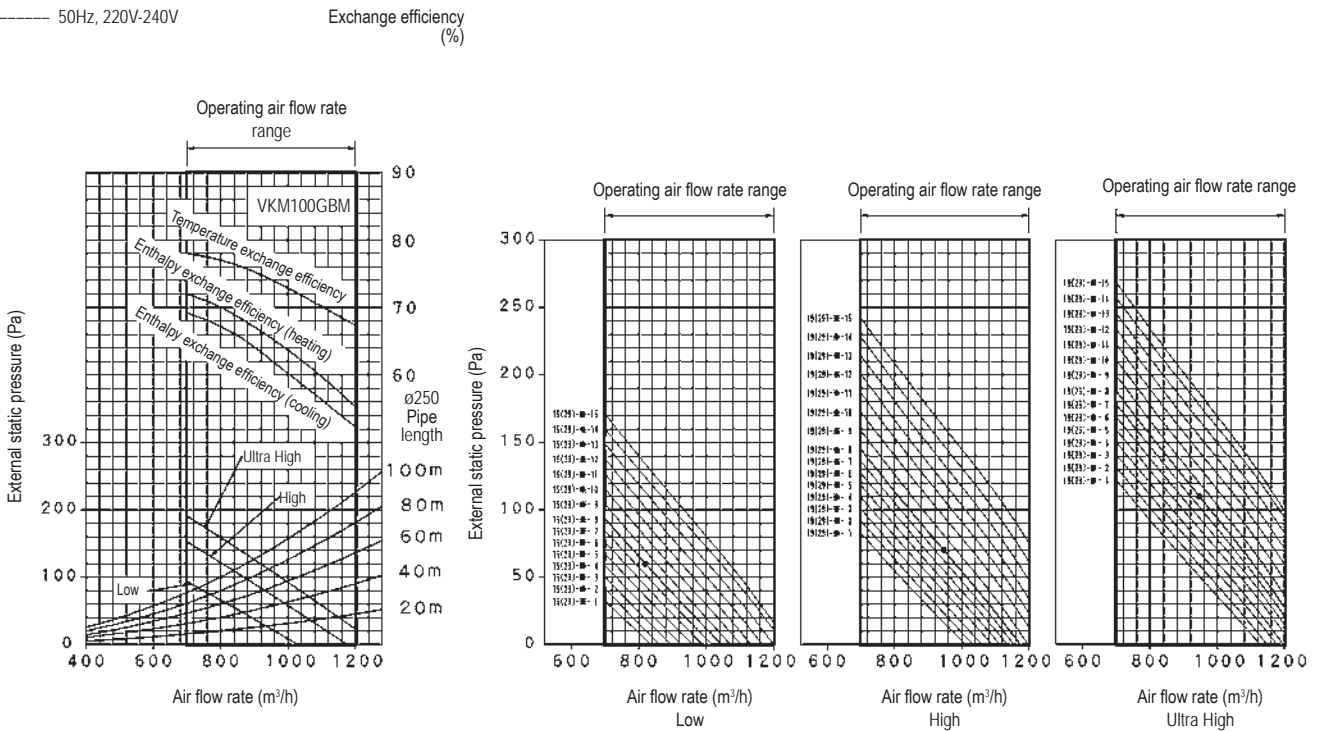

[Reading of Performance Characteristics]

- 1) For example: 19(29)-**■**-07
 Mode no. : 19(29)
 First code: **■** (Supply 「 2 」 Exhaust 「 3 」)
 Second code no. : 07
- 2) Rated point: ●
- 3) The characteristic of each tap becomes a setup of the characteristic of the same code number.

3D082903

Air handling applications

Wide range of air flows

For applications that require big volumes of treated fresh air (large atriums, banquet halls, etc) air handling units represent the ideal solution.

Daikin's wide range of air handling units treat air volumes from 500 m³/h up to 140,000 m³/h. The air handling unit can be designed to deliver

whatever air flow you require, via the specific dimensions of flow section available at the installation.

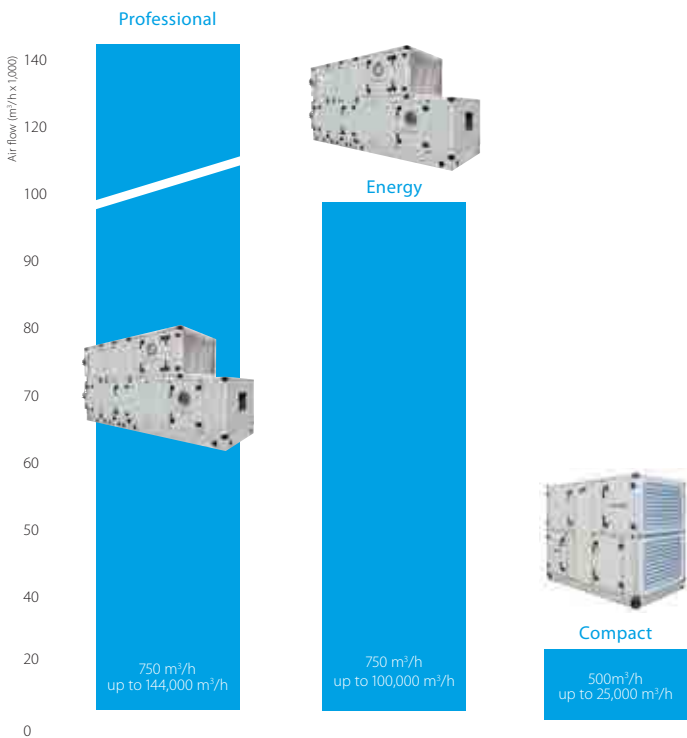

Professional

- › Pre-configured sizes
- › Tailored to the individual customer
- › Modular construction

Energy

- › High-end solution for optimised energy consumption
- › High efficiency components
- › Strong Return on Investment

NEW Compact

- › Pre-configured sizes
- › Plug & Play concept
- › EC Fan Technology
- › High Efficiency Heat Wheel
- › Compact Design

Daikin fresh air package - plug & play

The D-AHU Professional and Energy series provide a complete solution including unit control (EKEXV, EKEQ, DDC controller) factory mounted and configured, plug & play with our ERQ and VRV condensing units.

The easiest solution as you save time and only have one point of contact!

Return on investment

The air handling unit (AHU) is critical to an effective climate control system and the savings generated by our advanced designs and operating efficiencies guarantee a rapid return on the investment made. Our AHU Energy series has been designed to deliver exceptional performance thus driving down the energy consumed and so lowering energy bills. Taken over the expected 15-year life-span of the equipment, this will result in a substantial saving, especially in a time of ever increasing energy prices.

Pre-defined sizes

27 fixed sizes are available, optimized to reach the optimum combination between value for money and manufacturing standardisation. Daikin's section by section design means that units can be sized by 1cm increments and assembled on site, without welding, to suit the space constraints of the installation.

High efficiency components

All Daikin air handling units have been designed for optimum energy efficiency. Polyurethane or Mineral wool panels guarantee excellent thermal insulation performance. And the widest range of filters are provided to meet even the most strict demands.

Why use ERQ and VRV condensing units for connection to air handling units?

High Efficiency

Daikin heat pumps are renowned for their high energy efficiency. Integrating the AHU with a heat recovery system is even more effective since an office system can frequently be in cooling mode

while the outdoor air is too cold to be brought inside in an unconditioned state. In this case heat from the offices is merely transferred to heat up the cold incoming fresh air.

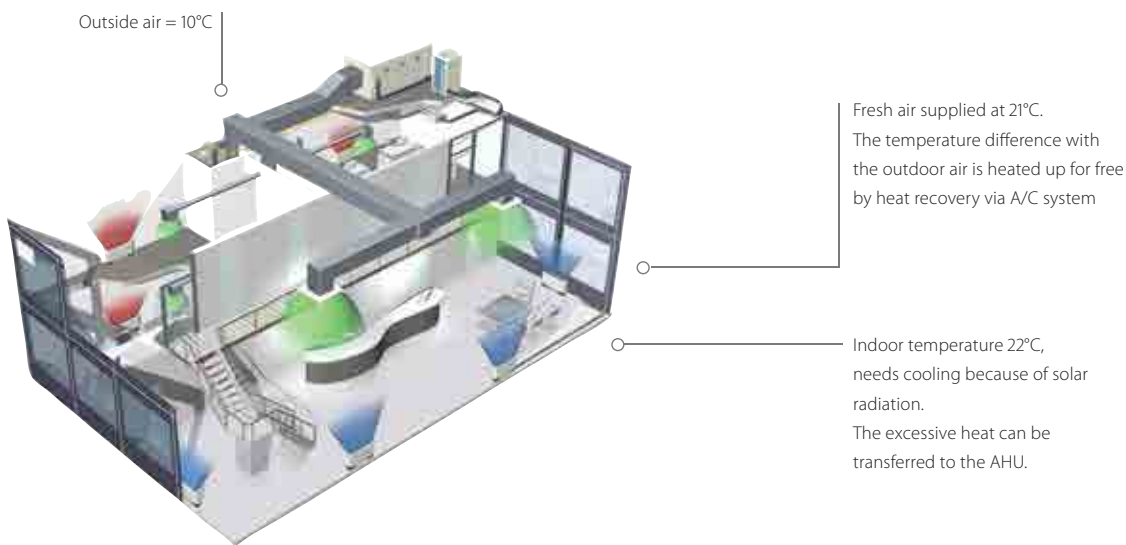

Fast response to changing loads resulting in high comfort levels

Daikin ERQ and VRV units respond rapidly to fluctuations in supply air temperature, resulting in a steady indoor temperature and resultant high comfort levels for the end user. The ultimate is the VRV range which improves comfort even more by offering continuous heating, also during defrost.

Easy Design and Installation

The system is easy to design and install since no additional water systems such as boilers, tanks and gas connections etc. are required. This also reduces both the total system investment and running cost.

Daikin Fresh air package

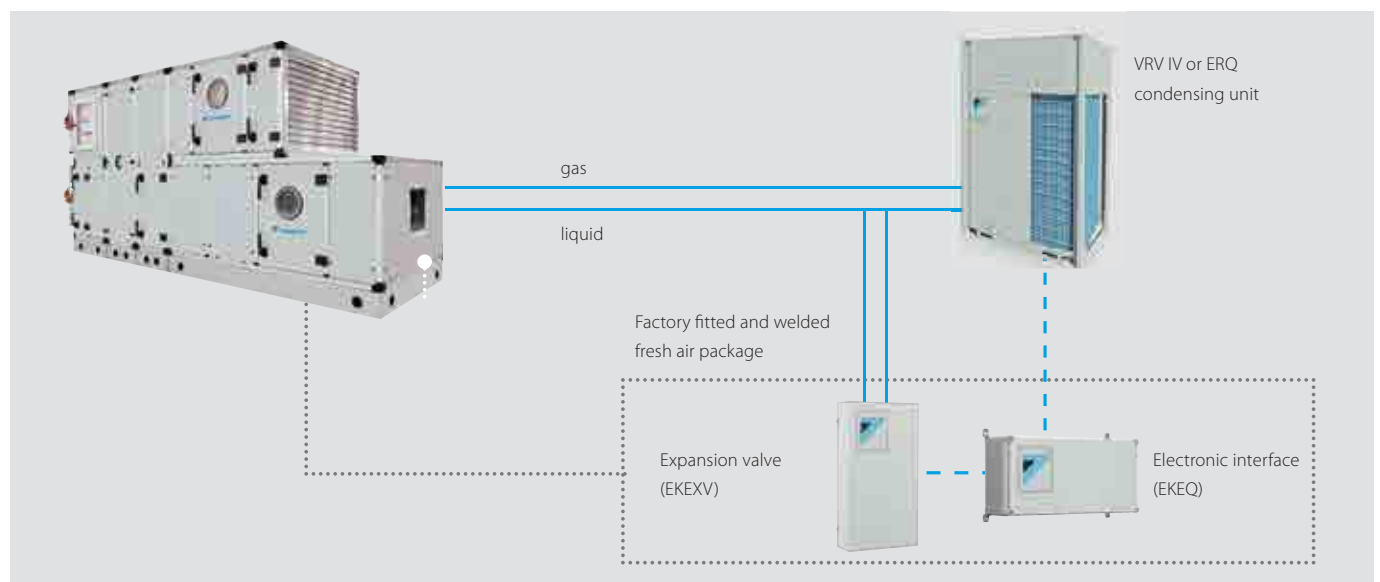

In order to maximize installation flexibility, 4 types of control systems are offered

Control w: Off the shelf control of air temperature (discharge temperature, suction temperature, room temperature) via any DDC controller using a proportional 0~10V algorithm for capacity control

Control x: Precise control of air temperature (discharge temperature, suction temperature, room temperature) requiring a preprogrammed DDC controller (for special applications) using a proportional 0~10V algorithm for capacity control

Control y: Control of refrigerant (Te/Tc) temperature via Daikin control (no DDC controller needed) with 3rd party thermostat (Daikin control for field settings and error indication)

Control z: Control of air temperature (suction temperature, room temperature) via Daikin control (no DDC controller needed)

Possibility W (Td/Tr control):

Air temperature control via DDC controller

Room temperature is controlled as a function of the air handling unit suction or discharge air (customer selection). The DDC controller is translating the temperature difference between set point and air suction temperature (or air discharge temperature or room temperature) into a proportional 0-10V signal which is transferred to the Daikin control box (EKEQFCBA). This voltage controls the compressor frequency.

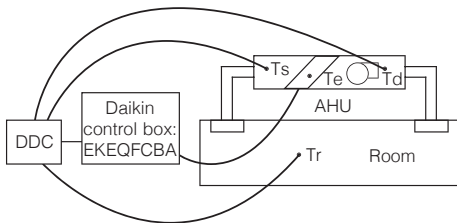

Possibility X (Td/Tr control):

Precise air temperature control via DDC controller

Room temperature is controlled as a function of the air handling unit suction or discharge air (customer selection). The DDC controller is translating the temperature difference between set point and air suction temperature (or air discharge temperature or room temperature) into a reference voltage (0-10V) which is transferred to the Daikin control box (EKEQFCBA). This reference voltage will be used as the main input value for the compressor frequency control.

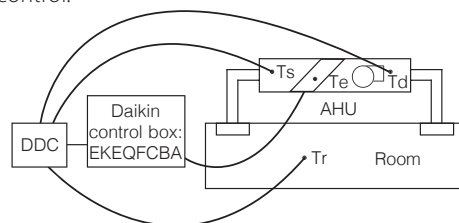

Possibility Y (Te/Tc control):

By fixed evaporating /condensing temperature

A fixed target evaporating temperature of between 3°C and 12°C can be set by the customer. In this case, room temperature is only indirectly controlled. The cooling load is determined from the actual evaporating temperature (i.e. load to the heat exchanger). A Daikin infrared remote control (BRC1D52 or BRC1E52A/B - optional) can be connected for error indication.

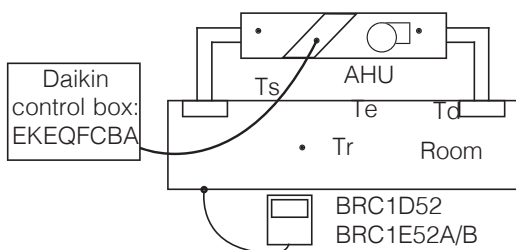

Possibility Z (Ts/Tr control):

Control your AHU just like a VRV indoor unit with 100% fresh air (BRC1D52 or BRC1E52A/B - optional)

Set point can be fixed via standard Daikin infrared remote control. Remote ON/OFF can be achieved by an optional adapter KRP4A51.

No external DDC controller should be connected. The cooling load is determined from the air suction temperature and set point on the Daikin controller.

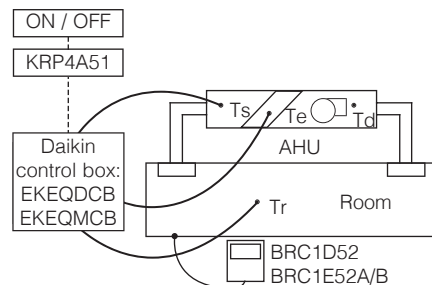

Ts = Air suction temperature Tr = Room temperature AHU = Air Handling Unit
Td = Air discharge temperature Te = Evaporating temperature DDC = Digital Display Controller

	Option kit	Features
Possibility w	EKEQFCBA	DDC controller is required temperature control using air suction or air discharge temperature
Possibility x		DDC and Microtech controller is required Precise Temperature control using air suction or air discharge temperature
Possibility y		Using fixed evaporating temperature, no set point can be set using remote control
Possibility z	EKEQDCB EKFQMCBA*	Using Daikin infrared remote control BRC1D52 or BRC1E52A/B Temperature control using air suction temperature

* EKEQMCB (for 'multi' application)

VRV - for larger capacities (from 8 to 54HP)

An advanced solution for both pair and multi application

- › Inverter controlled units
- › Heat recovery, heat pump
- › R-410A
- › Control of room temperature via Daikin control
- › Large range of expansion valve kits available
- › BRC1E52A/B is used to set the set point temperature (connected to the EKEQMCBA).
- › Connectable to all VRV heat recovery and heat pump systems



W, X, Y control for VRV IV heat pump

R*YQ8-20T

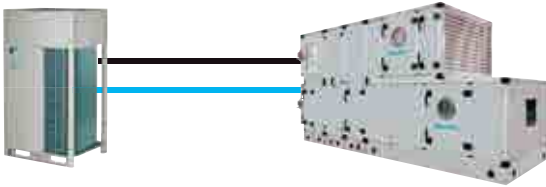

R*YQ12-54T

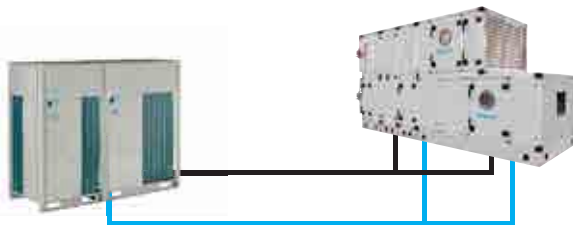

Z control for all VRV outdoor units

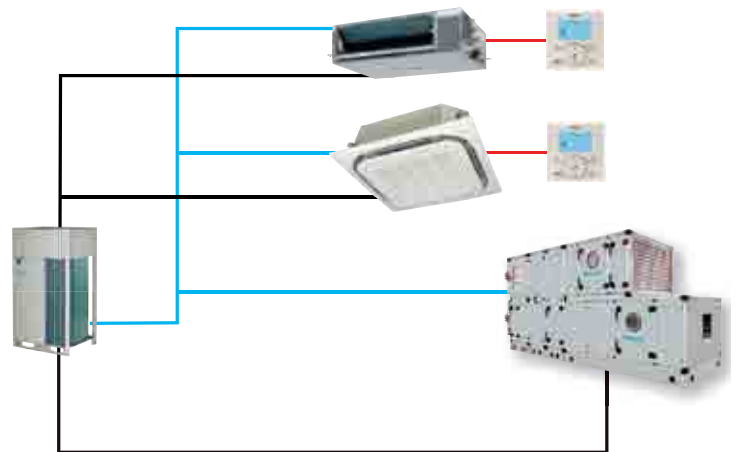

- Refrigerant piping
- F1-F2
- other communication

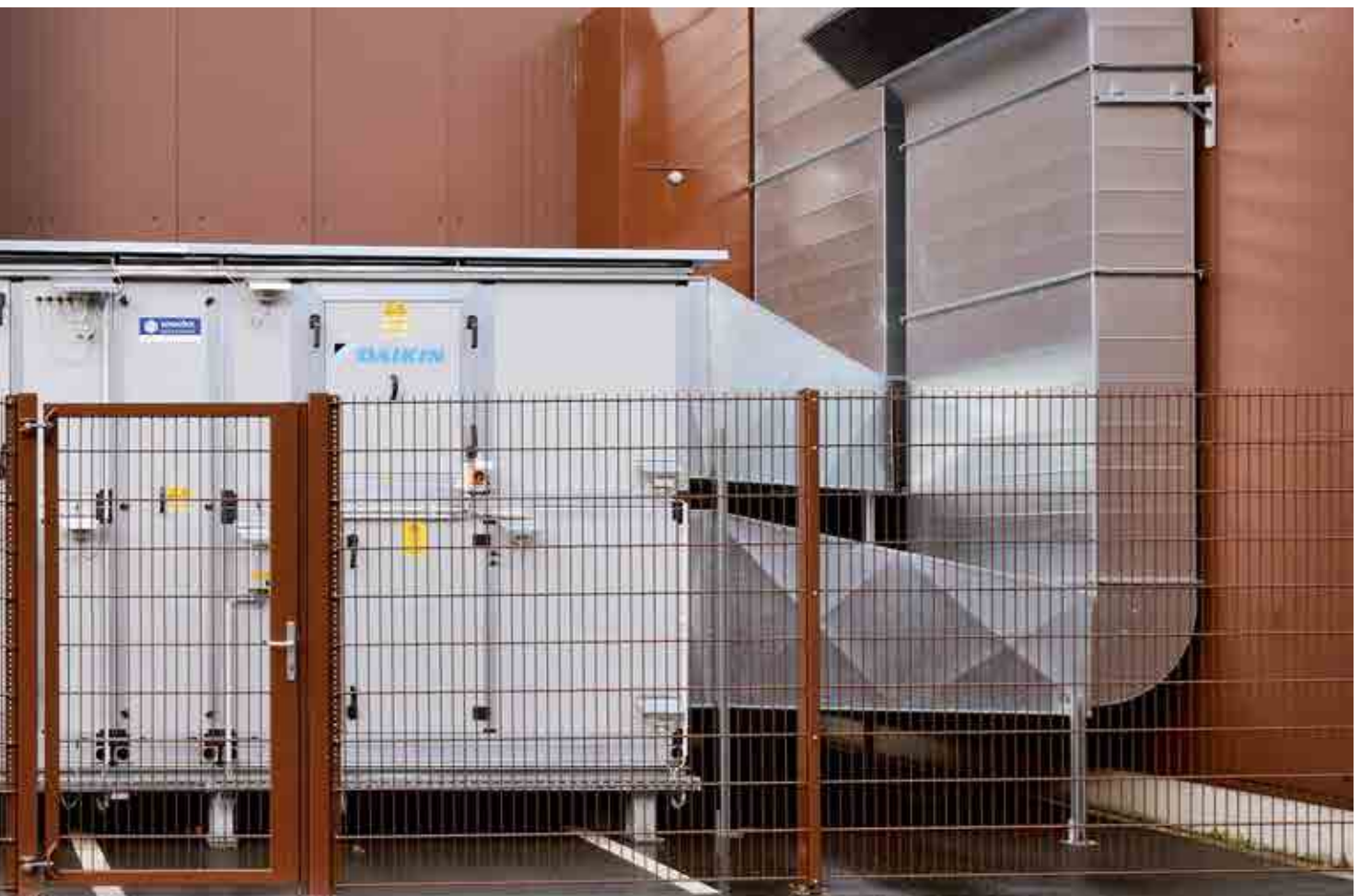

ERQ - for smaller capacities (from 100 to 250 class)

An basic fresh air solution for both pair application

- > Inverter controlled units
- > Heat pump
- > R-410A
- > Wide range of expansion valve kits available

The "Daikin Fresh Air Package" provides a complete Plug & Play Solution including AHU, ERQ or VRV Condensing Unit and all unit control (EKEQ, EKEX, DDC controller) factory mounted and configured. The easiest solution with only one point of contact.

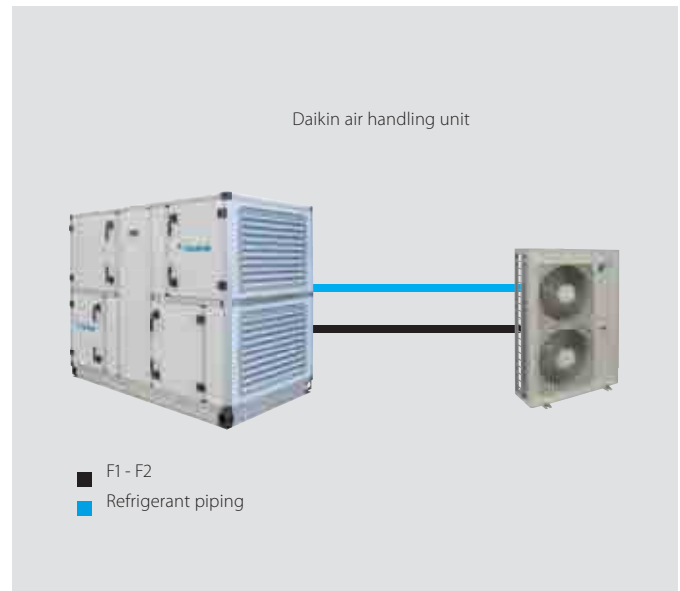

Ventilation				ERQ	100AV1	125AV1	140AV1
Capacity range				HP	4	5	6
Cooling capacity Nom.				kW	11.2	14.0	15.5
Heating capacity Nom.				kW	12.5	16.0	18.0
Power input	Cooling	Nom.	kW	2.81	3.51	4.53	
	Heating	Nom.	kW	2.74	3.86	4.57	
EER					3.99		3.42
COP					4.56	4.15	3.94
Dimensions	Unit	mm		1,345x900x320			
Weight	Unit	kg		120			
Fan-Air flow rate	Cooling	Nom.	m ³ /min			106	
	Heating	Nom.	m ³ /min	102			105
Sound power level	Cooling	Nom.	dBA	66	67	69	
Sound pressure level	Cooling	Nom.	dBA	50	51	53	
	Heating	Nom.	dBA	52	53	55	
Operation range	Cooling	Min./Max.	°CDB	-5/46			
	Heating	Min./Max.	°CWB	-20/15.5			
	On coil temperature	Heating Min. / Cooling Max.	°CDB	10 (1) / 35			
Refrigerant	Type / GWP			R-410A / 2.087,5			
	Charge			kg/ TCO ₂ Eq			
Piping connections	Liquid	OD	mm	9.52			
	Gas	OD	mm	15.9			19.1
	Drain	OD	mm	26x3			
Power supply	Phase/Frequency/Voltage		Hz/V	1N~/50/220-240			
Current	Maximum fuse amps (MFA)		A	32.0			

Ventilation				ERQ	125AW1	200AW1	250AW1
Capacity range				HP	5	8	10
Cooling capacity Nom.				kW	14.0	22.4	28.0
Heating capacity Nom.				kW	16.0	25.0	31.5
Power input	Cooling	Nom.	kW	3.52	5.22	7.42	
	Heating	Nom.	kW	4.00	5.56	7.70	
EER					3.98	4.29	3.77
COP					4.00	4.50	4.09
Dimensions	Unit	mm		1,680x635x765	1,680x930x765		
Weight	Unit	kg		159	187	240	
Fan-Air flow rate	Cooling	Nom.	m ³ /min	95	171	185	
	Heating	Nom.	m ³ /min	95	171	185	
Sound power level	Nom.	dBA		72	78		
Sound pressure level	Nom.	dBA		54	57	58	
Operation range	Cooling	Min./Max.	°CDB	-5/43			
	Heating	Min./Max.	°CWB	-20/15			
	On coil temperature	Heating Min. / Cooling Max.	°CDB	10 / 35			
Refrigerant	Type / GWP			R-410A / 2.087,5			
	Charge			kg/ TCO ₂ Eq			
Piping connections	Liquid	OD	mm	6.2/12.9	7.7/16.1	8.4/17.5	
	Gas	OD	mm	15.9	19.1	22.2	
	Drain	OD	mm	26x3			
Power supply	Phase/Frequency/Voltage		Hz/V	3N~/50/400			
Current	Maximum fuse amps (MFA)		A	16	25		

(1) If on coil temperature is lower, use pre-treatment of the air (heat wheel, ...) to raise on coil temperature

Integration of ERQ and VRV in third party air handling units

a wide range of expansion valve kits and control boxes

Combination table

		Control box			Expansion valve kit									
		EKEQDCBV3	EKEQFCBAV3	EKEQMCAV3	EKEXV50	EKEXV63	EKEXV80	EKEXV100	EKEXV125	EKEXV140	EKEXV200	EKEXV250	EKEXV400	EKEXV500
		Z control	W,X,Y control	Z control										
System A	1-phase	ERQ100	P	P	-	P	P	P	P	-	-	-	-	-
		ERQ125	P	P	-	P	P	P	P	P	-	-	-	-
		ERQ140	P	P	-	-	P	P	P	P	-	-	-	-
	3-phase	ERQ125	P	P	-	P	P	P	P	P	-	-	-	-
		ERQ200	P	P	-	-	-	P	P	P	P	P	-	-
	ERQ250	P	P	-	-	-	-	P	P	P	P	-	-	
System B	VRV III			n1	n1	n1	n1	n1	n1	n1	n1	n1	n1	n1
System B	VRV IV		1->3	n2	n2	n2	n2	n2	n2	n2	n2	n2	n2	n2

- P (pair application): combination depends on the capacity of the air handling unit
- n1 (multi application: combination of air handling units and VRV DX indoor units): to determine the quantity, refer to the engineering data book
- n2 (multi application: multiple air handling units, or the combination of air handling units and VRV DX indoor units): to determine the quantity, refer to the engineering data book
- Control box EKEQFA can be connected to some types of VRV IV outdoor units (with a maximum of 3 boxes per unit). Do not combine EKEQFA control boxes with VRV DX indoor units, RA indoor units or hydroboxes

Capacity table

Cooling

EKEXV Class	Allowed heat exchanger capacity (kW)	
	Minimum	Maximum
50	5,0	6,2
63	6,3	7,8
80	7,9	9,9
100	10,0	12,3
125	12,4	15,4
140	15,5	17,6
200	17,7	24,6
250	24,7	30,8
400	35,4	49,5
500	49,6	61,6

Saturated evaporating temperature: 6°C
Air temperature: 27°C DB / 19°C WB

Heating

EKEXV Class	Allowed heat exchanger capacity (kW)	
	Minimum	Maximum
50	5,6	7,0
63	7,1	8,8
80	8,9	11,1
100	11,2	13,8
125	13,9	17,3
140	17,4	19,8
200	19,9	27,7
250	27,8	34,7
400	39,8	55,0
500	55,1	69,3

Saturated condensing temperature: 46°C
Air temperature: 20°C DB

EKEXV - Expansion valve kit for air handling applications

Ventilation		EKEXV	50	63	80	100	125	140	200	250	400	500
Dimensions	Unit	mm	401x215x78									
Weight	Unit	kg	2,9									
Sound pressure level Nom.		dBA	45									
Operation range	On coil temperature	Heating Min. °CDB	10 (1)									
		Cooling Max. °CDB	35 (2)									
Refrigerant	Type / GWP		R-410A / 2.087,5									
Piping connections	Liquid OD	mm	6.35				9.52				12.7	15.9

(1) The temperature of the air entering the coil in heating mode can be reduced to -5°CDB. Contact your local dealer for more information. (2) 45% Relative humidity.

EKEQ - Control box for air handling applications

Ventilation		EKEQ	FCBA	DCB	MCBA
Application			See note	Pair	Multi
Outdoor unit			ERQ / VRV	ERQ	VRV
Dimensions	Unit	mm	132x400x200		
Weight	Unit	kg	3.9	3.6	
Power supply	Phase/Frequency/Voltage	Hz/V	1~/50/230		

The combination of EKEQFCBA and ERQ is in pair application. The EKEQFCBA can be connected to some type of VRV IV outdoor units with a maximum of 3 control boxes. The combination with DX indoor units, hydroboxes, RA outdoor units, ... is not allowed. Refer to the combination table drawing of the outdoor unit for details.



WIRED REMOTE CONTROL
BRC1E52A



INTELLIGENT
TOUCH MANAGER
DCM601A51





INFRARED REMOTE
CONTROLLER

Control Systems

Control Systems

Requirements tables per application	218
Individual control systems	
Wired / infrared remote controls	220

Centralised control systems	
Centralised remote control / Unified ON/OFF control / Schedule timer	222
DTA113B51	223
 intelligent Controller	223

Mini building management system	
 intelligent Manager	224

Standard protocol interfaces	
Modbus interface	226
KNX Interface	229
BACnet Interface	230
LonWorks Interface	231
Daikin configurator software	232

Options & Accessories

Remote monitoring and maintenance	
I-Net	234
Wireless room temperature sensor	236
Wired room temperature sensor	236
Other integration devices	237

Requirement tables per application

Daikin offers various control solution adapted to the requirements of even the most demanding commercial application.

- › Basic control solutions for those customers with few requirements and limited budget
- › Integrating control solutions for those customers that would like to integrate Daikin units into their existing BMS system
- › Advanced control solutions for those customers that expect Daikin to deliver a mini BMS solution, including advance energy management

Shop

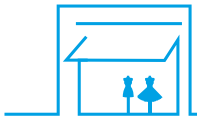

	Unit control		Integrating control			Advanced control	
	BRC1E52A/B 1 remote controller for 1 indoor unit (group)	RTD-20 1 gateway for 1 indoor unit (group)	RTD-Net 1 gateway for 1 indoor unit	KLIC-DI 1 gateway for 1 indoor unit	EKMBDXA 1 gateway for max. 64 indoor unit(s) (groups) & 10 outdoors	DCS601C51 1 iTC for 64 indoor unit(s) (groups)	DCM601A51 1 iTM for 64 indoor unit(s) (groups) (1)
Automatic control of A/C	●	●	●	●	●	●	●
Limited control possibilities for shop staff	●	●	●	●	●	●	●
Create zones within the shop		●				●	●
Interlock with eg. Alarm, PIR sensor		●					●
Integrate Daikin units into existing BMS via Modbus			●		●		
Integrate Daikin units into existing BMS via KNX				●			
Integrate Daikin units into existing BMS via HTTP						●	
Monitor energy consumption							●
Advanced energy management							●
Allows free cooling						●	●
Integrate Daikin products cross pillars into Daikin BMS							●
Integrate third party products into Daikin BMS							●
Web control standard available for control via local PC							●

(1) : 7 iTM plus adapters (DCM601A52) can be added to have 512 indoor groups and 80 outdoor (systems)

Hotel



	Unit control		Integrating control		Advanced control	
	BRC2/3E52C 1 remote controller for 1 indoor unit (group)	RTD-HO 1 gateway for 1 indoor unit (group)	RTD-Net 1 gateway for 1 indoor unit (group)	KLIC-DI 1 gateway for 1 indoor unit	DCS601C51 1 iTC for 64 indoor unit(s) (groups)	DCM601A51 1 iTM for 64 indoor unit(s) (groups) (1)
Hotel guest can control & monitor basic functionalities from his room	●	●	●	●	●	●
Limited control possibilities for hotel guests	●	●	●	●	●	●
Interlock with window contact	●	●				●
Interlock with key-card	●	●				●
Integrate Daikin units into existing BMS via Modbus			●			
Integrate Daikin units into existing BMS via KNX				●		
Integrate Daikin units into existing BMS via HTTP					●	
Monitor energy consumption						●
Advanced energy management						●
Integrate Daikin products cross pillars into Daikin BMS						●
Integrate third party products into Daikin BMS						●
Web control standard available for control via local PC						●

(1) : 7 iTM plus adapters (DCM601A52) can be added to have 512 indoor groups and 80 outdoor (systems)

Office



	Unit control	Integrating control			Advanced control		
	BRC1E52A/B	EKMBDXA	DMS504B51	DMS502A51 / DAM412B51	DCS302C51 / DST301B51	DCS601C51	DCM601A51
	1 remote controller for 1 indoor unit (group)	1 gateway for max. 64 indoor unit(s) (groups) & 10 outdoors	1 gateway for 64 indoor unit(s) (groups)	1 gateway for 128 indoor unit(s) (groups), 20 outdoors (2)	1 R/C for max. 64 groups, 128 indoor units, 10 outdoors	1 iTC for 64 indoor unit(s) (groups)	1 iTM for 64 indoor unit(s) (groups) (1)
Automatic control of A/C	●	●	●	●	● (3)	●	●
Centralised control for management		●	●	●	●	●	●
Local control for office workers	●	●	●	●	●	●	●
Limited control possibilities for office workers	●					●	●
Integrate Daikin units into existing BMS via Modbus		●					
Integrate Daikin units into existing BMS via KNX							
Integrate Daikin units into existing BMS via HTTP						●	
Integrate Daikin units into existing BMS via LonTalk			●				
Integrate Daikin units into existing BMS via BACnet				●			
Energy consumption read out	●						
Monitor energy consumption							●
Advanced energy management							●
Integrate Daikin products cross pillars into Daikin BMS							●
Integrate third party products into Daikin BMS							●
Web control standard available for control via local PC							●

(1) : 7 iTM plus adapters (DCM601A52) can be added to have 512 indoor groups and 80 outdoor (systems)

(2) : extension needed to go to 256 indoor unit(s) (groups), 40 outdoors

(3) : ON/OFF only

Technical cooling



	Unit	Integrating	Advanced
	DTA113B51	RTD-10	DCM601A51
	1 PCB for 4 indoor unit(s) (groups)	1 gateway for up to 8 indoor units (group)	1 iTM for 64 indoor unit(s) (groups) (1)
Automatic control of A/C	●	●	●
Back-up operation	●	●	●
Duty rotation	●	●	●
Limited control possibilities in the technical cooling room		●	●
If room temperature above max., then show alarm & start standby unit.		●	●
If an error occurs, an alarm will be shown.		●	●

(1) : 7 iTM plus adapters (DCM601A52) can be added to have 512 indoor groups and 80 outdoor (systems)

Individual control systems

BRC944B2*/BRC1D52

Wired remote control

┆ Schedule timer:

Five day actions can be set as follows:

- set point: unit is switched ON and normal operation is maintained
- OFF: unit is switched OFF¹
- limits: unit is switched ON and min./max. control (cf. limit operation for more details)

┆ Home leave (frost protection): during absence, the indoor temperature can be maintained at a certain level. This function can also switch the unit ON/OFF

┆ User friendly HRV function, thanks to the introduction of a button for ventilation mode and fan speed

┆ Constantly monitoring of the system for malfunctions in a total of 80 components

┆ Immediate display of fault location and condition

┆ Reduction of maintenance time and costs



BRC1D52



BRC944B2

Display

┆ Operating mode¹

┆ Heat Recovery Ventilation (HRV) in operation

┆ Cool / heat changeover control

┆ Centralised control indication

┆ Group control indication

┆ Set temperature¹

┆ Air flow direction¹

┆ Programmed time

┆ Inspection test / operation

┆ Fan speed¹

┆ Clean air filter

┆ Defrost / hot start

┆ Malfunction

¹ Only functions marked with '1' are available on BRC944B2

ARC4*/BRC4*/BRC7*

Infrared remote control

Operation buttons: ON / OFF, timer mode start / stop, timer mode on / off, programme time, temperature setting, air flow direction (1), operating mode, fan speed control, filter sign reset (2), inspection (2) / test indication (2)

Display: Operating mode, battery change, set temperature, air flow direction (1), programmed time, fan speed, inspection / test operation (2)

1. Not applicable for FXDQ, FXSQ, FXNQ, FBDQ, FDXS, FBQ

2. For FX** units only

3. For all features of the remote control, refer to the operation manual



ARC466A1



BRC4*/BRC7*

BRC2E52A / BRC3E52A

Simplified wired remote control developed for hotel applications

┆ Symbol driven interface for intuitive control

┆ Functions restricted to basic customer needs

┆ Contemporary design

┆ Energy saving thanks key card, window contact integration and set point limitation

┆ Flexible setback function ensures room temperature remains within comfortable limits to ensure guest comfort

┆ Flat backpanel for easy installation

┆ Easy commissioning: intuitive interface for advanced menu settings

┆ 2 versions available:

- Heat pump type: temperature, fan speed, ON/OFF
- Heat recovery type: temperature, mode, fan speed, ON/OFF

┆ Replaces existing BRC2C51 & BRC3A61





User friendly remote control with contemporary design

BRC1E52A/B



Graphical display of indicative electricity consumption
(Function available in combination with FCQG and FCGHQ)

A series of energy saving functions that can be individually selected

- › Temperature range limit
- › Setback function
- › Presence & floor sensor connection (available on new round flow cassette)
- › kWh indication
- › Set temperature auto reset
- › Off timer

Temperature range limit avoids excessive heating or cooling

Save energy by constraining the lower temperature limit in cooling and upper temperature limit in heating mode.

note : Also available in auto cooling/heating change over mode.

kWh indication keeps track of your consumption

The kWh indication shows an indicative electricity consumption of the last day/month/year.

Other functions

- › Up to 3 independent schedules can be set, so the user can easily change the schedule himself throughout the year (e.g. Summer, winter, mid-season)
- › Possibility to individually restrict menu functions
Easy to use: all main functions directly accessible
- › Easy setup: clear graphical user interface for advanced menu settings
- › Real time clock with auto update to daylight saving time
- › Built-in backup power: when a power failure occurs all settings remain stored up to 48 hours
- › Supports multiple languages
English, German, Dutch, Spanish, Italian, Portuguese, French, Greek, Russian, Turkish, Polish (BRC1E52A)
English, German, Czech, Croatian, Hungarian, Romanian, Slovenian, Bulgarian, Slovak, Serbian, Albanian (BRC1E52B)

Centralised control systems

Centralised control of the Sky Air and VRV system can be achieved via 3 user friendly compact. These controls may be used independently or in combination with 1 group = several (up to 16) indoor units in combination and 1 zone = several groups in combination.

A centralised remote control is ideal for use in tenanted commercial buildings subject to random occupation, enabling indoor units to be classified in groups per tenant (zoning).

The schedule timer programmes the schedule and operation conditions for each tenant and the control can easily be reset according to varying requirements.

DCS302C51

Centralised remote control



Providing individual control of 64 groups (zones) of indoor units.

- › a maximum of 64 groups (128 indoor units, max. 10 outdoor units) can be controlled
- › a maximum of 128 groups (128 indoor units, max. 10 outdoor units) can be controlled via 2 centralised remote controls in separate locations
- › zone control
- › group control
- › malfunction code display
- › maximum wiring length of 1,000m (total: 2,000m)
- › air flow direction and air flow rate of HRV can be controlled
- › expanded timer function

DCS301B51

Unified ON/OFF control



Providing simultaneous and individual control of 16 groups of indoor units.

- › a maximum of 16 groups (128 indoor units) can be controlled
- › 2 remote controls in separate locations can be used
- › operating status indication (normal operation, alarm)
- › centralised control indication
- › maximum wiring length of 1,000m (total: 2,000m)

DST301B51

Schedule timer



Enabling 64 groups to be programmed.

- › a maximum of 128 indoor units can be controlled
- › 8 types of weekly schedule
- › a maximum of 48 hours back up power supply
- › a maximum wiring length of 1,000m (total: 2,000m)

DTA113B51

Basic solution for control of Sky Air and VRV

- › Rotation function
- › Backup operation function.

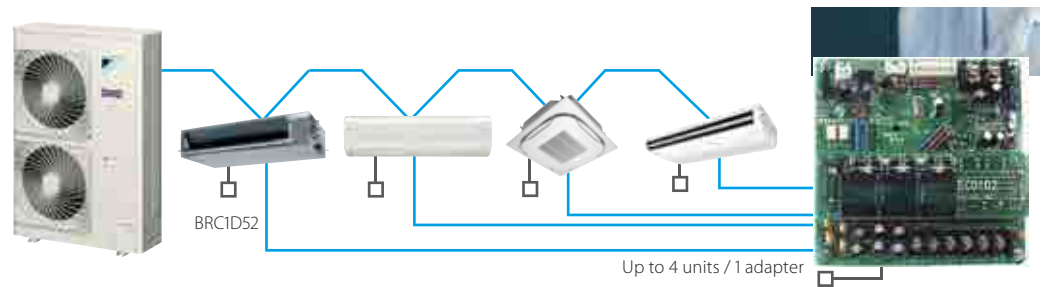

intelligent Controller

DCS601C51

Detailed & easy monitoring and operation of VRV systems (max. 64 indoor units groups).

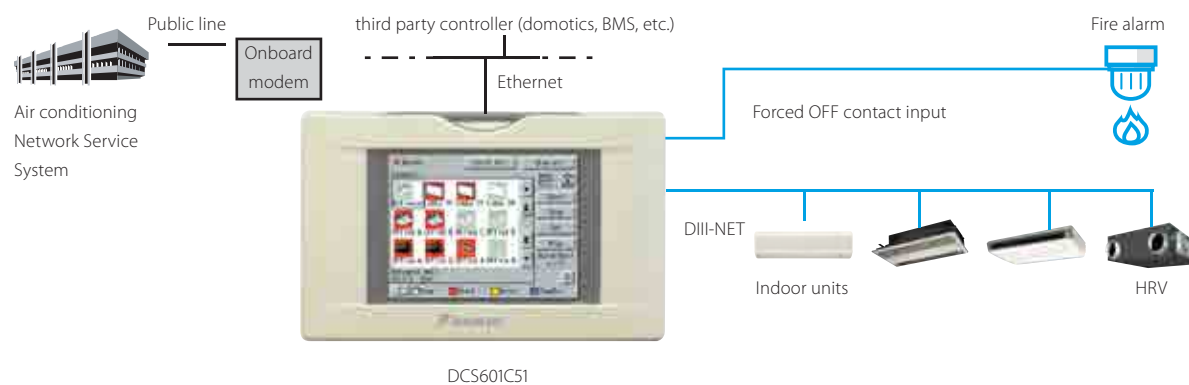

Languages

- › English
- › French
- › German
- › Italian
- › Spanish
- › Dutch
- › Portuguese

System layout

- › Up to 64 indoor units can be controlled
- › Touch panel (full colour LCD via icon display)

Management

- › Enhanced history function

Control

- › Individual control (set point, start/stop, fan speed) (max. 64 groups/indoor units)
- › Set back schedule
- › Enhanced scheduling function (8 schedules, 17 patterns)
- › Flexible grouping in zones
- › Yearly schedule
- › Fire emergency stop control
- › Interlocking control
- › Increased HRV monitoring and control function
- › Automatic cooling / heating change-over
- › Heating optimization
- › Temperature limit
- › Password security: 3 levels (general, administration & service)
- › Quick selection and full control
- › Simple navigation

Monitoring

- › Visualisation via Graphical User Interface (GUI)
- › Icon colour display change function
- › Indoor units operation mode
- › Indication filter replacement

Cost performance

- › Free cooling function
- › Labour saving
- › Easy installation
- › Compact design: limited installation space
- › Overall energy saving

Open interface

- › Communication to any third party controller (domotics, BMS, etc.) is possible via open interface (http option)

Connectable to

- › VRV
- › HRV
- › Sky Air
- › Split (via interface adapter)



DCM601A51

Mini BMS

with full integration
across all product pillars

- Price competitive mini BMS
- Cross-pillar integration of Daikin products
- Integration of third party equipment

System overview

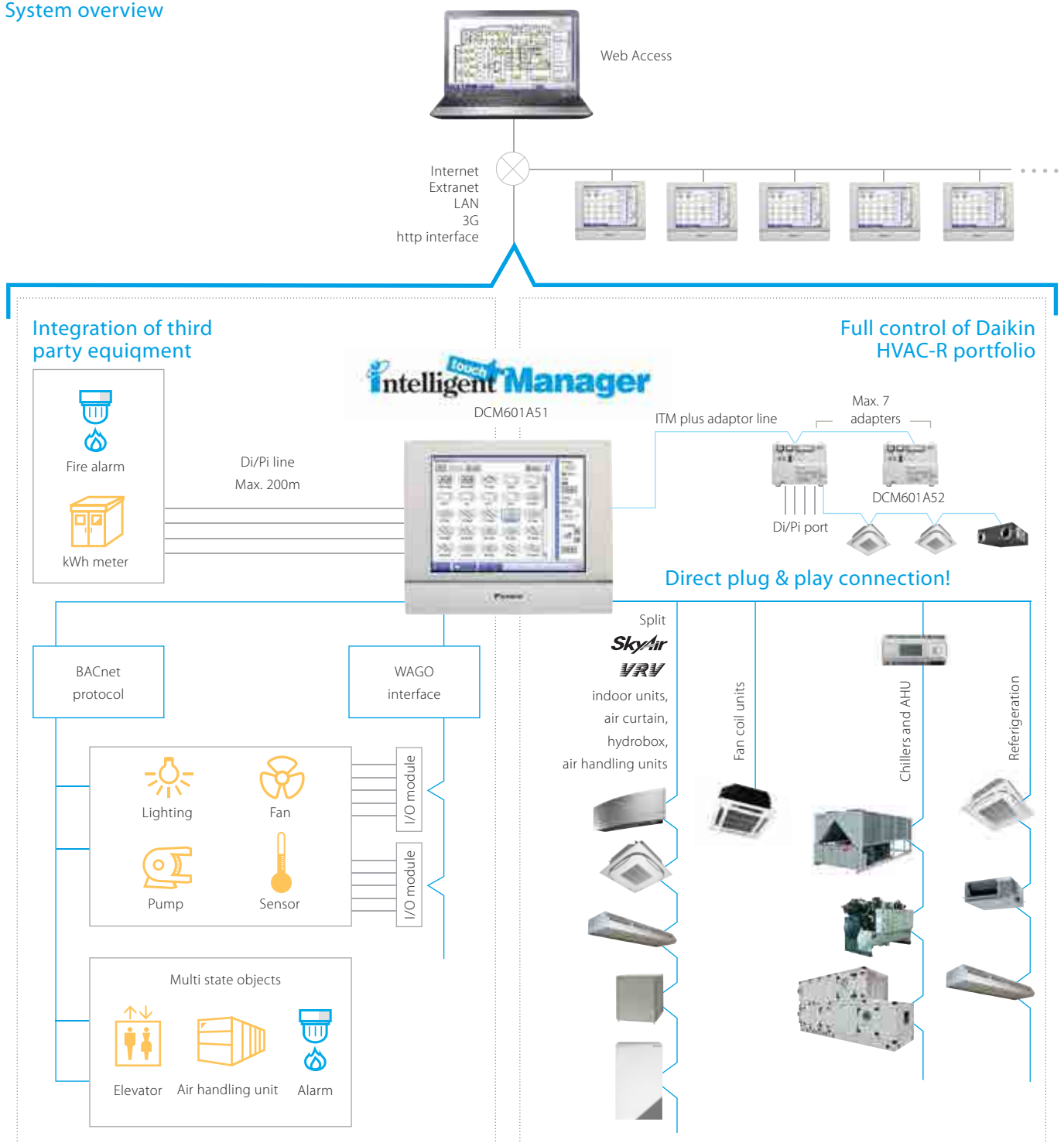



User friendliness

- › Intuitive user interface
- › Visual lay out view and direct access to indoor unit main functions
- › All functions direct accessible via touch screen or via web interface

Smart energy management

- › Monitoring if energy use is according to plan
- › Helps to detect origins of energy waste
- › Powerful schedules guarantee correct operation throughout the year
- › Save energy by interlocking A/C operation with other equipment such as heating

Flexibility

- NEW** › Cross-pillar integration (heating, air conditioning, applied systems, refrigeration, air handling units)
- NEW** › BACnet protocol for 3rd party products integration
- › I/O for integration of equipment such as lights, pumps... on WAGO modules
- › Modular concept for small to large applications
- › Control up to 512 indoor unit groups via one ITM and combine multiple ITM via the web interface

Easy servicing and commissioning

- › Remote refrigerant containment check preventing on site visit
- › Simplified troubleshooting
- › Save time on commissioning thanks to the pre-commissioning tool
- › Auto registration of indoor units

Functions overview

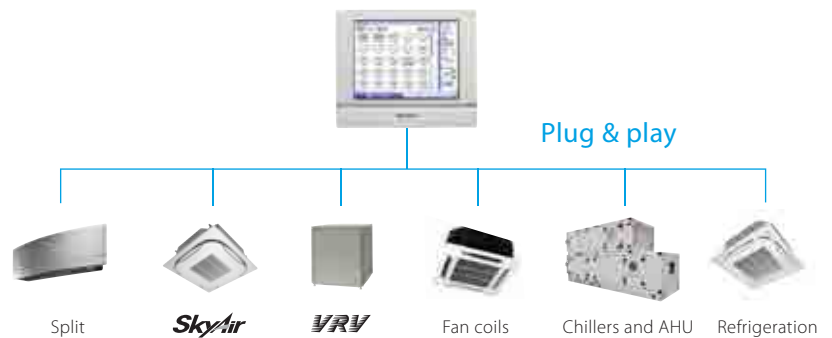

Languages

- › English
- › French
- › German
- › Italian
- › Spanish
- › Dutch
- › Portuguese

System layout

- › Up to 2,560 unit groups can be controlled (ITM plus Integrator + 7 iPU (incl. iTM adaptor)
- › Ethernet TCP/IP

Management

- › Web access
- › Power Proportional Distribution (option)
- › Operational history (malfunctions, operation hours, ...)
- › Smart energy management
 - monitor if energy use is according to plan
 - detect origins of energy waste
- › Setback function
- › Sliding temperature

Control

- › Individual control (2,560 groups)
- › Schedule setting (Weekly **NEW** schedule, yearly calendar, seasonal schedule)
- › Interlock control
- › Setpoint limitation
- › Temperature limit

WAGO Interface

- › Modular integration of 3rd party equipment
 - WAGO coupler (interface between WAGO and Modbus)
 - Di module
 - Do module
 - Ai module
 - Thermistor module

Connectable to

- DX Split, Sky Air, VRV
- Chillers (via POL638.70 controller)
- NEW** - Daikin AHU
- Fan coils
- Daikin Altherma Flex type
- LT and HT hydroboxes
- Air curtains
- WAGO I/O, AO and PI
- NEW** - BACnet protocol

Modbus Interface

RTD

Integration of RA, Sky Air, VRV,
in BMS or home automation
systems

RTD-RA

- › Modbus interface for monitoring and controlling residential indoor units

RTD-NET

- › Modbus interface for monitoring and controlling Sky Air, VRV, VAM and VKM

RTD-10

- › Advanced integration into BMS of Sky Air, VRV, VAM and VKM through either:
 - Modbus
 - Voltage (0-10V)
 - Resistance
- › Duty/standby function for server rooms

RTD-20

- › Advanced control of Sky Air, VRV, VAM/VKM and air curtains
- › Cloned or independent zone control
- › Increased comfort with integration of CO2 sensor for fresh air volume control
- › Save on running costs via
 - pre/post and trade mode
 - setpoint limitation
 - overall shut down
 - PIR sensor for adaptive deadband

RTD-HO

- › Modbus interface for monitoring and controlling Sky Air, VRV, VAM and VKM
- › Intelligent hotel room controller

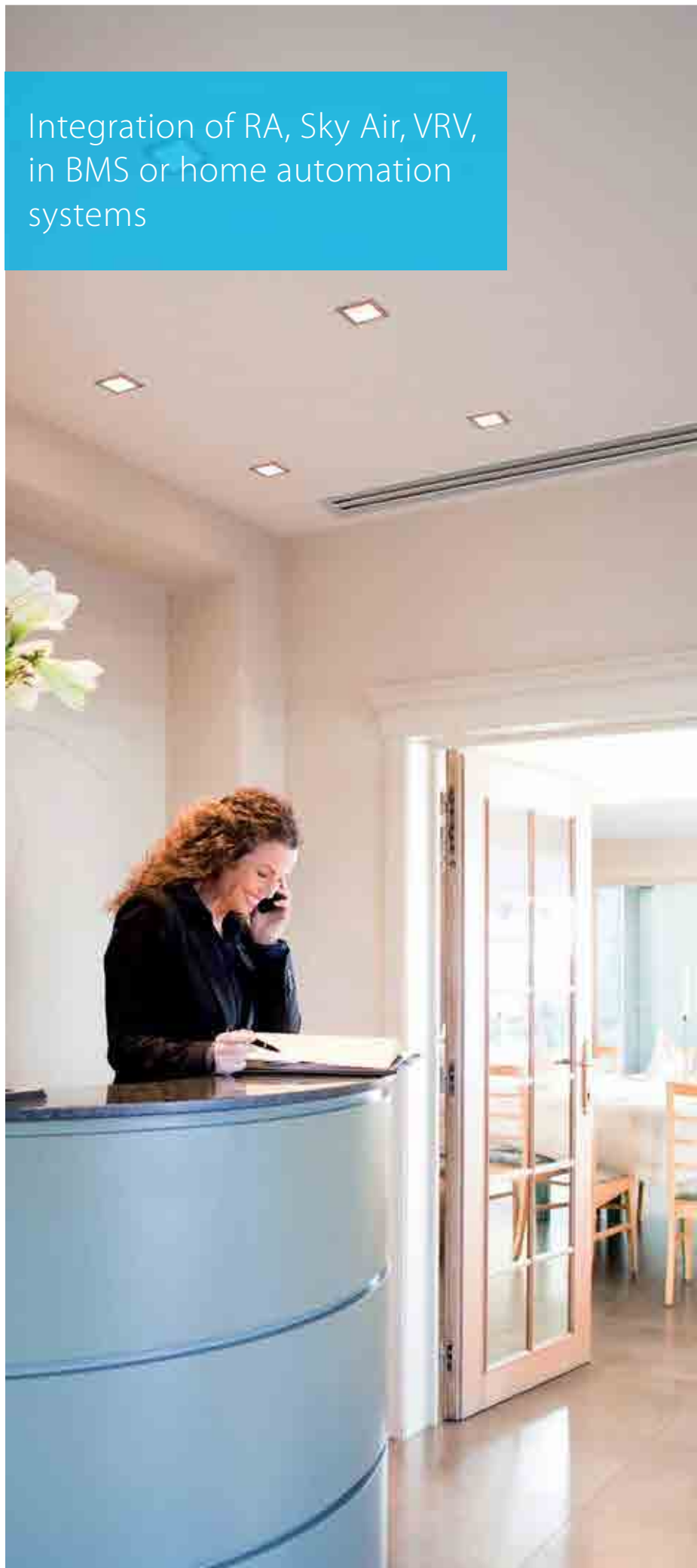

Overview functions



Main functions	RTD-RA	RTD-NET	RTD-10	RTD-20	RTD-HO
Dimensions H x W x D mm	80 x 80 x 37,5			100 x 100 x 22	
Key card + window contact					✓
Set back function	✓				✓
Prohibit or restrict remote control functions (setpoint limitation,...)	✓	✓	✓	✓**	✓
Modbus (RS485)	✓	✓	✓	✓	✓
Group control	✓(1)	✓	✓	✓	✓
0 - 10 V control			✓	✓	
Resistance control			✓	✓	
IT application	✓		✓	✓	
Heating interlock			✓	✓	
Output signal (on/defrost, error)			✓	✓****	✓
Retail application				✓	
Partitioned room control				✓	
Air curtain		✓***	✓***	✓	

(1): By combining RTD-RA devices

Control functions	RTD-RA	RTD-NET	RTD-10	RTD-20	RTD-HO
On/Off	M,C	M	M,V,R	M	M*
Set point	M	M	M,V,R	M	M*
Mode	M	M	M,V,R	M	M*
fan	M	M	M,V,R	M	M*
Louver	M	M	M,V,R	M	M*
HRV Damper control		M	M,V,R	M	
Prohibit/Restrict functions	M	M	M,V,R	M	M*
Forced thermo off	M				

Monitoring functions	RTD-RA	RTD-NET	RTD-10	RTD-20	RTD-HO
On/Off	M	M	M	M	M
Set point	M	M	M	M	M
Mode	M	M	M	M	M
fan	M	M	M	M	M
Louver	M	M	M	M	M
RC temperature		M	M	M	M
RC mode		M	M	M	M
nbr units		M	M	M	M
Fault	M	M	M	M	M
Fault code	M	M	M	M	M
Return air temperature (Average /Min/Max)	M	M	M	M	M
Filter alarm		M	M	M	M
Thermo on	M	M	M	M	M
Defrost		M	M	M	M
Coil In/Out temperature	M	M	M	M	M

M : Modbus / R: Resistance / V : Voltage / C: control

* : only when room is occupied / ** : setpoint limitation / (*) if available

*** : no fan speed control on the CYV air curtain / **** : run & fault

DIII-net Modbus interface

EKMBDXA

Integrated control system for seamless connection between Sky Air and VRV and BMS systems



- > Communication via Modbus RS485 protocol
- > Detailed monitoring and control of the VRV total solution
- > Easy and fast installation via DIII-net protocol
- > As the Daikin DIII-net protocol is being used, only one modbus interface is needed per Daikin unit

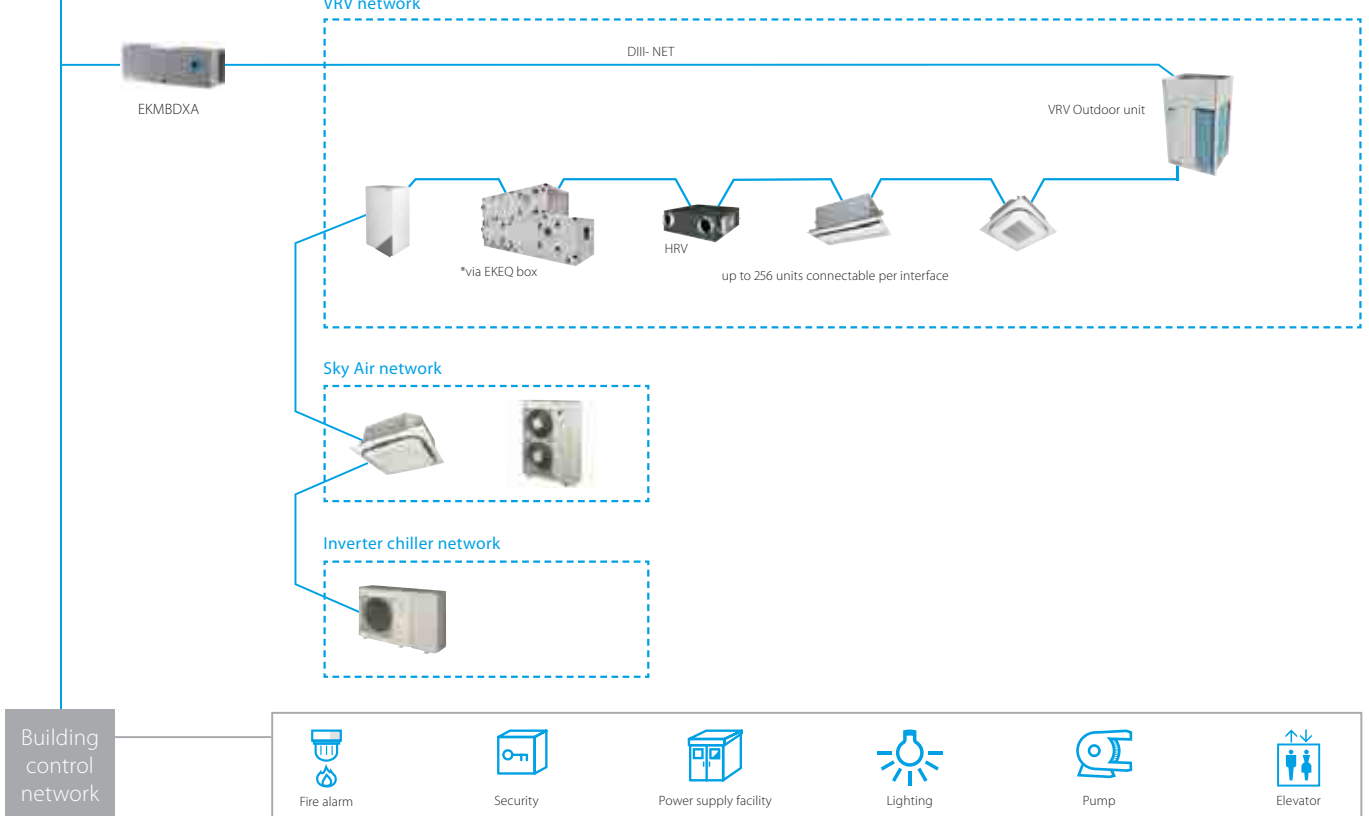

		EKMBDXA7V1		
Maximum number of connectable indoor units		64		
Maximum number of connectable outdoor units		10		
Communication	DIII-NET - Remark	DIII-NET (F1F2)		
	Protocol - Remark	2 wire; communication speed: 9600 bps or 19200 bps		
	Protocol - Type	RS485 (modbus)		
	Protocol - Max. Wiring length	m	500	
Dimensions	HeightxWidthxDepth	mm	124x379x87	
Weight		kg	2.1	
Ambient temperature - operation	Max.	°C	60	
	Min.	°C	0	
Installation			Indoor installation	
Power supply	Frequency	Hz	50	
	Voltage	V	220-240	

KNX interface

KLIC-DD
KLIC-DI

Integration of Split, Sky Air and VRV in HA/BMS systems

Connect split indoor units to KNX interface for Home Automation system



Connect Sky Air / VRV indoor units to KNX interface for BMS integration

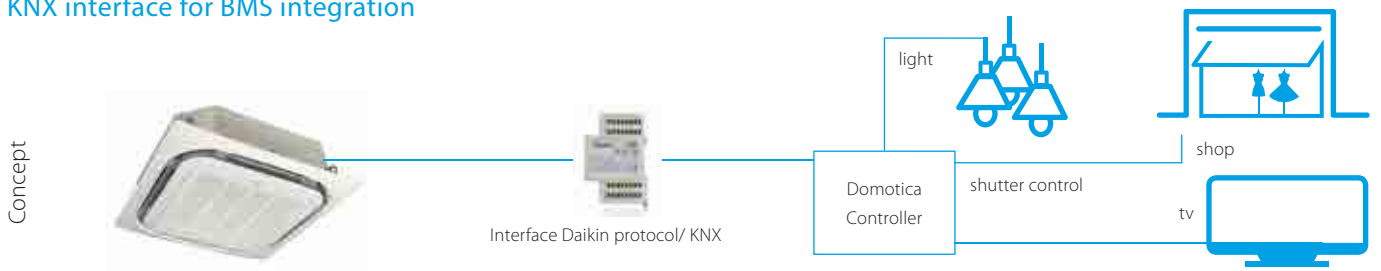



KNX interface line-up

The integration of Daikin indoor units through the KNX interface allows monitoring and control of several devices, such as lights and shutters, from one central controller. One particularly important feature is the ability to programme a 'scenario' - such as "Home leave" - in which the end-user selects

a range of commands to be executed simultaneously once the scenario is selected. For instance in "Home leave", the air conditioner is off, the lights are turned off, the shutters are closed and the alarm is on.

KNX interface for

	 KLIC-DD Size 45x45x15mm	 KLIC-DI Size 90x60x35mm	
	Split	Sky Air	VRV
Basic control			
On/Off	●	●	●
Mode	Auto, heat, dry, fan, cool	Auto, heat, dry, fan, cool	Auto, heat, dry, fan, cool
Temperature	●	●	●
Fan speed levels	3 or 5 + auto	2 or 3	2 or 3
Swing	Stop or movement	Stop or movement	Swing or fixed positions (5)
Advanced functionalities			
Error management	Communication errors, Daikin unit errors		
Scenes	●	●	●
Auto switch off	●	●	●
Temperature limitation	●	●	●
Initial configuration	●	●	●
Master and slave configuration		●	●

BACnet Interface

Integrated control system for seamless connection between VRV, applied systems, air handling units and BMS systems

- > Interface for BMS system
- > Communication via BACnet protocol (connection via Ethernet)
- > Unlimited sitesize
- > Easy and fast installation
- > PPD data is available on BMS system (only for VRV)

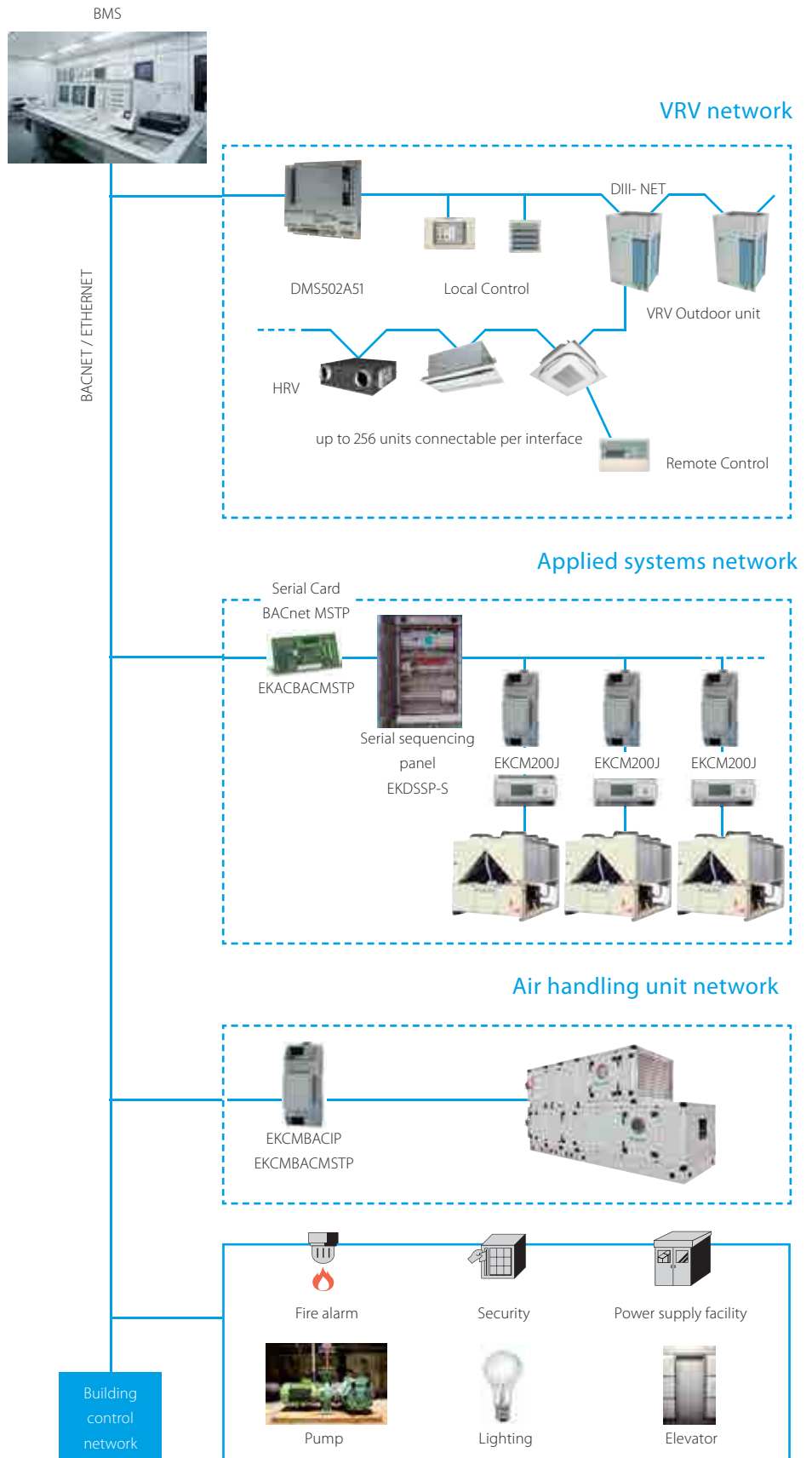

LonWorks Interface

Open network integration of VRV and applied systems monitoring and control functions into LonWorks networks

- > Interface for Lon connection to LonWorks networks
- > Communication via Lon protocol (twisted pair wire)
- > Unlimited sitesize
- > Quick and easy installation

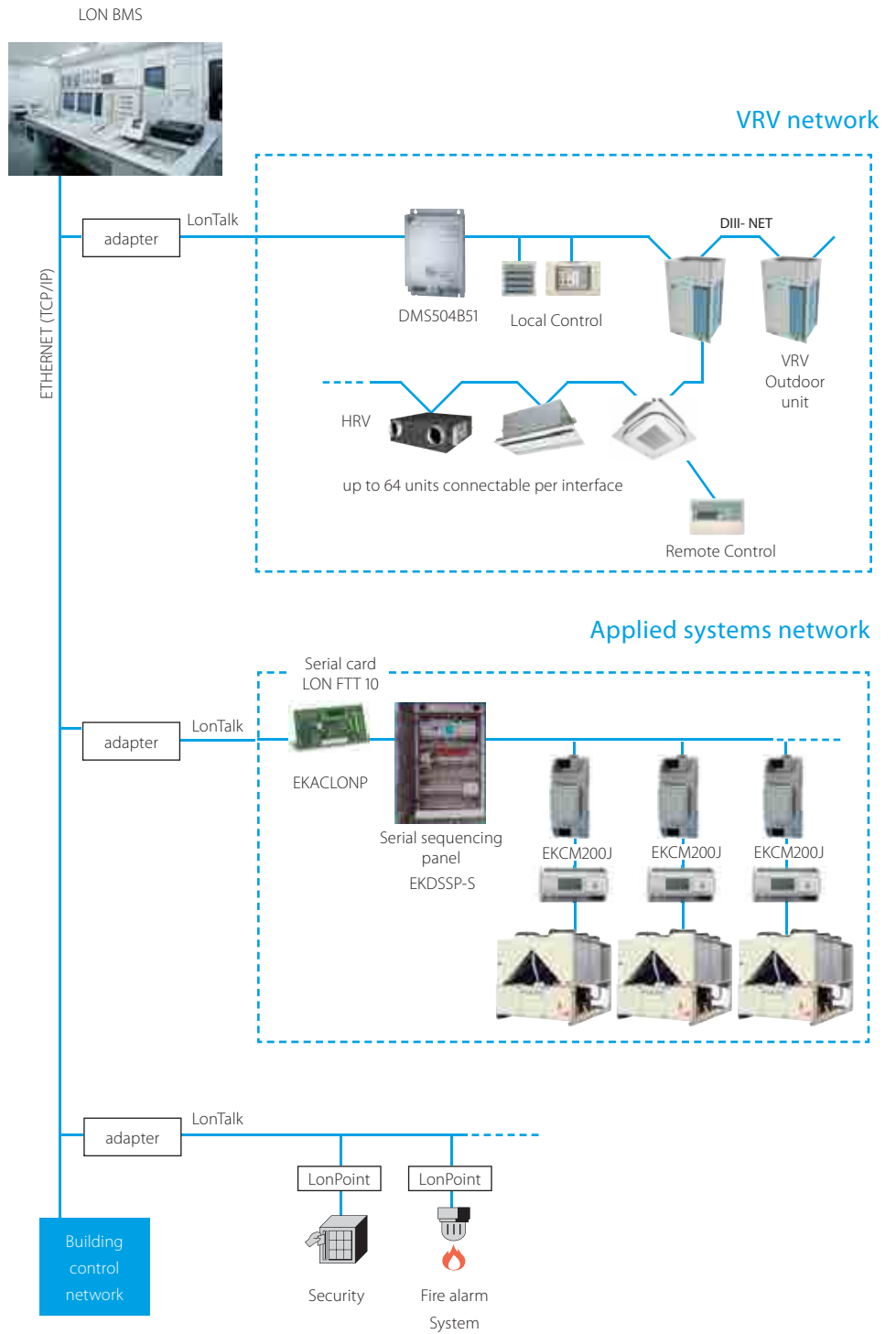

Daikin Configurator Software

EKPCCAB3

Simplified commissioning:
graphical interface to configure, commission
and upload system settings

Simplified commissioning

The Daikin configurator for Daikin Altherma and VRV is an advanced software solution that allows for easy system configuration and commissioning:

- › Less time is required on the roof configuring the outdoor unit
- › Multiple systems at different sites can be managed in exactly the same way, thus offering simplified commissioning for key accounts
- › Initial settings on the outdoor unit can be easily retrieved



Simplified
commissioning



Retrieve initial
system settings





What is I-Net?

A service based on our global remote monitoring technology, keeping your system trouble-free and working with top efficiency.

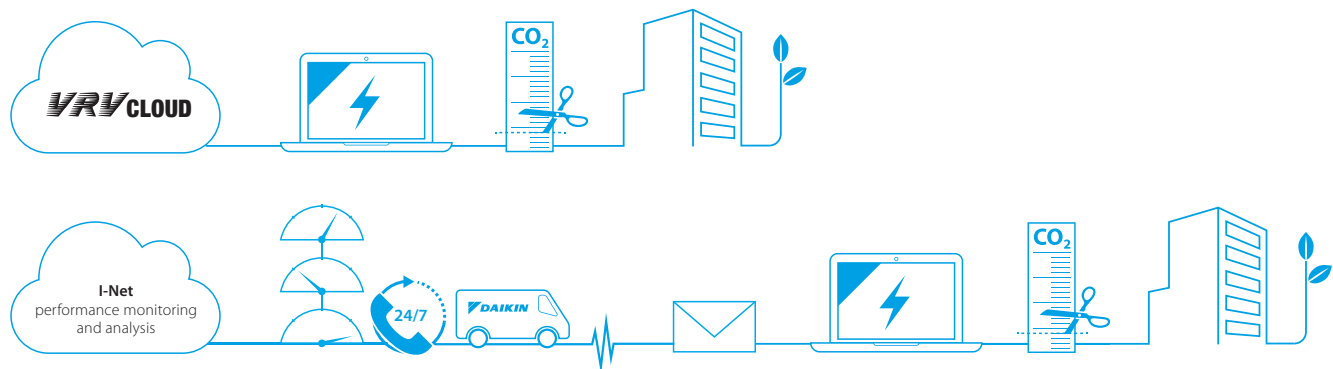

What does I-Net offer you

Safeguarding the lifelong optimum operation of your air conditioning system means getting geared up to operate the system in a energy efficient way and reduce unexpected breakdowns and costs to the absolute minimum. This is where I-Net helps to improve the effectiveness of your building management.

I-Net is about 'being connected' with Daikin, the Internet-based link between you, your air conditioning system and Daikin's Remote Monitoring Centre. This allows you to monitor your energy consumption and Daikin's expert service engineers to monitor your entire system's status non-stop, all year round. Through predicting malfunctions and offering technical advice from data analysis, you can maximise equipment uptime, as well as controlling energy costs with no sacrifice in comfort levels. By doing this, i-Net will prevent problems, prolong your system's service life while reducing the energy bill.

I-Net Services

i-Net consists of 2 main services: the VRV Cloud and I-Net performance monitoring and analysis.

VRV Cloud

The VRV Cloud puts you in the driving seat of your energy management. The easy-to-use energy data trending and analytic tools puts you in control and shows you CO2 footprint reduction opportunities and energy savings of up to 15%.

Saving starts by measuring. Enhance your company's sustainability !

I-Net performance monitoring and analysis

Focus on your core business and hand the HVAC over to Daikin. Daikin I-Net connects your system continuously with Daikin. It notifies alarms and early warnings of system deviations to maximise system uptime and the comfort of the people in the building. Service providers have webbased access to operation data so that they are fully prepared when they arrive on-site. Specialists run trend analyses. All of which boosts your system's reliability by ensuring that it is running at optimum efficiency.

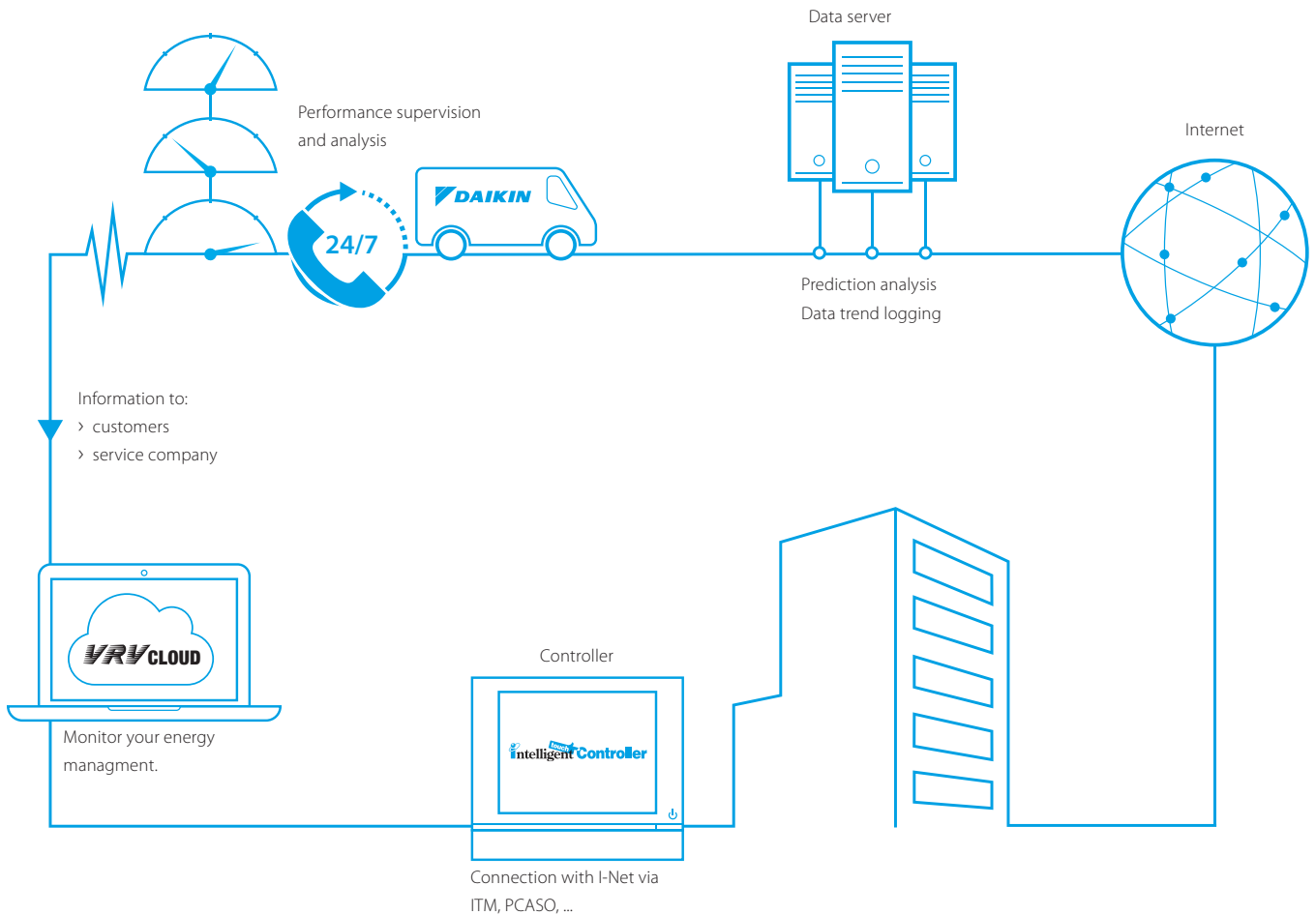

i-Net

Daikin VRV Cloud

Helps you manage your energy through Daikin technology.

- > Intelligent energy visualization tool that helps you with your energy management
- > 24/7 online monitoring by the customer from any location.
- > User friendly visualization of VRV energy management (kWh)
- > Analysis support of waste operation
- > Multiple site monitoring

- > Performance Supervision by Daikin experts enhances a maintenance plan.
- > This service aims to enhance the service level, to respond fast and accurate, to save on unexpected repair costs and assure the peace of mind. Repetitive interventions and disturbance of building tenants and maintenance teams are kept to a minimum.

Long lifetime systems

- > I-Net will maximise the installation's lifetime, by assuring the equipment runs in optimal conditions and avoid unnecessary stress on components.

Performance monitoring

Daikin's unique I-Net Service aims to prevent the equipment coming to an unexpected stop or needing emergency repair.

Fast response, better prepared

- > If an alarm does occur, the service provider is immediately alerted and receives all crucial information.
- > Early fault indication (predictions) : operation data are 24/7 checked by I-Net prediction algorithms to act as early as possible, averting unscheduled breakdowns.

Analysis

Be connected with Daikin's experts, this gives you a clear overview of operability and use of the air conditioning system.

- > Daikin continuously monitors energy, operation and comfort data. Thanks to periodic analysis of the data, Daikin can suggest ways of improving performance.
- > if there is a problem, Daikin specialists will analyse the operation data history to provide remote support.

Wireless room temperature sensor

K.RSS



Flexible and easy installation

- › Accurate temperature measurement thanks to flexible placement of the sensor
- › No need for wiring
- › No need to drill holes
- › Ideal for refurbishment

Connection diagram Daikin indoor unit PCB (FXSQ-P example)



Specifications

				Wireless room temperature sensor kit (K.RSS)	
				Wireless room temperature receiver	Wireless room temperature sensor
Dimensions	mm	50 x 50		ø 75	
Weight	g	40		60	
Power supply		16VDC, max. 20 mA		N/A	
Battery life		N/A		+/- 3 years	
Battery type		N/A		3 Volt Lithium battery	
Maximum range	m	10			
Operation range	°C	0~50			
Communication	Type	RF			
	Frequency	MHz	868.3		

- › Room temperature is sent to the indoor unit every 90 seconds or if the temperature difference is 0.2°C or larger.

Wired room temperature sensor

KRCS01-1B
KRCS01-4B



- › Accurate temperature measurement, thanks to flexible placement of the sensor





Specifications

Dimensions (HxW)	mm	60 x 50
Weight	g	300
Length of branch wiring	m	12

ADAPTER PCBs

Simple solutions for unique requirements

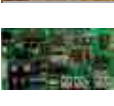
Daikin's adapter PCBs provide simple solutions for unique requirements. They are a low cost option to satisfy simple control requirements and can be used on single or multiple units.

	(E)KRP1B* adapter for wiring	<ul style="list-style-type: none"> Facilitates integration of auxiliary heating apparatus, humidifiers, fans, damper Powered by and installed at the indoor unit
	KRP2A*/KRP4A* Wiring adapter for electrical appendices	<ul style="list-style-type: none"> Remotely start and stop up to 16 indoor units (1 group) (KRP2A* via P1 P2) Remotely start and stop up to 128 indoor units (64 groups) (KRP4A* via F1 F2) Alarm indication/ fire shut down Remote temperature setpoint adjustment
	DTA104A* Outdoor Unit External Control Adapter	<ul style="list-style-type: none"> Individual or simultaneous control of VRV system operating mode Demand control of individual or multiple systems Low noise option for individual or multiple systems
	KRP928* Interface adapter for DIII-net	<ul style="list-style-type: none"> Allows integration of split units to Daikin central controls
	KRP413* Wiring adapter normal open contact / normal open pulse contact	<ul style="list-style-type: none"> Switch off auto restart after power failure Indication of operation mode / error Remotely start /stop Remotely change operation mode Remotely change fan speed
	KRP980* Adapter for split units without an S21 port	<ul style="list-style-type: none"> Connect a wired remote control Connect to Daikin central controls Allow external contact

Concept and benefits

- › Low cost option to satisfy simple control requirements
- › Deployed on single or multiple units



AUTO-CLEANING PANEL



FILTERS

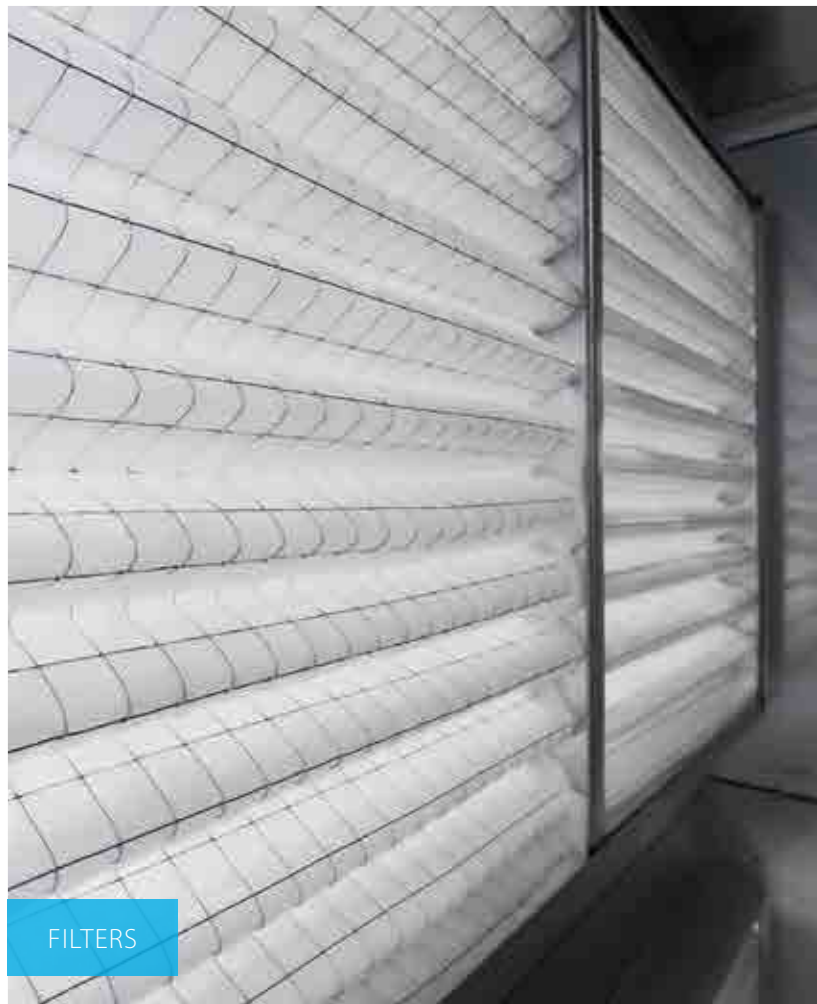

INTELLIGENT SENSORS

Options & accessories

VRV outdoor	240
VRV indoor	242
Stylish indoor	246
Ventilation & Hot Water	248
Control Systems	251

	VRV IV with continuous heating						VRV IV without	
	RYYQ8-12T	RYYQ14-20T	RYMQ8-12T	RYMQ14-20T	2-module systems	3-module systems	RXYQ8-12T(9)	RXYQ14-20T
Multi-module connection kit (obligatory) - Connects multiple modules into a single refrigerant system	-	-	-	-	BHFQ22P1007	BHFQ22P1517	-	-
Extended level difference kit - Allows outdoor unit to be more than 50m above indoor units	-	-	-	-	-	-	-	-
Central drain pan kit - Installs onto the underside of the outdoor unit and collects drain water from all bottom plate outlets into a single outlet. In cold areas should be heated by a field-supplied heater to prevent drain water from freezing in the drain pan.	-	-	-	-	-	-	-	-
Heater tape kit - Optional electrical heater to guarantee trouble-free operation in extremely cold and humid climates (one per outdoor unit needed)	EKBPH012T + EKBPHPCBT	EKBPH020T + EKBPHPCBT	EKBPH012T + EKBPHPCBT	EKBPH020T + EKBPHPCBT	-	-	EKBPH012T + EKBPHPCBT	EKBPH020T + EKBPHPCBT
External control adapter for outdoor unit - Allows to activate Low Noise Operation and three levels of Demand Limiting via external dry contacts. Connects to the F1/F2 communication line and requires power supply from an indoor unit*, BSVQ box, or VRV-WIII outdoor unit.	For installation into an indoor unit: exact adapter type depends on type of indoor unit. See Options & Accessories of indoor units							
BHGP26A1 - Digital pressure gauge kit – displays current condensing and evaporating pressures in the system as standard, or expansion valve positions and temperature sensor data in a special service mode. Connect to the outdoor unit PCB, for installation in the outdoor unit.	●	●	●	●	1 kit per system	1 kit per system	●	●
KRC19-26A - Mechanical cool/heat selector – allows to switch an entire Heat Pump system, or one BS-box of a Heat Recovery system between cooling, heating and fan only. Connects to the A-B-C terminals of the outdoor unit / BS-box.	●	●	●	●	●	●	●	●
BRP2A81 - Cool/heat selector PCB (required for VRV IV)	●	●	●	●	●	●	●	●
KKSA26A560* - Cool/heat selector PCB mounting plate (only required when cool/heat selector PCB and Heater tape kit are combined)	●	●	●	●	●	●	●	●
KJB111A - Installation box for remote cool/heat selector KRC19-26A	●	●	●	●	●	●	●	●
EKPCAB3 - VRV configurator	●	●	●	●	●	●	●	●
BPMKS967A2/A3 - Branch provider (for connection of 2/3 RA indoor units)	●	●	-	-	-	-	●	●
KKPJ5F180 - Central drain plug	-	-	-	-	-	-	-	-
DTA104A61/62* - Demand PCB allowing external input to limit power consumption	●	●	●	●	●	●	●	●
KKSB2B61* - Demand PCB mounted plate. Needed to mount Demand PCB for some outdoor units.	-	●	-	●	-	-	-	-
DTA109A51 - DIII-net expander adapter	●	●	●	●	●	●	●	●

	VRV IV-Q Heat Pump Replacement VRV				
	RQYQ 140	RXYQ8-12T	RXYQ14-20T	2-module systems	3-module systems
Multi-module connection kit (obligatory) - Connects multiple modules into a single refrigerant system	-	-	-	BHFQ22P1007	BHFQ22P1517
Central drain pan kit - Installs onto the underside of the outdoor unit and collects drain water from all bottom plate outlets into a single outlet. In cold areas should be heated by a field-supplied heater to prevent drain water from freezing in the drain pan.	KWC26B160	-	-	-	-
Heater tape kit - Optional electrical heater to guarantee trouble-free operation in extremely cold and humid climates (one per outdoor unit needed)	-	EKBPH012T + EKBPHPCBT	EKBPH020T + EKBPHPCBT	-	-
External control adapter for outdoor unit - Allows to activate Low Noise Operation and three levels of Demand Limiting via external dry contacts. Connects to the F1/F2 communication line and requires power supply from an indoor unit*, BSVQ box, or VRV-WIII outdoor unit.	DTA104A53/61/62 For installation into an indoor unit: exact adapter type depends on type of indoor unit. See Options & Accessories of indoor units				
BHGP26A1 - Digital pressure gauge kit – displays current condensing and evaporating pressures in the system as standard, or expansion valve positions and temperature sensor data in a special service mode. Connect to the outdoor unit PCB, for installation in the outdoor unit.	●	●	●	1 kit per system	1 kit per system
KRC19-26A - Mechanical cool/heat selector – allows to switch an entire Heat Pump system, or one BS-box of a Heat Recovery system between cooling, heating and fan only. Connects to the A-B-C terminals of the outdoor unit / BS-box.	●	●	●	1 kit per system	1 kit per system
BRP2A81 - Cool/heat selector PCB (required for VRV IV)	-	●	●	●	●
KKSA26A560* - Cool/heat selector PCB mounting plate (only required when cool/heat selector PCB and Heater tape kit are combined)	-	-	●	●	●
KJB111A - Installation box for remote cool/heat selector KRC19-26A	●	●	●	1 kit per system	1 kit per system
EKPCAB3 - VRV configurator	-	●	●	●	●
DTA104A61/62* - Demand PCB allowing external input to limit power consumption	-	●	●	●	●
KKSB2B61* - Demand PCB mounted plate. Needed to mount Demand PCB for some outdoor units.	-	-	●	-	-
DTA109A51 - DIII-net expander adapter	●	●	●	●	●

	Refnet Joints				Refnet Headers		
	Capacity index	Capacity index	Capacity index	Capacity index	Capacity index	Capacity index	
	< 201	201~290	291~640	> 640	< 291	291~640	
Heat Recovery systems (3-pipe)	Metric-size connections	KHRQM23M20T	KHRQM23M29T	KHRQM23M64T	KHRQM23M75T	KHRQM23M29H	KHRQM23M64H
	Imperial-size connections	KHRQ23M20T	KHRQ23M29T9	KHRQ23M64T	KHRQ23M75T	KHRQ23M29H	KHRQ23M64H
	Sound reduction kit (sound insulation)	-	-	-	-	-	-
	Mechanical cool/heat selector – allows to switch an entire Heat Pump system, or one BS-box of a Heat Recovery system between cooling, heating and fan only. Connects to the A-B-C terminals of the outdoor unit / BS-box.	-	-	-	-	-	-
	Installation box for remote cool/heat selector KRC19-26	-	-	-	-	-	-
	Closed pipe kit	-	-	-	-	-	-
	Joint kit	-	-	-	-	-	-
Heat Pump systems (2-pipe)	Metric-size connections	KHRQM22M20T	KHRQM22M29T	KHRQM22M64T	KHRQM22M75T	KHRQM22M29H	KHRQM22M64H
	Imperial-size connections	KHRQ22M20T	KHRQ22M29T9	KHRQ22M64T	KHRQ22M75T	KHRQ22M29H	KHRQ22M64H

continuous heating		VRV III-S Mini VRV	VRV III-C Cold Region VRV			VRV Classic			VRV IV Heat Recovery				
2-module systems	3-module systems	RXYSQ	RTSYQ 10	RTSYQ 14~16	RTSYQ 20	RXYCQ8A	RXYCQ10-14A	RXYCQ16-20A	REYQ 8~12	REYQ 14~20	REMQ5	2-module systems	3-module systems
BHFQ22P1007	BHFQ22P1517	-	-	-	BHFQ22P1007	-	-	-	-	-	-	BHFQ23P907	BHFQ23P1357
-	-	-	-	-	-	-	-	-	Special order unit				
-	-	-	KWC26B280	KWC26B450	2x KWC26B280	KWC26B160	KWC26B280	KWC26B450	-	-	-	-	-
-	-	-	BEH22A10Y1L	BEH22A18Y1L	2x BEH22A10Y1L	-	-	-	EKBPH012T + EKBHPCBT	EKBPH020T + EKBHPCBT	EKBPH012T + EKBHPCBT	-	-
For installation into an indoor unit: exact adapter type depends on type of indoor unit. See Options & Accessories of indoor units													
1 kit per system	1 kit per system	-	●	●	●	●	●	●	●	●	●	1 kit per system	1 kit per system
●	●	●	-	-	-	●	●	●	-	-	-	-	-
●	●	-	-	-	-	-	-	-	-	-	-	-	-
●	●	-	-	-	-	-	-	-	-	-	-	-	-
●	●	●	-	-	-	●	●	●	-	-	-	-	-
●	●	-	-	-	-	-	-	-	●	●	●	●	●
-	-	●	-	-	-	-	-	-	-	-	-	-	-
-	-	●	-	-	-	-	-	-	-	-	-	-	-
●	●	-	-	-	-	-	-	-	-	-	-	-	-
-	-	-	-	-	-	-	-	-	-	-	-	-	-
●	●	●	●	●	●	●	●	●	●	●	●	●	●
VRV III-Q Heat Recovery Replacement VRV				VRV-W IV Water-cooled VRV									
RQEYQ 140~212	2-module systems	3-module systems	4-module systems	RWEYQ8-10T	Heat Pump application		Heat Recovery application						
-	BHFP26P36C	BHFP26P63C	BHFP26P84C	-	2-module systems	3-module systems	2-module systems	3-module systems					
-	-	-	-	-	BHFQ22P1007	BHFQ22P1517	BHFQ23P907	BHFQ23P1357					
KWC26B160	1 kit per module	1 kit per module	1 kit per module	-	-	-	-	-					
-	-	-	-	-	-	-	-	-					
DTA104A53/61/62				DTA104A62									
For installation into an indoor unit: exact adapter type depends on type of indoor unit. See Options & Accessories of indoor units				Installation in the RWEYQ outdoor unit possible. For installation in indoor units, use appropriate type (DTA104A53/61/62) for particular indoor unit. See Options & Accessories of indoor units									
●	1 kit per system	1 kit per system	1 kit per system	-	-	-	-	-					
-	-	-	-	●	1 kit per system	1 kit per system	-	-					
-	-	-	-	●	1 kit per system	1 kit per system	-	-					
-	-	-	-	●	1 kit per system	1 kit per system	-	-					
-	-	-	-	●	●	●	●	●					
-	-	-	-	-	-	-	-	-					
-	-	-	-	-	-	-	-	-					
●	●	●	●	●	●	●	●	●					
Heat Recovery Branch Selector Boxes (BS-Boxes)													
Capacity index > 640	1-port	1-port	4-port	4-port	6-port	6-port	8-port	10-port	12-port	16-port			
KHRQ23M75H	-	-	-	-	-	-	-	-	-	-			
KHRQ23M75H	BS1Q-A	BSVQ-P8B	BS4Q14A	BSV4Q100PV	BS6Q14A	BSV6Q100PV	BS8Q14A	BS10Q14A	BS12Q14A	BS16Q14A			
-	EKBSVQLNP	EKBSVQLNP	-	-	-	-	-	-	-	-			
-	-	KRC19-26	-	KRC19-26 1 kit per port necessary	-	KRC19-26 1 kit per port necessary	-	-	-	-			
-	-	KJB111A	-	KJB111A	-	KJB111A	-	-	-	-			
-	-	-	KHFP26A100C	-	KHFP26A100C	-	KHFP26A100C	KHFP26A100C	KHFP26A100C	KHFP26A100C			
-	-	-	KHRP26A1250C	-	KHRP26A1250C	-	KHRP26A1250C	KHRP26A1250C	KHRP26A1250C	KHRP26A1250C			
-	-	-	KDDN26A4	-	KDDN26A8	-	KDDN26A8	KDDN26A12	KDDN26A12	KDDN26A16			
KHRQ22M75H	-	-	-	-	-	-	-	-	-	-			
KHRQ22M75H	-	-	-	-	-	-	-	-	-	-			

*Note: blue cells contain preliminary data

		Ceiling mounted cassette units				
		Round flow (800x800)	4-way (600x600)	2-way blow		
		FXFQ 20~125A	FXZQ 15~50A	FXCQ 20~40A	FXCQ 50~63A	FXCQ 80 ~125A
Adapters and control	BRC1E52A/B Premium wired remote control with full-text interface and back-light	●	●	●	●	●
	BRC1D52 Standard wired remote control with weekly timer	●*4	●*4	●*4	●*4	●*4
	Infrared remote control including receiver	BRC7FA532F	BRC7F530W *9*10 (white panel) BRC7F530S *9*10 (grey panel) BRC7EB530 *9*10 (standard panel)	BRC7C52	BRC7C52	BRC7C52
	BRC2E52A Simplified wired remote control for heat recovery system	-	-	-	-	-
	BRC3E52A Simplified wired remote control for heat pump system	-	-	-	-	-
	DCS302C51 Central remote control	●	●	●	●	●
	DCS301B51 Unified ON/OFF control	●	●	●	●	●
	DST301B51 Schedule timer	●	●	●	●	●
	DCM601A51 Intelligent Touch Manager	●	●	●	●	●
	External wired temperature sensor	KRCS01-4	KRCS01-4	KRCS01-4	KRCS01-4	KRCS01-4
	External wireless temperature sensor	K.RSS	K.RSS	K.RSS	K.RSS	K.RSS
	Adaptor for wiring (interlock for fresh air intake fan)	-	-	-	-	-
	Wiring adapter for external monitoring/control via dry contacts and setpoint control via 0-140Ω	KRP4A53 *2*7	KRP4A53 *2	KRP4A51	KRP4A51	KRP4A51
	Wiring adapter for external central monitoring/control (controls 1 entire system)	-	KRP2A52	KRP2A51	KRP2A51	KRP2A51
	Wiring adapter with 4 output signals (Compressor / Error, Fan, Aux. heater, Humidifier output)	EKRP1C11 *2*7	EKRP1B2	EKRP1B2	EKRP1B2	EKRP1B2
	Wiring adapter with 2 output signals (Compressor / Error, Fan output)	KRP1B57 *2*7	KRP1B57	-	-	-
	Adapter for multi-tenant applications (24VAC PCB power supply interface)	DTA114A61	DTA114A61	-	-	-
	External control adapter for outdoor unit	-	-	DTA104A61	DTA104A61	DTA104A61
	Installation box / Mounting plate for adapter PCBs (For units where there is no space in the switchbox)	KRP1H98 *7	KRP1A101	KRP1C96	KRP1C96	KRP1C96
	Connector for forced-off contact	standard	-	standard	standard	standard
	Connection to centralized control	standard	-	-	-	-
	Electrical box with earth terminal (2 blocks)	KJB212A	-	KJB212A	KJB212A	KJB212A
	Electrical box with earth terminal (3 blocks)	KJB311A	-	KJB311A	KJB311A	KJB311A
Electrical box with earth terminal	-	-	-	-	-	
Digital input adaptor	-	-	-	-	-	

Others	Decoration panel (obligatory for cassette units, optional for others, rear panel for FXLQ)	BYCQ140D7GW1 (self clean) *5/*6 BYCQ140D7WIW (white) *3 BYCQ140D7W1 (standard)	BYFQ60CW (white panel) BYFQ60CS (grey panel) BYFQ60B3 (standard panel)	BYBCQ40H	BYBCQ63H	BYBCQ125H
	Kit for mounting of decoration panel direct onto unit	-	-	-	-	-
	Panel spacer for reducing required installation height	-	KDBQ44B60 (standard panel)	-	-	-
	Sealing kit for 3-directional or 2-directional air discharge	KDBHQ55B140 *7	BDBHQ44C60 (white & grey panel)	-	-	-
	Fresh air intake kit	KDDQ55B140-1 + KDDQ55B140-2 *7*8	KDDQ44XA60	-	-	-
	Air discharge adapter for round duct	-	-	-	-	-
	Filter chamber for bottom suction	-	-	KDDFP53B50	KDDFP53B80	KDDFP53B160
	Replacement long life filter	KAFP551K160	KAFQ441BA60	KAFP531B50	KAFP531B80	KAFP531B160
	Drain pump kit	standard	standard	standard	standard	standard
	Sensor kit	BRYQ140A	BRYQ60AW (white panel) BRYQ60AS (grey panel)	-	-	-
	Noise filter (for electromagnetic use only)	-	-	KEK26-1A	KEK26-1A	KEK26-1A

*2 Installation box is necessary for these adapters

*3 The BYCQ140D7WIW has white insulation

Be informed that formation of dirt on white insulation is visibly stronger and that it is consequently not advised to install the BYCQ140D7WIW decoration panel in environments exposed to concentrations of dirt*

*4 Not recommended because of the limitation of the functions

*5 To be able to control the BYCQ140D7GW1 the controller BRC1E is needed

*6 The BYCQ140D7GW1 is not compatible with Mini VRV, Multi and Split Non-Inverter Outdoor units

*7 Option not available in combination with BYCQ140D7GW1

*8 Both parts of the fresh air intake are needed for each unit

*9 Sensing function not available

*10 Independently controllable flaps function not available

Corner (1-way blow)		Concealed ceiling units (duct units)						
		Small	Slim	Standard				
FXKQ 25~40	FXKQ 63	FXDQ 20~25 M9	FXDQ 15~63A	FXSQ 15~32	FXSQ 40~50	FXSQ 63~80	FXSQ 100~125	FXSQ 140
●	●	●	●	●	●	●	●	●
●*4	●*4	●*4	●*4	●*4	●*4	●*4	●*4	●*4
BRC4C61	BRC4C61	BRC4C62	BRC4C65	BRC4C65	BRC4C65	BRC4C65	BRC4C65	BRC4C65
-	-	●	●	●	●	●	●	●
-	-	●	●	●	●	●	●	●
●	●	●	●	●	●	●	●	●
●	●	●	●	●	●	●	●	●
●	●	●	●	●	●	●	●	●
●	●	●	●	●	●	●	●	●
KRCS01-1	KRCS01-1	KRCS01-1	KRCS01-4B	KRCS01-4B	KRCS01-4B	KRCS01-4B	KRCS01-4B	KRCS01-4B
K.RSS	K.RSS	K.RSS	K.RSS	K.RSS	K.RSS	K.RSS	K.RSS	K.RSS
-	-	-	-	-	-	-	-	-
KRP4A51	KRP4A51	KRP4A51	KRP4A54	KRP4A52 *2	KRP4A52 *2	KRP4A52 *2	KRP4A52 *2	KRP4A52 *2
KRP2A51	KRP2A51	KRP2A51	KRP2A53	KRP2A51 *2	KRP2A51 *2	KRP2A51 *2	KRP2A51 *2	KRP2A51 *2
KRP1B61	KRP1B61	EKRP1B2	KRP1B56	EKRP1B2 *2	EKRP1B2 *2	EKRP1B2 *2	EKRP1B2 *2	EKRP1B2 *2
-	-	-	-	-	-	-	-	-
-	-	EKMTAC	DTA114A61	DTA114A61	DTA114A61	DTA114A61	DTA114A61	DTA114A61
DTA104A61	DTA104A61	DTA104A61	DTA104A53	DTA104A61	DTA104A61	DTA104A61	DTA104A61	DTA104A61
-	-	-	KRP1B101	KRP1BA101 / KRP1B100	KRP1BA101 / KRP1B100	KRP1BA101 / KRP1B100	KRP1BA101 / KRP1B100	KRP1BA101 / KRP1B100
Standard	Standard	Standard	-	Standard	Standard	Standard	Standard	Standard
Standard	Standard	Standard	-	Standard	Standard	Standard	Standard	Standard
-	-	-	KJB212A	KJB212A	KJB212A	KJB212A	KJB212A	KJB212A
-	-	-	KJB311A	KJB311A	KJB311A	KJB311A	KJB311A	KJB311A
-	-	-	-	KJB411A	KJB411A	KJB411A	KJB411A	KJB411A
-	-	-	-	BRP7A51	BRP7A51	BRP7A51	BRP7A51	BRP7A51

BYK45F	BYK71F	-	-	-	-	-	-	-
-	-	-	-	-	-	-	-	-
-	-	-	-	-	-	-	-	-
-	-	-	-	-	-	-	-	-
-	-	-	-	-	-	-	-	-
-	-	-	-	KDAP25A36A	KDAP25A56A	KDAP25A71A	KDAP25A140A	-
-	-	-	-	-	-	-	-	-
-	-	-	-	-	-	-	-	-
Standard	Standard	KDAJ25K56	standard	Standard	Standard	Standard	Standard	Standard
-	-	-	-	-	-	-	-	-
-	-	-	KEK26-1A	-	-	-	-	-

		Concealed ceiling units (duct units)				
				Large		
		FXMQ 50~80	FXMQ 100~125	FXMQ 200~250	FXTQ50~63	FXTQ80~100
Adapters and control	BRC1E52A/B Premium wired remote control with full-text interface and back-light	•	•	•	•	•
	BRC1D52 Standard wired remote control with weekly timer	•*4	•*4	•*4	•*4	•*4
	Infrared remote control including receiver	BRC4C65	BRC4C65	BRC4C65	BRC4C65	BRC4C65
	BRC2E52A Simplified wired remote control for heat recovery system	•	•	•	•	•
	BRC3E52A Simplified wired remote control for heat pump system	•	•	•	•	•
	DCS302C51 Central remote control	•	•	•	•	•
	DCS301B51 Unified ON/OFF control	•	•	•	•	•
	DCS601C51 Schedule timer	•	•	•	•	•
	DCM601A51 Intelligent Touch Controller	•	•	•	•	•
	External wired temperature sensor	KRCS01-4	KRCS01-4	KRCS01-1	KRCS01-4B	KRCS01-1
	External wireless temperature sensor	K.RSS	K.RSS	K.RSS	K.RSS	K.RSS
	Wiring adapter for external monitoring/control via dry contacts and setpoint control via 0-140Ω	KRP4A51	KRP4A51	KRP4A51	KRP4A52 *2	KRP4A51
	Wiring adapter for external central monitoring/control (controls 1 entire system)	KRP2A51	KRP2A51	KRP2A51	KRP2A51 *2	KRP2A51
	Wiring adapter with 4 output signals (Compressor / Error, Fan, Aux. heater, Humidifier output)	EKRP1B2	EKRP1B2	KRP1B61	EKRP1B2 *2	KRP1B61
	Wiring adapter with 2 output signals (Compressor / Error, Fan output)	-	-	-	-	-
	Adapter for multi-tenant applications (24VAC PCB power supply interface)	DTA114A61	DTA114A61	-	DTA114A61	-
	External control adapter for outdoor unit	DTA104A61	DTA104A61	DTA104A61	DTA104A61	DTA104A61
	Installation box / Mounting plate for adapter PCBs (For units where there is no space in the switchbox)	KRP4A96	KRP4A96	-	KRP1BA101 / KRP1B100	-
	Connector for forced-off contact	Standard	Standard	Standard	Standard	Standard
	Connection to centralized control	Standard	Standard	Standard	Standard	Standard
	Electrical box with earth terminal (2 blocks)	-	-	-	KJB212A	-
	Electrical box with earth terminal (3 blocks)	-	-	-	KJB311A	-
	Electrical box with earth terminal	-	-	-	KJB411A	-
	Digital input adaptor	-	-	-	BRP7A51	-
Others	Decoration panel (obligatory for cassette units, optional for others, rear panel for FXLQ)	BYBS71D	BYBS125D	-	-	-
	Kit for mounting of decoration panel direct onto unit	EKBYBSD	EKBYBSD	-	-	-
	Panel spacer for reducing required installation height	-	-	-	-	-
	Sealing kit for 3-directional or 2-directional air discharge	-	-	-	-	-
	Decoration panel for air discharge	-	-	-	-	-
	Fresh air intake kit	-	-	-	-	-
	Air discharge adapter for round duct	KDAJ25K71	KDAJ25K140	-	KDAP25A140A	-
	Replacement long life filter	-	-	-	-	-
	Drain pump kit	Standard	Standard	-	Standard	-
	Sensor kit	-	-	-	-	-
	Noise filter (for electromagnetic use only)	-	-	KEK26-1	-	KEK26-1
L-type piping kit (for upward direction)	-	-	-	-	-	

*2 Installation box is necessary for these adapters

*3 The BYCQ140D7WIW has white insulation

Be informed that formation of dirt on white insulation is visibly stronger and that it is consequently not advised to install the BYCQ140D7WIW decoration panel in environments exposed to concentrations of dirt

*4 Not recommended because of the limitation of the functions

*5 To be able to control the BYCQ140D7GW1 the controller BRC1E is needed

*6 The BYCQ140DGW1 is not compatible with Mini VRV, Multi and Split Non-Inverter Outdoor units

*7 Option not available in combination with BYCQ140D7GW1

*8 Both parts of the fresh air intake are needed for each unit

*9 Sensing function not available

*10 Independently controllable flaps function not available

Ceiling suspended units				Wall mounted units	Floor standing units			
1-way blow			4-way blow		Concealed	Free-standing		
FXHQ 32A	FXHQ 63A	FXHQ 71~100A	FXUQ 71~100A	FXAQ 15~63	FXNQ 20~63	FXLQ 20~25	FXLQ 32~40	FXLQ 50~63
•	•	•	•	•	•	•	•	•
•*4	•*4	•*4	•*4	•*4	•*4	•*4	•*4	•*4
BRC7G53	BRC7G53	BRC7G53	BRC7C58	BRC7EB518	BRC4C65	BRC4C65	BRC4C65	BRC4C65
-	-	-	-	-	•	•	•	•
-	-	-	-	-	•	•	•	•
•	•	•	•	•	•	•	•	•
•	•	•	•	•	•	•	•	•
•	•	•	•	•	•	•	•	•
•	•	•	•	•	•	•	•	•
KRCS01-4	KRCS01-4	KRCS01-4	KRCS01-4	KRCS01-1	KRCS01-1	KRCS01-1	KRCS01-1	KRCS01-1
K.RSS	K.RSS	K.RSS	K.RSS	K.RSS	K.RSS	K.RSS	K.RSS	K.RSS
KRP4A52	KRP4A52	KRP4A52	KRP4A53 *2	KRP4A51	KRP4A51	KRP4A51	KRP4A51	KRP4A51
KRP2A62	KRP2A62	KRP2A62	-	KRP2A51	KRP2A51	KRP2A51	KRP2A51	KRP2A51
-	-	-	-	-	KRP1B61	KRP1B61	KRP1B61	KRP1B61
KRP1B54	KRP1B54	KRP1B54	-	-	-	-	-	-
-	-	-	-	DTA114A61	EKMTAC	EKMTAC	EKMTAC	EKMTAC
DTA104A62	DTA104A62	DTA104A62	-	DTA104A61	-	-	-	-
KRP1D93A	KRP1D93A	KRP1D93A	KRP1B97	KRP4A93	-	-	-	-
EKRORO4	EKRORO4	EKRORO4	EKRORO5	Standard	Standard	Standard	Standard	Standard
-	-	-	-	Standard	Standard	Standard	Standard	Standard
KJB212A	KJB212A	KJB212A	KJB212A	-	-	-	-	-
KJB311A	KJB311A	KJB311A	KJB311A	-	-	-	-	-
-	-	-	-	-	-	-	-	-
-	-	-	-	-	-	-	-	-
-	-	-	-	-	-	EKRDP25A	EKRDP40A	EKRDP63A
-	-	-	-	-	-	-	-	-
-	-	-	-	-	-	-	-	-
-	-	-	KDBHP49B140	-	-	-	-	-
-	-	-	KDBTP49B140	-	-	-	-	-
KDDQ50A140	KDDQ50A140	KDDQ50A140	-	-	-	-	-	-
-	-	-	-	-	-	-	-	-
KAFP501A56	KAFP501A80	KAFP501A160	KAFP51K160	-	-	-	-	-
KDU50P60	KDU50P140	KDU50P140	-	K-KDU572EVE	-	-	-	-
-	-	-	-	-	-	-	-	-
KEK26-1	KEK26-1	KEK26-1	-	-	-	-	-	-
KHFP5M35	KHFP5N63	KHFP5N160	-	-	-	-	-	-

*Note: blue cells contain preliminary data

Options & accessories - stylish indoor

		INDOOR UNITS							
		FTXG-LW/S	CTXS15-35K FTXS20-25K	FTXS35-50K	FTXS-G	FVXG-K	FVXS-F	FDXS-F(9)	FLXS-B(9)
Adapters and controls	Wired remote control	BRC944 (3)	BRC944 (3) (5)	BRC944 (3)	BRC944 (3)	BRC944 (3)	-	BRC1D52 BRC1E52A BRC1E52B (4)	-
	Wireless remote control	-	-	-	-	-	-	BRC4C65	-
	Simplified remote control	-	-	-	-	-	-	BRC2C51	-
	Remote control for hotel use	-	-	-	-	-	-	BRC3A61	-
	Cord for wired remote control - 3m	BRCW901A03	BRCW901A03	BRCW901A03	BRCW901A03	BRCW901A03	-	-	-
	Cord for wired remote control - 8m	BRCW901A08	BRCW901A08	BRCW901A08	BRCW901A08	BRCW901A08	-	-	-
	Wiring adapter normal open contact / normal open pulse contact	KRP413A1S (1)	KRP413A1S (1) (5)	KRP413A1S (1)	KRP413A1S (1)	KRP413A1S (1)	KRP413A1S (1)	-	KRP413A1S (1)
	Centralised control board - up to 5 rooms	KRC72 (2)	KRC72 (2)	KRC72 (2)	KRC72 (2)	KRC72 (2)	KRC72 (2)	-	KRC72 (2)
	Anti-theft protection for remote control	KKF910A4	KKF910A4	KKF910A4	KKF910A4	KKF910A4	-	-	KKF917AA4
	Interface adapter for wired remote control	-	KRP980A1	-	-	-	-	-	-
	Wiring adapter for electrical appendices	-	-	-	-	-	-	KRP4A54	-
	Remote sensor	-	-	-	-	-	-	KRC501-4	-
	Installation box for adapter PCB	-	-	-	-	-	-	KRP1BA101	-
	Electric box with earth terminal 3 blocks	-	-	-	-	-	-	KJB311A	-
	Electric box with earth terminal 2 blocks	-	-	-	-	-	-	KJB212A	-
	Interface adapter for DIII-net	KRP928A2S	KRP928A2S (5)	KRP928A2S (5)	KRP928A2S	KRP928A2S	KRP928A2S	-	KRP928A2S
Online controller	BRP069A41	BRP06942 (5)	BRP06942	BRP069A42	BRP069A42	BRP069A42	-	BRP069A42	
Modbus gateway	RTD-RA	RTD-RA (5)	RTD-RA	RTD-RA	RTD-RA	RTD-RA	RTD-NET	-	
KNX gateway	KLIC-DD	KLIC-DD (5)	KLIC-DD	KLIC-DD	KLIC-DD	KLIC-DD	KLIC-DI	KLIC-DD	
Others	Titanium apatite photocatalytic air- purification filter without frame	-	-	-	-	-	-	-	-
	Photocatalytic deodorising filter, with frame	-	-	-	-	-	-	-	KAZ917B41
	Photocatalytic deodorising filter, without frame	-	-	-	-	-	-	-	KAZ917B42
	Air purification filter, with frame	-	-	-	-	-	-	-	KAF925B41
	Installation leg	-	-	-	-	BKS028	-	-	-

(1) Wiring adapter supplied by Daikin. Time clock and other devices : to be purchased locally; (2) Wiring adapter is also required for each indoor unit; (3) Cord for wired remote control BRCW901A03 or BRCW901A08 required; (4) Standard there is no remote control delivered with this indoor unit. Wired or wireless control to be ordered separately; (5) Interface adapter KRP980A1 required.

Description	INDOOR UNITS				
	FCQG-F	FFQ-C	FDBQ-B	FBQ-D	FHQ-C
Wired remote control	BRC1D52 BRC1E52A (3) BRC1E52B (4)	BRC1D528 BRC1E52A (3) BRC1E52B(4)(9)	BRC1D52 BRC1E52A (3) BRC1E52B (4)	BRC1D52 BRC1E52A (3) BRC1E52B (4)	BRC1D52 BRC1E52A (3) BRC1E52B (4)
Intelligent touch controller	DCS601C51	DCS601C51	-	DCS601C51 (2)	-
Infrared remote control (heat pump)	BRC7FA532F (5)	BRC7EB530W BRC7F530W BRC7F530S (8-9)	-	BRC4C65	BRC7G53
Simplified remote control (with operation mode selector button)	-	BRC2E52C (12)	-	BRC2E52C (12)	-
Simplified remote control (without operation mode selector button)	-	BRC3E52C (12)	-	-	-
Residential central remote control	-	-	-	-	-
Remote control for hotel use	BRC3A61	-	-	BRC3E52C	-
Centralised remote control	DCS302C51	DCS302B51	-	DCS302C51	DCS302C51
Unified ON/OFF control	DCS301B51	DCS301B51	-	DCS301B51	DCS301B51
Schedule timer	DST301B51	DST301B51	-	DST301B51	DST301B51
Adapter for wiring (interlock for fresh air intake fan)	-	-	-	KRP1BA59	-
Adapter for external ON/OFF and monitoring/for electrical appendices	KRP1B57 KRP4A53 (1)(5)	KRP1B57 KRP4A53(6)	-	KRP4A52 (1) KRP2A51 (1)	KRP1B54 KRP4A52(1)
Interface adapter for Sky Air	-	-	-	DTA112B51	-
Installation box for adapter PCB	KRP1H98 (5)	KRP1B101 KRP1BA101	-	KRP1B(A)101	KRP1D93A
Remote sensor	KRCS01-4	KRCS01-4	-	KRCS01-4B	KRCS01-4B
Remote ON/OFF, forced OFF	-	-	-	-	EKRORO4
Electrical box with earth terminal (3 blocks)	KJB311A	-	-	-	KJB311A
Electrical box with earth terminal (2 blocks)	KJB212A	-	-	-	KJB212A
Electrical box with earth terminal	-	-	-	KJB411A	-
Adapter for wiring (hour meter)	EKRP1C11 (1)(5)	EKRP1B2	EKRP1B2	-	-
Digital input adaptor	-	BRP7A51 (1) (13)	-	BRP7A51	-
Options PCB for external electrical heater, humidifier and/or hour meter	-	-	-	EKRP1B2A (7)	-
Option PCB for group control (NIM03)	-	-	-	-	-
Mounting plate for adapter PCB	-	-	-	-	-

Notes: (1) Installation box for adapter PCB is necessary; (2) Interface adapter for Sky Air series (DTA112B51) is necessary; (3) Including following languages: English, German, French, Italian, Spanish, Dutch, Greek, Russian, Turkish, Portuguese, Polish; (4) Including following languages: English, German, Czech, Croatian, Hungarian, Romanian, Slovenian, Bulgarian, Slovak, Serbian, Albanian; (5) Option not available in combination with BYCQ140*G; (6) Installation box for adapter PCB (KRP1B101) is necessary; (7) Electrical heater, humidifier and hour meter are field supply. These parts should not be installed inside the equipment; (8) Sensing function is not available; (9) Independently controllable flaps function is not available; (10) With the infrared remote control, the individual flap control and automatic air volume control cannot be controlled; (11) Including decoration panel; (12) Including following languages: English, German, French, Dutch, Spanish, Italian, Portuguese; (13) Only possible in combination with simplified remote control BRC2/3E52C; (14) For residential use only. Cannot be used with other centralised control equipment

Notes: (1) The BYCQ140DW has white insulations. Be informed that dirt is more visible on white insulation and that it is consequently not advised to install the BYCQ140DW decoration panel in environments

Options & accessories - Ventilation & hot water

		VAM150FA	VAM250FA	VAM350FB	VAM500FB	VAM650FB
Dust filters	EN779 Medium M6	-	-	EKAFV50F6	EKAFV50F6	EKAFV80F6
	EN779 Fine F7	-	-	EKAFV50F7	EKAFV50F7	EKAFV80F7
	EN779 Fine F8	-	-	EKAFV50F8	EKAFV50F8	EKAFV80F8
Silencer	Model name	-	-	-	KDDM24B50	KDDM24B100
	Nominal pipe Diameter (mm)	-	-	-	200	200
CO ₂ sensor		-	-	BRYMA65	BRYMA65	BRYMA65
VH electrical heater for VAM		VH1B	VH2B	VH2B	VH3B	VH3B

Individual control systems	VAM-FA/FB	VKM-GB(M)
Wired remote control	BRC1E52A/B / BRC1D52	BRC1E52A/B / BRC1D52
VAM wired remote control	BRC301B61	-

Centralised control systems	VAM-FA/FB	VKM-GB(M)
Centralised remote control	DCS302C51	DCS302C51
Unified ON/OFF control	DCS301B51	DCS301B51
Schedule timer	DST301B51	DST301B51

Others	VAM150-250FA	VAM350-2000FB	VKM-GB(M)
Wiring adapter for electrical appendices (note 6)	KRP2A51	KRP2A51 (note 3)	BRP4A50A (note 4/5)
Adapter PCB for humidifier	KRP50-2	BRP4A50A (note 4/5)	BRP4A50A (note 4/5)
Adapter PCB for 3rd party heater	BRP4A50	BRP4A50A (note 4/5)	BRP4A50A (note 4/5)
Remote sensor	-	-	-

Notes

- (1) Cool/heat selector required for operation
- (2) Do not connect the system to DIII-net devices (Intelligent controller, Intelligent Manager, LonWorks interface, BACnet interface...).
- (3) Installation box KRP1BA101 needed.
- (4) Fixing plate EKMPVAM additionally needed for VAM1500-2000FB.
- (5) 3rd party heater and 3rd party humidifier cannot be combined
- (6) For external control and monitoring (ON/OFF control, operation signal, error indication)

	VH electrical heater for VAM
Supply voltage	220/250V ac 50/60 Hz. +/-10%
Output current (maximum)	19A at 40°C (ambient)
Temperature sensor	5k ohms at 25°C (table 502 IT)
Temperature control range	0 to 40°C / (0-10V 0-100%)
Run on timer	Adjustable from 1 to 2 minutes (factory set at 1.5 minutes)
Control fuse	20 X5 mm 250 m A
LED indicators	Power ON - Yellow Heater ON - Red (solid or flashing, indicating pulsed control) Airflow fault - Red
Mounting holes	98mm X 181mm centres 5 mm ø holes
Maximum ambient adjacent to terminal box	35°C (during operation)
Auto high temp. cutout	100°C Pre-set
Man. reset high temp. cutout	125°C Pre-set
Run relay	1A 120V AC or 1A 24V DC
BMS setpoint input	0-10VDC

Vh electrical heater for vam		vH1B	VH2B	VH3B	VH4B	VH4/AB	VH5B
Capacity	kW	1	1	1	1.5	2.5	2.5
Duct diameter	mm	100	150	200	250	250	350
Connectable VAM		VAM150FA	VAM250FA	VAM500FB	VAM800FB	VAM800FB	VAM1500FB
		-	VAM350FB	VAM650FB	VAM1000FB	VAM1000FB	VAM2000FB

VAM800FB	VAM1000FB	VAM1500FB	VAM2000FB	VKM50GB(M)	VKM80GB(M)	VKM100GB(M)
EKAFV80F6	EKAFV100F6	EKAFV100F6 x2	EKAFV100F6 x2	-	-	-
EKAFV80F7	EKAFV100F7	EKAFV100F7 x2	EKAFV100F7 x2	-	-	-
EKAFV80F8	EKAFV100F8	EKAFV100F8 x2	EKAFV100F8 x2	-	-	-
KDDM24B100	KDDM24B100	KDDM24B100 x2	KDDM24B100 x2	-	KDDM24B100	KDDM24B100
250	250	250	250	-	250	250
BRYMA100	BRYMA100	BRYMA200	BRYMA200	BRYMA65	BRYMA100	BRYMA200
VH4B / VH4/AB	VH4B / VH4/AB	VH5B	VH5B	-	-	-

EKEQFCB ²	EKEQDCB ²	EKEQMCB ²
BRC1E52A/B / BRC1D52	BRC1E52A/B / BRC1D52 ¹	BRC1E52A/B / BRC1D52 ¹
-	-	-

EKEQFCB ²	EKEQDCB ²	EKEQMCB ²
-	-	-
-	-	-
-	-	-

EKEQFCB ²	EKEQDCB ²	EKEQMCB ²
-	-	-
-	-	-
-	-	-
		KRCS01-1

	HXY080-125A	HXHD125A
Drain pan	EKHBDFCA2	-
Digital I/O PCB	EKRPIHBAA	-
Demand PCB - Required to connect room thermostat	EKRPIAHTA	-
Remote user interface (remocon) - Same controller as supplied with cascade unit can be mounted parallel or on other location. If 2 controllers are installed, the installer needs to select 1 master & 1 slave	EKRUAHTB	-
Back-up heater	EKBHAA6(W1/V3)	-
Wired room thermostat - Requires demand PCB EKRPIAHTA	EKRRTWA	-
Wireless room thermostat - Requires demand PCB EKRPIAHTA	EKRTR1	-
Remote sensor for room thermostat - Requires demand PCB EKRPIAHTA	EKRRTETS	-
Domestic hot water tank - standard	-	EKHTS200AC
(stacked on top of hydrobox)	-	EKHTS260AC
Domestic hot water tank - with possibility for solar connection	-	EKHWP500B
Solar collector *1	-	EKSV26P (vertical) EKSH26P (horizontal)
Pump station	-	EKSRRPS

*1 pump station is necessary for this option

Options & accessories - Ventilation (air handling units)

D-AHU Professional

Construction type		SP 65	SP 45	FP 50	FP 25
Profile	Aluminium	standard	standard	standard	standard
	Anodized aluminium	option	option	option	option
	Aluminium with thermal break	option	option	option	option
	Anodized aluminium with thermal break	option	option	option	option
Corner	Glass fibre reinforced nylon	standard	standard	standard	standard
Panel insulation	Polyurethane foam density 45 kg/m ³ thermal conductivity 0.020 W/m*K fire reaction class 1	standard	standard	standard	standard
	Mineral wool density 90 kg/m ³ thermal conductivity 0.037 W/m*K (referred to 20°C) fire reaction class 0	option	option	option	option
External sheet material	Grey Plastisol covered galvanized steel	standard	standard	standard	standard
	Pre-coated galvanized steel	option	option	option	option
	Galvanized steel	option	option	option	option
	Aluminium	option	option	option	option
	AISI 304 stainless steel	option	option	option	option
Internal sheet material	Galvanized steel	standard	standard	standard	standard
	Pre-coated galvanized steel	option	option	option	option
	Grey Plastisol covered galvanized steel	option	option	option	option
	Aluminium	option	option	option	option
	AISI 304 stainless steel	option	option	option	option
Base frame	Aluminium	standard (from size 1 to size 17)	standard (from size 1 to size 17)	standard (from size 1 to size 17)	standard (from size 1 to size 17)
	Galvanized steel	standard (from size 18 to size 27)	standard (from size 18 to size 27)	standard (from size 18 to size 27)	standard (from size 18 to size 27)
Handle	Glass fibre reinforced nylon	standard	standard	standard	standard
Type	Compression type	standard	standard	standard	standard
	Hinge function type (possibility to remove door)	option	option	option	option

D-AHU Easy

Construction type		DS 50	DS 25
Profile	Aluminium	Standard	Standard
Corner	Glass fibre reinforced nylon	Standard	Standard
Panel insulation	Polyurethane foam thermal conductivity 0.024 W/m*K	Standard (density 45 kg/m ³)	standard (density 47 kg/m ³)
External sheet material	Pre-coated galvanized steel (RAL 9002)	Standard	Standard
Internal sheet material	Galvanized steel	Standard	Standard
Base frame	Aluminium	Standard	Standard
Handle	Glass fibre reinforced nylon	Standard	Standard
Type	Compression type	Standard	Standard

		DCM601A51	DMS504B51	DMS502A51
			LonWorks Interface	BACnet Interface
iTM plus adapter		DCM601A52		
iTM ppd software		DCM002A51		
iTM energy navigator software		DCM008A51		
iTM BACnet option		DCM009A51		
WAGO I/O	Modbus communication unit	WGDCMCPLR		
	DC24V power supply unit:	787-712		
	DC24V power supply unit:	750-613		
	Connector:	750-960		
	Terminator module:	750-600		
	Di module:	750-400, 750-432		
	Do module:	750-513/000-001		
	Ai module:	750-454, 750-479		
	Thermistor module:	750-461/020-000		
Interface adapter for connection to RA units			KRP928A2S	KRP928A2S
Interface adapter for connection to R-407C/R-22 Sky Air units			DTA102A52	DTA102A52
Interface adapter for connection to R-410A Sky Air units			DTA112B51	DTA112B51
DIII board				DAM411B51
Digital input/output				DAM412B51

Over 30 years of VRV History



R-22

The original **VRV** air conditioning system **developed by Daikin Industries Ltd.** in 1982 is **introduced into Europe** in VRV standard format. VRV D series can supply conditioned air from up to 6 indoor units connected to a single outdoor unit.

1987

1991

A further step forward is taken in 1991 with the introduction of the **VRV heat recovery** system, offering simultaneous cooling and heating from different indoor units on the same refrigeration circuit.



R-407C

In anticipation of phase out dates for all CFC based equipment, Daikin Europe launched a VRV interter series with **R-407C**. As many as 16 indoor units can be connected to 1 single outdoor unit.

1994

1998

Consistent high quality and efficiency lead to the widespread acceptance of the VRV concept and Daikin becomes the first Japanese air conditioning manufacturer to be awarded the **ISO9001** certification.



The introduction of the **VRVII-S** series extends the VRV operating scope into the **light commercial** sectors. Available in 4, 5 and 6HP capacities, the system is designed for installation in up to 9 rooms.



2003

2004

Daikin introduces the VRVII, the **world's first R-410A** operated variable refrigerant flow system. Available in cooling only, heat pump and heat recovery versions. No less than **40 indoor units** in heat recovery as well as heat pump format can be connected to a single refrigerant circuit.

2005

Daikin extends the operational scope of its acclaimed VRVII inverter driven dx air conditioning system, with a new **water cooled** version, **VRV-WII**. Available in both **heat pump** and **heat recovery** versions.



R-410A



Daikin introduces a new heat pump range optimised for heating (VRVIII-C). This new range has an **extended operation range down to -25°C** and has a greatly improved COP in low ambient temperatures, with the newly developed 2-stage compressor system.



Daikin extends the VRVIII range with the water cooled VRV-WIII. A **geothermal** version is also available now.

This system uses geothermal heat as a **renewable energy** source and can operate down to -10°C in heating mode.

Daikin launches the **'total solution'** concept by integrating **hot water production** and **Biddle air curtains** in the VRV system. The range of indoor units is also expanded by offering the possibility to connect residential indoor units as **Daikin Emura or Nexura** to the VRV system. 2011 also confirms VRV as established solution in the market reaching **400,000 outdoor units** and **2.2 million indoor units sold**.



2006-2007

2008

2009

2010

2011

2012



Daikin announces the third generation of its much acclaimed VRV range with the extensively re-engineered **VRVIII**. Available in heat recovery, heat pump and cooling versions, VRVIII incorporates all the best features of earlier VRV systems. However, it also possesses a considerable number of new design, installation and maintenance refinements such as **automatic charging and testing**.

Up to **64 indoor units** can be connected to one system.

Daikin extends its VRV range with the innovative replacement VRV – a highly cost effective **replacement for VRV** systems still operating on the banned **R-22** refrigerant. This cost effective upgrade is possible because VRVIII-Q outdoor units can be installed using existing piping and in some cases existing indoor units.

The fourth generation of VRV is launched. The unit sets new standards in the industry with **28% better seasonal efficiency** and continuous heating on heat pumps.





Research & development

Creating value through innovative technologies

R&D is essential for the creation of products that enrich people's lives. As symbolised by the VRV, Daikin is at the forefront of innovative technology and the development of market leading products: the result of our advanced R&D system.

Superior products from multi-part development approach

To create more advanced functions with added value, Daikin has set up the 'Environmental Technology Research Laboratory' and the 'Solution Product Development Center'. Working with the Product Development Group, the three divisions cooperate closely to ascertain and meet the customers' needs and to enable commercialisation of products incorporating advanced technology.

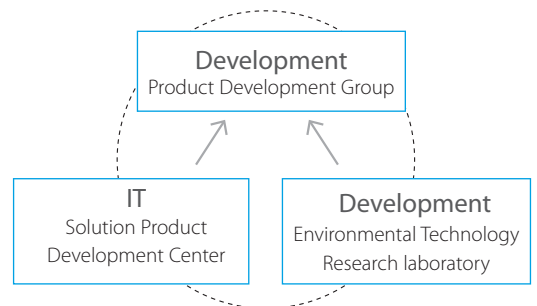

Intensive research on environmental impact

The diverse needs in different countries encountered during the accelerating globalisation of our air conditioning business have presented us with increased research challenges particularly in terms of environmental impact. To promote energy savings in and to lower the environmental impact of our air conditioners, we have developed technologies based on fundamental research into motor inverters and many other areas.

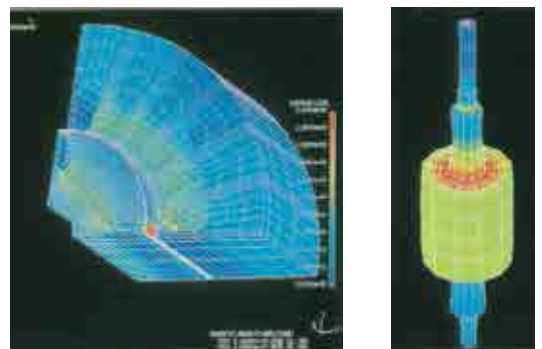

IT and air conditioners: the obvious solution

With advances in computerisation and networking, we have integrated IT into our air conditioners including communication technology and advanced software for total control. Our new control systems enable users to develop comfortable environments with superior energy savings by networking air conditioners to enable them to exchange information with each other and with our service centres.





Environment

Five-year results for the environmental action plan 2010

Under the five-year FUSION 10 strategic management plan, which targeted fiscal year 2010, the Daikin Group strove to develop and promote the use of environmentally conscious products and services on a basic policy of actively contributing to solving global environmental problems and expanding business. Our environmental measures were conducted under our Environmental Action Plan 2010.

Reducing Environmental Impact from products

Five year result

Promote and expand the use of environmentally conscious products to meet the particular needs of each world region.

We have developed and provided air conditioner products and services that meet the environmental needs of each world region in terms of weather, culture, and economy.

Five years target

Promote the use of environmentally conscious products, particularly in rapidly growing developing countries

Daikin will continue to provide air conditioning products and services that meet the environmental needs of each world region. Particularly in developing countries, which are growing fast but where increasing environmental impact is a problem, Daikin will provide products and technologies that contribute to economic progress yet still protect the environment.

Europe

Fifteen-fold increase in heat-pump hot water and space heating

We have successfully promoted the use of the Daikin Altherma hot water and space heating system in the process contributing to the reduction of 210,000 tons of CO₂ emissions.

Proliferating results

Units of Daikin ALtherma sold in Europe

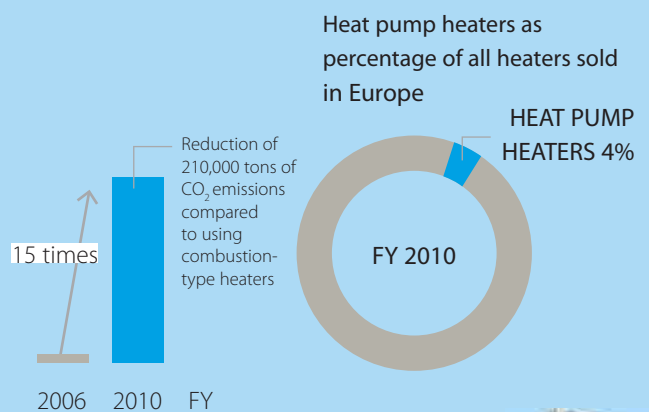



Literature overview

Daikin has a wide portfolio of commercial catalogues in order to supply you with information or help you to sell our products to your customers.

Literature for professional network	258
Literature for your customers	259

Commercial market - literature overview

for professional network

Solution guides:



Hotel Solutions
Clear installer benefits why to choose Daikin for a hotel

15-217

Reference books:



Product profiles:



VRV IV range
Detailed VRV IV standards and technologies benefits. Main features and specs of VRV IV product range

15-206



Rooftop UAYTQ-CY1
Detailed rooftop benefits incl. UAYTQ-CY1, ECONO-AY1

15-120

Focus topics:



Replacement Technology
Clear installer benefits of VRV replacement technology

15-214

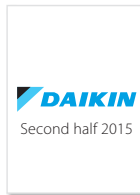

Technical cooling
Clear installer benefits why to choose Daikin for technical cooling

15-140

Product flyers:



Wired Remote Control
Detailed info on BRC1E52A/B remote control

15-306



KNX Interface
Detailed info on KLIC-DI and KLIC-DD interfaces

15-310



DIII-net modbus gateway
Detailed info on EKMBDXA modbus interface

15-312



VAM electrical heater
Detailed info on electrical heater for VAM

15-311

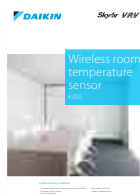

Wireless temperature sensor
Detailed info on wireless sensor K.RSS

15-309

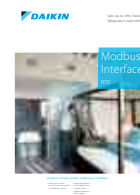

RTD modbus interface
Detailed info on RTD controls and applications

15-308

Product catalogues:



Sky Air Catalogue
Detailed technical information & benefits on Sky Air/Ventilation/Biddle Air Curtain/Control systems/AHU

15-114



VRV Catalogue
Detailed technical information & benefits of the VRV total solution

15-200



Ventilation Catalogue
Detailed info on Ventilation products

15-203

Product portfolios:



Sky Air product portfolio
Overview of Sky air product range

15-121



VRV product portfolio
Overview of VRV total solution product range

15-201

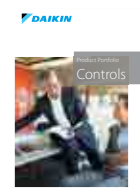

Controls systems portfolio
Overview of all Daikin control systems

15-301

for your customers



Commercial Solutions

Daikin offers solutions for commercial applications

15-100

Reference catalogue
Daikin commercial and industrial references

14-213

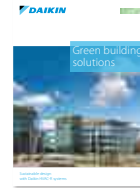

Green Building Solutions

Clear building owner/investor benefits why to choose Daikin for a green building, with emphasis on BREEAM

15-216



Hotel Solutions

Clear building owner/investor benefits why to choose Daikin for a hotel

15-218

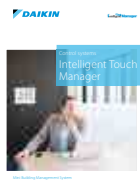

Intelligent Touch Manager

Detailed benefits of Intelligent Touch Manager

15-302

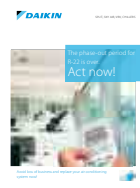

Replacement technology

Clear building owner/investor benefits of replacement technology

15-215



Sky Air product leaflets

Single page leaflet with the main benefits and technical specifications of each individual Sky Air unit. Ideal for quotations



VRV product leaflets

Single page leaflet with the main benefits and technical specifications of each individual VRV unit. Ideal for quotations



Cassette mini catalogue

Giving overview of our cassette unit product solutions (incl. Round flow cassette FCQ(H)G-F/FXFQ-A, Fully flat cassette FFQ-C/FXZQ-A, FUQ-C/FXUQ-A, ACQ-C)

15-110



Concealed ceiling unit mini catalogue

Catalogue giving overview of our concealed ceiling unit product solutions (incl. FDXS-F(9), FBQ-D, FDQ-C, FDQ-B, FXDQ-M9, FXDQ-A, FXSQ-A, FXMQ-P7, FXMQ-MA)

15-106



Ceiling suspended, wall mounted, floor standing units mini catalogue

Catalogue giving overview of our Ceiling suspended, wall mounted and floor standing product solutions. (incl. FXHQ-A, FHQ-C, FXAQ-A, FAQ-C, FXNQ-A, FNQ-A, FXLQ-P, FVQ-C)

15-101



Technical documentation:

Download all technical documentation such as engineering databooks, selection software, installation and operation manuals and service manuals directly from our extranet: extranet.daikineurope.com

360°
efficiency

installation
efficiency

design
efficiency

operational
efficiency



FAST + **QUICK** + **MORE** + **MAX**
design installation free heat comfort

Our new VRV IV heat recovery systems sets pioneering standards in all-round climate comfort efficiency.

Total design simplicity, rapid installation, full flexibility with absolute efficiency and comfort. Find out about all revolutionary changes on www.daikineurope.com/vrviv

Daikin Europe N.V. Naamloze Venootschap Zandvoordestraat 300 · 8400 Oostende · Belgium · www.daikin.eu · BE 0412 120 336 · RPR Oostende (Responsible Editor)

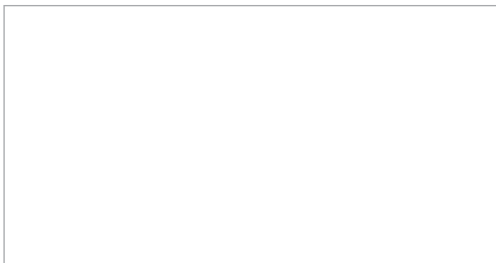

ECPEN15-200A 500 · 03/15



Daikin Europe N.V. participates in the Eurovent Certification programme for Liquid Chilling Packages (LCP), Air handling units (AHU), Fan coil units (FCU) and variable refrigerant flow systems (VRF) Check ongoing validity of certificate online: www.eurovent-certification.com or using: www.certiflash.com

The present publication is drawn up by way of information only and does not constitute an offer binding upon Daikin Europe N.V. Daikin Europe N.V. has compiled the content of this publication to the best of its knowledge. No express or implied warranty is given for the completeness, accuracy, reliability or fitness for particular purpose of its content and the products and services presented therein. Specifications are subject to change without prior notice. Daikin Europe N.V. explicitly rejects any liability for any direct or indirect damage, in the broadest sense, arising from or related to the use and/or interpretation of this publication. All content is copyrighted by Daikin Europe N.V.

The present publication supersedes ECPEN14-115. Printed on non-chlorinated paper. Prepared by Platzer Kommunikation, Germany.